

This operation manual is intended for users with basic knowledge of electricity and electric devices.

* LSLV- M100 is the official name for the M100 series inverters.

Thank you for purchasing LS ELECTRIC inverter.

Safety Information

Read and follow all safety instructions in this manual precisely to avoid unsafe operating conditions, property damage, personal injury, or death.

Safety symbols in this manual

Danger

Indicates an imminently hazardous situation which, if not avoided, will result in severe injury or death.

Warning

Indicates a potentially hazardous situation which, if not avoided, could result in injury or death.

Caution

Indicates a potentially hazardous situation that, if not avoided, could result in minor injury or property damage.

Safety information

Danger

- Do not open the cover of the equipment while it is on or operating. Likewise, do not operate the inverter while the cover is open. Exposure of high voltage terminals or charging area to the external environment may result in an electric shock. Do not remove any covers or touch the internal circuit boards (PCBs) or electrical contacts on the product when the power is on or during operation. Doing so may result in serious injury, death, or serious property damage.
- Do not open the cover of the equipment even when the power supply to the inverter has been turned off unless it is necessary for maintenance or regular inspection. Opening the cover may result in an electric shock even when the power supply is off.
- The equipment may hold charge long after the power supply has been turned off. Use a multi-meter to make sure that there is no voltage before working on the inverter, motor or motor cable.

 Warning

- This equipment must be grounded for safe and proper operation.
- Do not supply power to a faulty inverter. If you find that the inverter is faulty, disconnect the power supply and have the inverter professionally repaired.
- The inverter becomes hot during operation. Avoid touching the inverter until it has cooled to avoid burns.
- Do not allow foreign objects, such as screws, metal chips, debris, water, or oil to get inside the inverter. Allowing foreign objects inside the inverter may cause the inverter to malfunction or result in a fire.
- Do not operate the inverter with wet hands. Doing so may result in electric shock.
- Check the protection degree of circuits and equipments used in the inverter degree of circuit protection and the degree of equipment protection.

The following connection terminals and components are electrical protection class 0 devices. The circuit is protected by the essential insulation and electric shock may occur if the insulation is done improperly. The same protection measures for electric cables must be taken when the using or installing the following components, or when you connect a cable to the following terminals or components.

- Multi-function terminals: P1–P3, P4 (Advanced I/O), P5 (Advanced I/O), CM
 - Analog terminal inputs and outputs: VR, V1, I2 (Advanced I/O), AO, CM
 - Other terminal block connectors: Q1 (Standard I/O), EG (Standard I/O), 24, A1, B1, C1, A2 (Advanced I/O), C2 (Advanced I/O)
 - Cooling fan
- This inverter is a protection class 1 product.

 Caution

- Do not modify the interior workings of the inverter. Doing so will void the warranty.
- The inverter is designed for 3-phase motor operation. Do not use the inverter to operate a single phase motor.
- Do not place heavy objects on top of electric cables. Doing so may damage the cable and result in an electric shock.

Note

Maximum allowed prospective short-circuit current at the input power connection is defined in IEC 60439-1 as 100 kA. Depending on the selected MCCB, the LSLV-M100 Series is suitable for use in circuits capable of delivering a maximum of 100 kA RMS symmetrical amperes at the drive's maximum rated voltage. The following table shows the recommended MCCB for RMS symmetrical amperes.

Remarque

Le courant maximum de court-circuit présumé autorisé au connecteur d'alimentation électrique est défini dans la norme IEC 60439-1 comme égal à 100 kA. Selon le MCCB sélectionné, la série LSLV-M100 peut être utilisée sur des circuits pouvant fournir un courant RMS symétrique de 100 kA maximum en ampères à la tension nominale maximale du variateur. Le tableau suivant indique le MCCB recommandé selon le courant RMS symétrique en ampères.

| Working Voltage | UTE100(E/N) | UTS150(N/H/L) | ABS33c | ABS53c | ABS63c | ABS103c |
|-----------------|-------------|---------------|--------|--------|--------|---------|
| 240V(50/60Hz) | 50/65 kA | 65/100/150 kA | 30 kA | 35 kA | 35 kA | 85 kA |

Quick Reference Table

The following table contains situations frequently encountered by users while working with inverters. Refer to the typical and practical situations in the table to quickly and easily locate answers to your questions.

| Situation | Reference |
|---------------------------------------------------------------------------------------------|--------------------------------------------------------------------------------------------|
| I want to configure the inverter to start operating as soon as the power source is applied. | <u>p.84</u> |
| I want to configure the motor's parameters. | <u>p.193</u> |
| Something seems to be wrong with the inverter or the motor. | <u>p.217</u> |
| What are the recommended wiring lengths? | <u>p.23</u> |
| The motor is too noisy. | <u>p.130</u> |
| I want to apply PID control on my system. | <u>p.121</u> |
| What are the factory default settings for multi-function terminals? | <u>p. 201,</u> <u>p. 205</u> |
| I want to review recent fault trip and warning histories. | <u>p.156</u> |
| I want to change the inverter's operation frequency using a potentiometer. | <u>p.68,</u> <u>p.69</u> <u>p.71</u> |
| I want to install a frequency meter using an analog terminal. | <u>p.142</u> |
| I want to monitor the supply current to motor. | <u>p.58,</u> <u>p.151</u> |
| I want to operate the inverter using a multi-step speed configuration. | <u>p. 78</u> |
| The motor runs too hot. | <u>p.159</u> |
| The inverter is too hot. | <u>p.161</u> |
| The cooling fan does not work. | <u>p.150</u> |
| I want to change the items that are monitored on the keypad. | <u>p.232</u> |
| I want to operate the inverter using a multi-step speed configuration. | <u>p.151</u> |

Table of Contents

| | | |
|----------|--------------------------------------------------------------------------------|-----------|
| 1 | Preparing the Installation..... | 1 |
| 1.1 | Product Identification | 1 |
| 1.2 | Part Names..... | 3 |
| 1.3 | Installation Considerations | 6 |
| 1.4 | Selecting and Preparing a Site for Installation..... | 7 |
| 1.5 | Cable Selection | 11 |
| 2 | Installing the Inverter | 13 |
| 2.1 | Mounting the Inverter..... | 15 |
| 2.2 | Cable Wiring | 18 |
| 2.3 | Post-Installation Checklist..... | 34 |
| 2.4 | Test Run | 36 |
| 3 | Learning to Perform Basic Operations..... | 39 |
| 3.1 | About the Keypad..... | 39 |
| 3.1.1 | About the Display | 40 |
| 3.1.2 | Operation Keys..... | 41 |
| 3.1.3 | Control Menu | 42 |
| 3.2 | Learning to Use the Keypad..... | 43 |
| 3.2.1 | Group Selection | 43 |
| 3.2.2 | Code Selection | 45 |
| 3.2.3 | Navigating Directly to Different Codes | 46 |
| 3.2.4 | Switching to a Different Code | 47 |
| 3.2.5 | Setting Parameter Values | 48 |
| 3.3 | Actual Application Examples..... | 49 |
| 3.3.1 | Acceleration Time Configuration..... | 49 |
| 3.3.2 | Frequency Reference Configuration | 50 |
| 3.3.3 | Frequency Setting | 51 |
| 3.3.4 | Initializing All Parameters | 52 |
| 3.3.5 | Frequency Setting (Keypad) and Operation (via Terminal Input)..... | 53 |
| 3.3.6 | Frequency Setting (External Potentiometer) and Operation (Terminal Input)..... | 54 |

| | | |
|----------|----------------------------------------------------------------------------------------|-----------|
| 3.3.7 | Frequency Setting (Built-in Potentiometer) and Operation (Keypad)..... | 56 |
| 3.4 | Monitoring the Operation..... | 58 |
| 3.4.1 | Output Current Monitoring..... | 58 |
| 3.4.2 | Fault Trip Monitoring..... | 59 |
| 4 | Control Block Diagram | 61 |
| 4.1 | Setting Frequency | 62 |
| 4.2 | Setting Run Command..... | 64 |
| 4.3 | Controlling Acc/Dec and V/F Voltage..... | 65 |
| 5 | Learning Basic Features | 67 |
| 5.1 | Setting Frequency Reference | 67 |
| 5.1.1 | Keypad as the Source (KeyPad-1 setting)..... | 68 |
| 5.1.2 | Keypad as the Source (KeyPad-2 setting)..... | 68 |
| 5.1.3 | Built-in Volume input (V0) 0 – 5 [V] as the Source..... | 68 |
| 5.1.4 | V1 Terminal as the Source | 69 |
| 5.1.5 | Input Current (Terminal I2) as the Source..... | 71 |
| 5.1.6 | Input Voltage (Terminal I2) as the Source..... | 72 |
| 5.1.7 | Built-in Volume (V0) and I2 Terminal..... | 72 |
| 5.1.8 | Frequency Reference Setting via Built-in Volume (V0) and I2 Terminal..... | 73 |
| 5.1.9 | Frequency Reference Setting via Built-in Volume (V0) and V1 Terminal | 74 |
| 5.1.10 | Frequency Reference Setting via V1 Terminal and I2 Terminal..... | 75 |
| 5.1.11 | Frequency Reference Setting via RS-485 Communication..... | 76 |
| 5.1.12 | Frequency Reference Setting via Digital Volume (Up-Down)..... | 76 |
| 5.2 | Holding Analog Command Frequency..... | 77 |
| 5.3 | Setting Multi-step Frequency | 78 |
| 5.4 | Command Source Configuration..... | 80 |
| 5.4.1 | The Keypad as a Command Input Device | 80 |
| 5.4.2 | Terminal Block as a Command Input Device (Fwd/Rev Run Commands) | 81 |
| 5.4.3 | Terminal Block as a Command Input Device (Run and Rotation Direction Commands)..... | 82 |
| 5.4.4 | RS-485 Communication as a Command Input Device..... | 83 |

| | | |
|----------|--------------------------------------------------------------------|------------|
| 5.5 | Forward or Reverse Run Prevention | 84 |
| 5.6 | Power-on Run..... | 84 |
| 5.7 | Reset and Restart..... | 85 |
| 5.8 | Setting Acceleration and Deceleration Times | 86 |
| 5.8.1 | Acc/Dec Time Based on Maximum Frequency | 86 |
| 5.8.2 | Acc/Dec Time Based on Operation Frequency..... | 87 |
| 5.8.3 | Multi-step Acc/Dec Time Configuration..... | 88 |
| 5.9 | Acc/Dec Pattern Configuration | 91 |
| 5.10 | Stopping the Acc/Dec Operation | 94 |
| 5.11 | V/F(Voltage/Frequency) Control..... | 95 |
| 5.11.1 | Linear V/F Pattern Operation..... | 95 |
| 5.11.2 | Square Reduction V/F pattern Operation..... | 96 |
| 5.11.3 | User V/F Pattern Operation..... | 96 |
| 5.11.4 | Output Voltage Setting..... | 97 |
| 5.12 | Torque Boost..... | 98 |
| 5.12.1 | Manual Torque Boost..... | 98 |
| 5.12.2 | Auto Torque Boost..... | 100 |
| 5.13 | Stop Mode Setting..... | 101 |
| 5.13.1 | Deceleration Stop | 101 |
| 5.13.2 | Stop After DC Braking..... | 101 |
| 5.13.3 | Free Run Stop | 102 |
| 5.14 | Frequency Limit | 103 |
| 5.14.1 | Frequency Limit Using Maximum Frequency and Start Frequency | 103 |
| 5.14.2 | Frequency Limit Using Upper and Lower Limit Frequency Values | 103 |
| 5.14.3 | Frequency Jump..... | 104 |
| 5.15 | Cooling Fan Control | 106 |
| 6 | Learning Advanced Features..... | 107 |
| 6.1 | DC Braking | 107 |
| 6.1.1 | Stop After DC Braking..... | 107 |
| 6.1.2 | Start After DC Braking..... | 108 |
| 6.1.3 | DC Braking During Stop | 109 |

| | | |
|----------|-------------------------------------------------------------------|------------|
| 6.2 | Jog operation..... | 110 |
| 6.2.1 | Jog Operation 1-Forward Jog by Multi-function Terminal..... | 110 |
| 6.2.2 | Jog Operation 2-Fwd/Rev Jog by Multi-function Terminal | 111 |
| 6.3 | Up-down Operation | 112 |
| 6.4 | 3-Wire Operation..... | 116 |
| 6.5 | Dwell Operation | 117 |
| 6.6 | Slip Compensation Operation..... | 119 |
| 6.7 | Simple Sensorless Control..... | 121 |
| 6.8 | PID Control | 121 |
| 6.8.1 | PID Basic Control..... | 122 |
| 6.9 | Energy Saving Operation..... | 126 |
| 6.10 | Speed Search Operation | 127 |
| 6.11 | Auto Restart Settings..... | 129 |
| 6.12 | Operational Noise Settings (carrier frequency settings)..... | 130 |
| 6.13 | 2nd Motor Operation..... | 131 |
| 6.14 | Frequency Setting and 2 nd Operation Mode Setting..... | 132 |
| 6.15 | Input Voltage Setting..... | 135 |
| 6.16 | Parameter Initialization | 136 |
| 6.17 | Parameter Lock..... | 138 |
| 6.18 | Voltage Trip Prevention During Deceleration..... | 139 |
| 6.19 | Brake Control | 140 |
| 6.20 | Analog Output..... | 142 |
| 6.21 | Digital Output..... | 143 |
| 6.21.1 | Multi-function Relay Output Terminal Settings | 143 |
| 6.22 | Draw Operation..... | 148 |
| 6.23 | Operation Mode Setting When Cooling Fan is Abnormal | 150 |
| 6.24 | Operation State Monitor..... | 151 |
| 6.25 | I/O Terminal Block State Monitor | 154 |
| 6.26 | Fault State Monitor..... | 156 |
| 7 | Learning Protection Features | 159 |
| 7.1 | Motor Protection | 159 |

| | | |
|----------|-------------------------------------------------------|------------|
| 7.1.1 | Electronic Thermal Motor Overheating Prevention (ETH) | 159 |
| 7.1.2 | Overload Early Warning and Trip | 161 |
| 7.1.3 | Stall Prevention | 162 |
| 7.2 | Inverter and Sequence Protection | 163 |
| 7.2.1 | Output Open-phase Protection | 163 |
| 7.2.2 | External Trip Signal | 164 |
| 7.2.3 | Inverter Overload Protection | 165 |
| 7.2.4 | Speed Command Loss | 166 |
| 7.2.5 | Dynamic Braking (DB) Resistor Configuration | 168 |
| 7.2.6 | Initial charging circuit trip(ROT) | 170 |
| 8 | RS-485 Communication Features | 171 |
| 8.1 | Communication Standards | 171 |
| 8.2 | Communication System Configuration | 172 |
| 8.2.1 | Communication Line Connection | 173 |
| 8.2.2 | Setting Communication Parameters | 173 |
| 8.2.3 | Setting Operation Command and Frequency | 175 |
| 8.2.4 | Command Loss Protective Operation | 175 |
| 8.2.5 | Parameter Group for Data Transmission | 176 |
| 8.3 | Communication Protocol | 176 |
| 8.3.1 | LS INV 485 Protocol | 176 |
| 8.3.2 | Modbus-RTU Protocol | 183 |
| 8.4 | Compatible Common Area Parameter | 186 |
| 9 | Table of Functions | 189 |
| 9.1 | Operation Group | 189 |
| 9.2 | Drive Group (PAR → dr) | 191 |
| 9.3 | Basic Function group (PAR→bA) | 193 |
| 9.4 | Expanded Function group (PAR→Ad) | 197 |
| 9.5 | Control Function group (PAR→Cn) | 200 |
| 9.6 | Input Terminal Block Function group (PAR→In) | 201 |
| 9.7 | Output Terminal Block Function group (PAR→OU) | 205 |
| 9.8 | Communication Function group (PAR→CM) | 207 |

| | | |
|-----------|-------------------------------------------|------------|
| 9.9 | Application Function group (PAR→AP) | 209 |
| 9.10 | Protection Function group (PAR→Pr) | 211 |
| 9.11 | 2nd Motor Function group (PAR→M2) | 214 |
| 9.12 | Config Mode group (PAR→CF) | 215 |
| 10 | Troubleshooting | 217 |
| 10.1 | Trips | 217 |
| 10.1.1 | Fault Trips | 218 |
| 10.2 | Troubleshooting Fault Trips | 220 |
| 10.3 | Troubleshooting Other Faults | 222 |
| 11 | Maintenance | 229 |
| 11.1 | Regular Inspection Lists | 229 |
| 11.1.1 | Daily Inspections | 229 |
| 11.1.2 | Annual Inspections | 230 |
| 11.1.3 | Bi-annual Inspections | 232 |
| 11.2 | Storage and Disposal | 232 |
| 11.2.1 | Storage | 232 |
| 11.2.2 | Disposal | 233 |
| 12 | Technical Specification | 235 |
| 12.1 | Input and Output Specification | 235 |
| 12.2 | Product Specification Details | 236 |
| 12.3 | External Dimensions (IP 20 Type) | 238 |
| 12.4 | Peripheral Devices | 240 |
| 12.5 | Fuse and Reactor Specifications | 240 |
| 12.6 | Terminal Screw Specification | 241 |
| 12.7 | Braking Resistor Specification | 242 |
| 12.8 | Continuous Rated Current Derating | 243 |
| 12.9 | Remote Keypad Option | 246 |
| | Product Warranty | 248 |
| | Index | 252 |

1 Preparing the Installation

This chapter provides details on product identification, part names, correct installation and cable specifications. To install the inverter correctly and safely, carefully read and follow the instructions.

1.1 Product Identification

The M100 Inverter is manufactured in a range of product groups based on drive capacity and power source specifications. Product name and specifications are detailed on the rating plate. The illustration on the next page shows the location of the rating plate. Check the rating plate before installing the product and make sure that the product meets your requirements. For more detailed product specifications, refer to [12.1 Input and Output Specification](#) on page [235](#).

Note

Check the product name, open the packaging, and then confirm that the product is free from defects. Contact your supplier if you have any issues or questions about your product.

LSLV0022M100-1E0FNS

INPUT 200-240V 1 Phase 50/60Hz
10.0A

OUTPUT 0-inputV 1 Phase 0.01-400Hz
3.8kVA

Ser. No 55025310146
Inspected by D. K. YU
KCC-REM-LSR-XXXXXXXX

LSLV 0022 M100 - 1E0FNS

Motor capacity _____

0001 - 0.1kW
0002 - 0.2kW
0004 - 0.4kW
0008 - 0.75kW
0015 - 1.5kW
0022 - 2.2kW

Series name _____

Input voltage _____

1 - Single phase 200V-240V

Keypad _____

E - LED Keypad

UL Type _____

O - UL Open Type

EMC filter _____

F - Built-in EMC filter(C2)

Reactor _____

N - Non-Reactor

I/O _____

S - Standard
A - Advanced

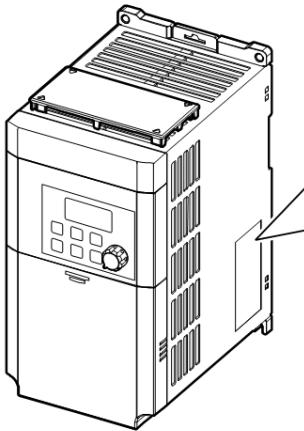

1.2 Part Names

The illustration below displays part names. Details may vary between product groups.

0.1~0.2 kW (Single Phase)

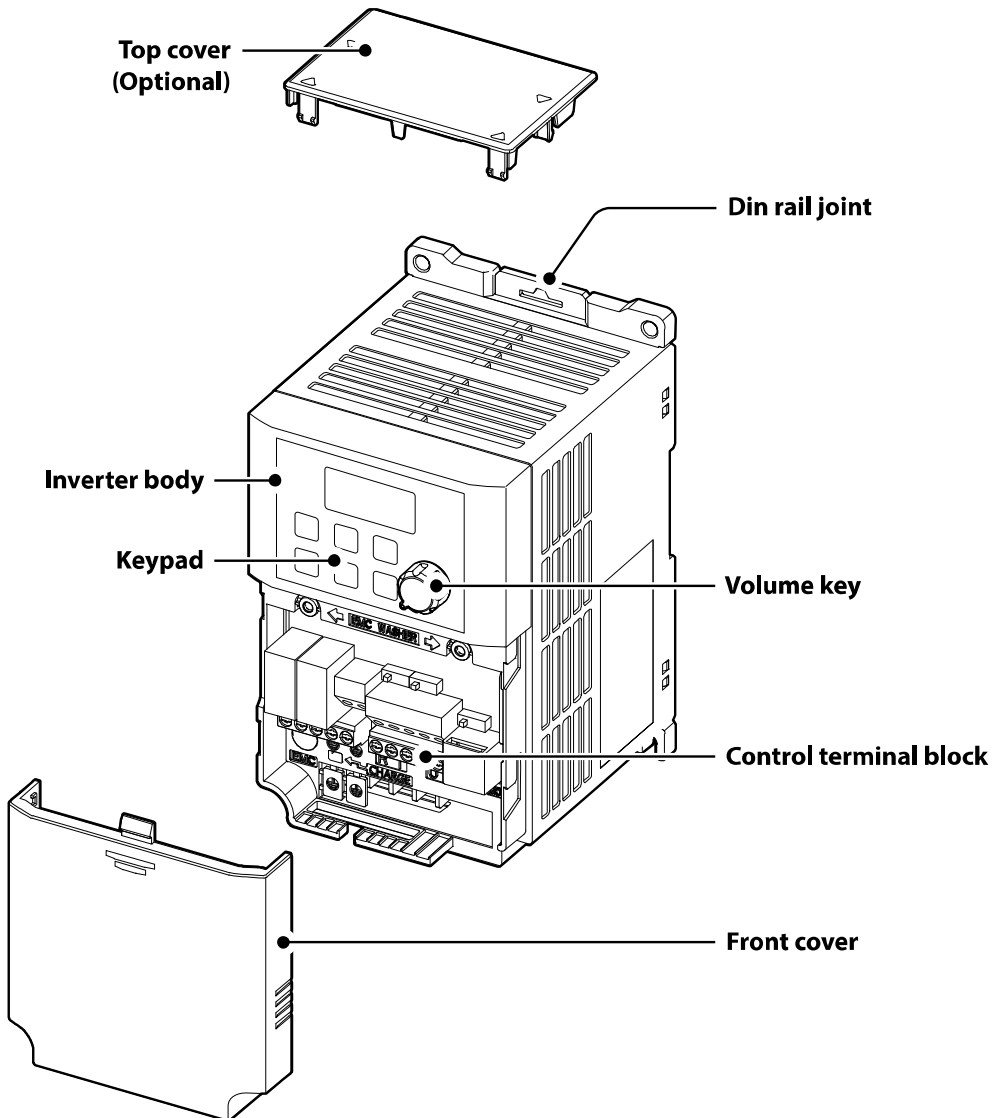

0.4~0.75 kW (Single Phase)

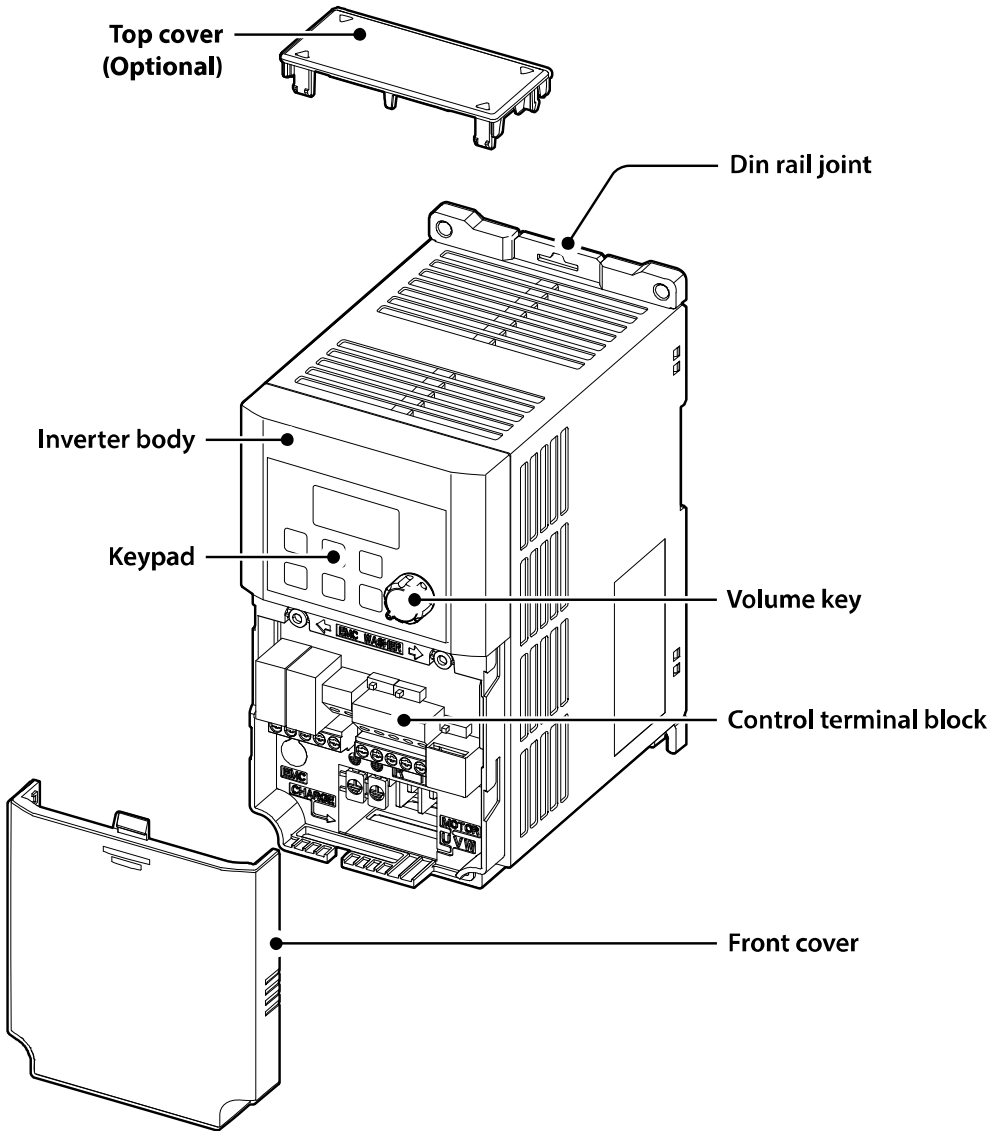

1.5~2.2 kW (Single Phase)

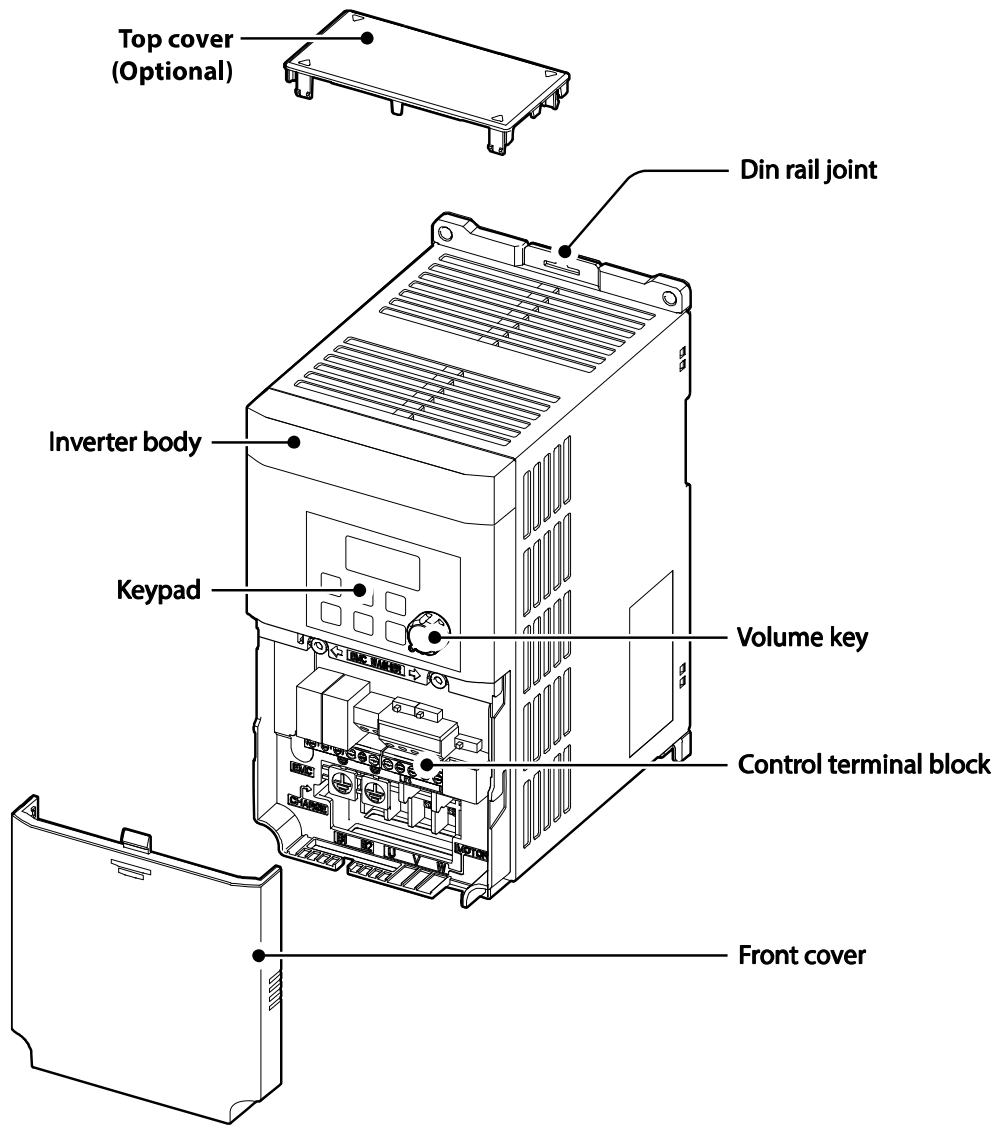

1.3 Installation Considerations

Inverters are composed of various precision, electronic devices, and therefore the installation environment can significantly impact the lifespan and reliability of the product. The table below details the ideal operation and installation conditions for the inverter.

| Items | Description |
|-----------------------------------|--------------------------------------------------------------------------------------|
| Ambient Temperature ¹⁾ | 14–122°F (-10–50 °C) |
| Ambient Humidity | 95% relative humidity (no condensation) |
| Storage Temperature | - 4–149°F (-20–65 °C) |
| Environmental Factors | An environment free from corrosive or flammable gases, oil residue or dust |
| Altitude/Vibration | Lower than 3,280 ft (1,000 m) above sea level/less than 1G (9.8 m/sec ²) |
| Air Pressure | 70~106 kPa |

1) The ambient temperature is the temperature measured at a point 2" (5 cm) from the surface of the inverter.

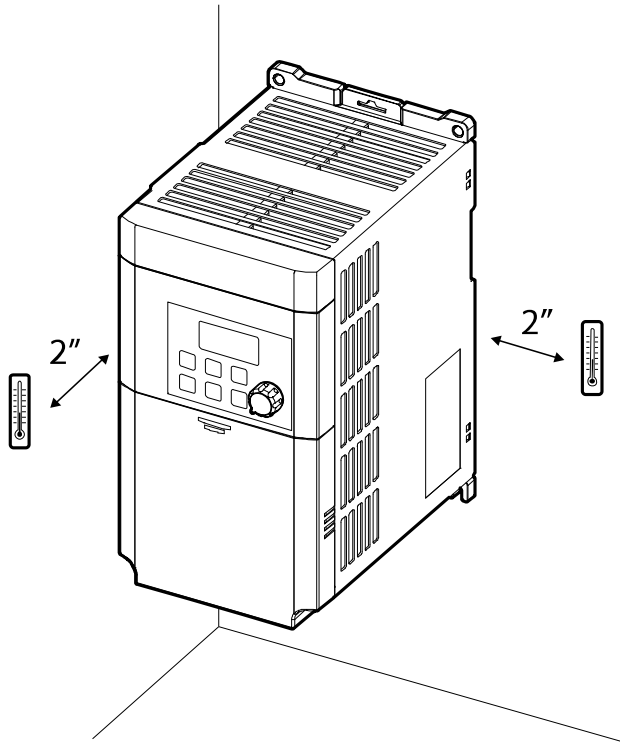

⚠ Caution

Do not allow the ambient temperature to exceed the allowable range while operating the inverter.

1.4 Selecting and Preparing a Site for Installation

When selecting an installation location consider the following points:

- The inverter must be installed on a wall that can support the inverter's weight.
- The location must be free from vibration. Vibration can adversely affect the operation of the inverter.
- The inverter can become very hot during operation. Install the inverter on a surface that is fire-resistant or flame-retardant and with sufficient clearance around the inverter to allow air to circulate. The illustrations below detail the required installation clearances.

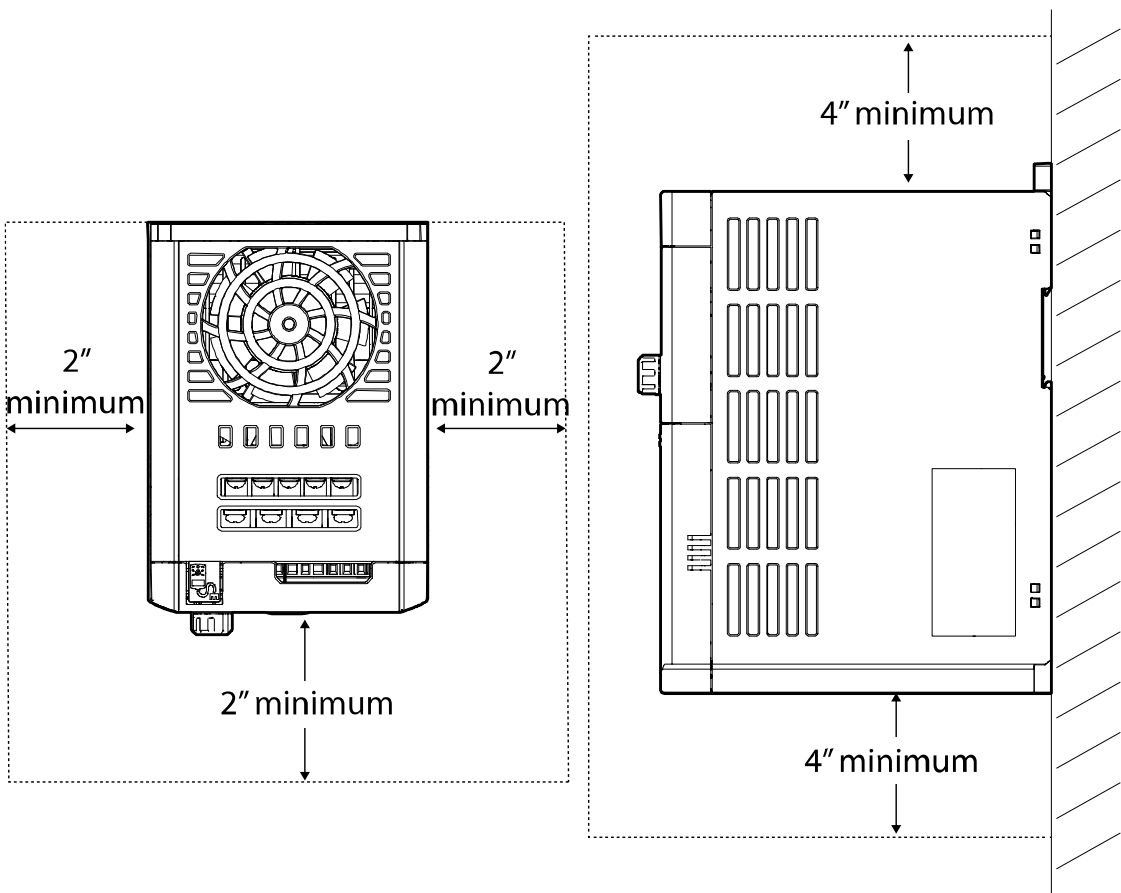

Preparing the Installation

- Ensure sufficient air circulation is provided around the inverter when it is installed. If the inverter is to be installed inside a panel, enclosure, or cabinet rack, carefully consider the position of the inverter's cooling fan and the ventilation louver. The cooling fan must be positioned to efficiently transfer the heat generated by the operation of the inverter.

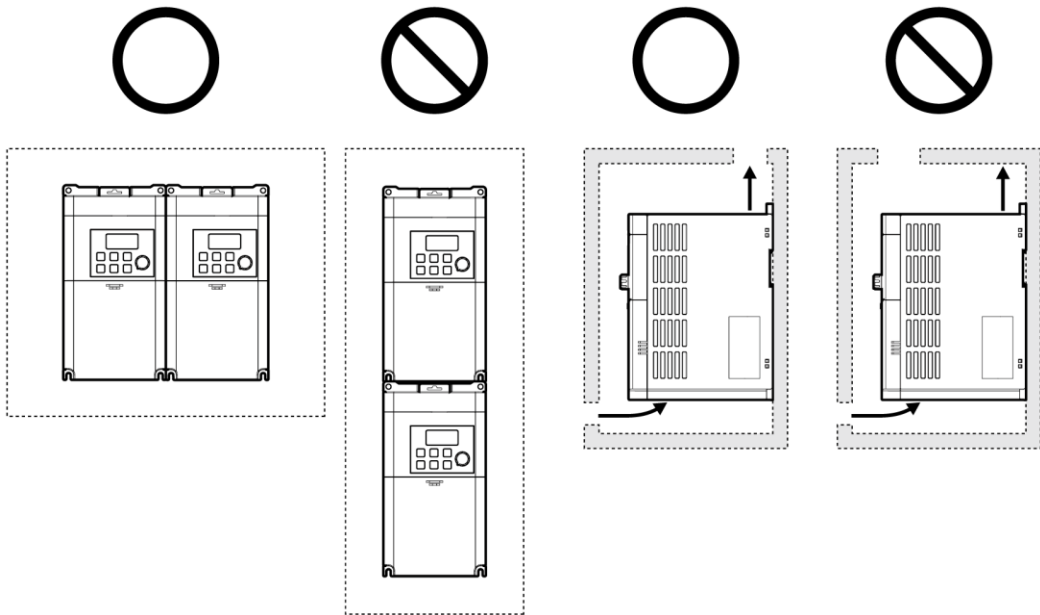

- If you are installing multiple inverters in one location, arrange them side by side and remove their top covers (optional). The top covers **MUST** be removed for side-by-side installations. Use a flat head screwdriver to remove the top covers.
- Keep the distance between inverters at least 0.1”.

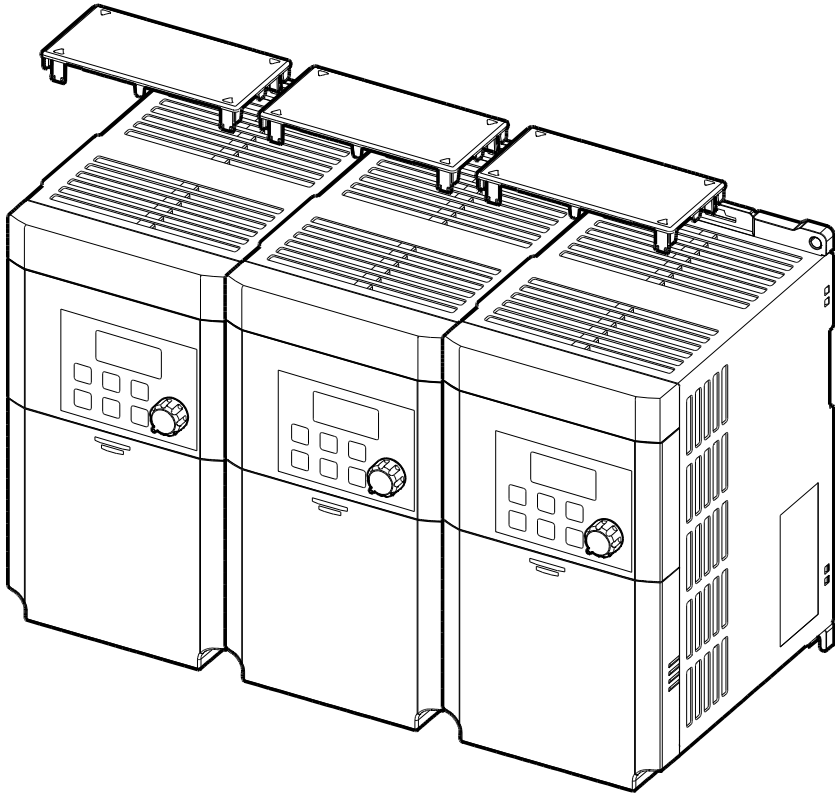

- If you are installing multiple inverters, of different ratings, provide sufficient clearance to meet the clearance specifications of the larger inverter.

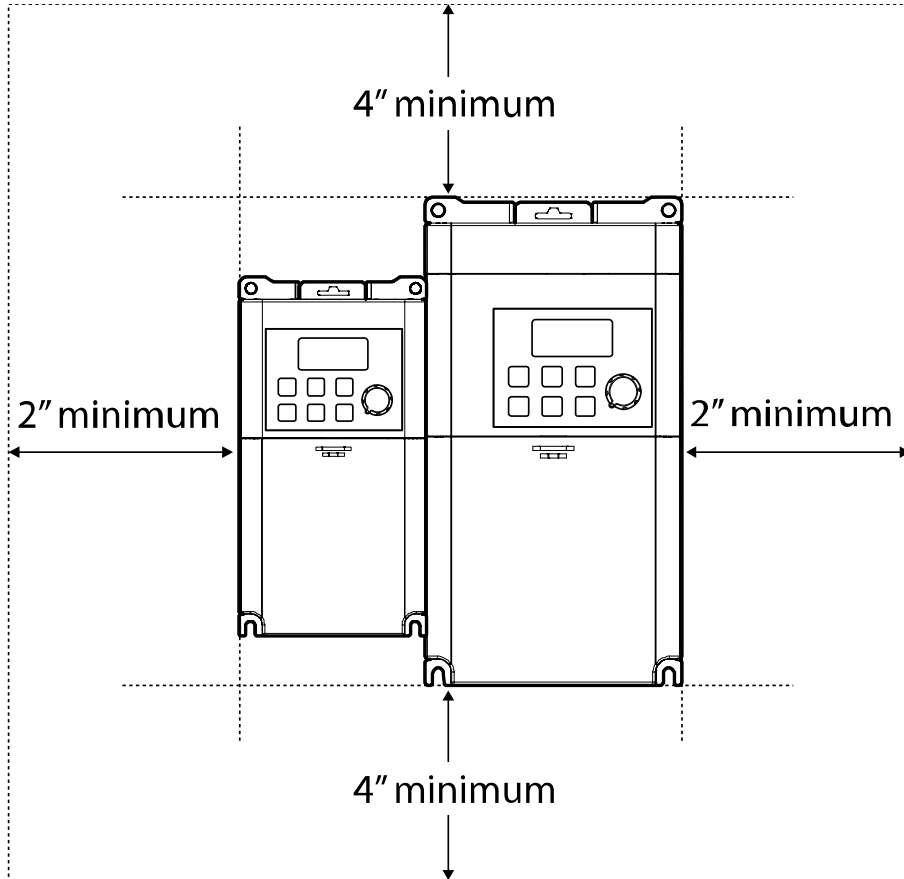

1.5 Cable Selection

When you install power and signal cables in the terminal blocks, only use cables that meet the required specification for the safe and reliable operation of the product. Refer to the following information to assist you with cable selection.

⚠ Caution

- Wherever possible use cables with the largest cross-sectional area for mains power wiring, to ensure that voltage drop does not exceed 2%.
- Use copper cables rated for 600V, 75 °C for power terminal wiring.
- Use copper cables rated for 300V, 75 °C for control terminal wiring.

Ground Cable and Power Cable Specifications

| Load (kW) | Ground | | Power I/O | | | | |
|----------------------|-----------------|-----|-----------------|-------|-------|-------|----|
| | mm ² | AWG | mm ² | | AWG | | |
| | | | R/S/T | U/V/W | R/S/T | U/V/W | |
| Single Phase 200V | 0.1 | 3.5 | 12 | 2 | 2 | 14 | 14 |
| | 0.2 | | | | | | |
| | 0.4 | | | | | | |
| | 0.75 | | | | | | |
| | 1.5 | 3.5 | 12 | 3.5 | 3.5 | 12 | 12 |
| | 2.2 | | | | | | |

Signal (Control) Cable Specifications

| Terminal | Signal Cable | | | |
|----------------------------------------------|-----------------------------------------------|-----|---------------------------------------------------|-----|
| | Without Crimp Terminal Connectors (Bare wire) | | With Crimp Terminal Connectors (Bootlace Ferrule) | |
| | mm ² | AWG | mm ² | AWG |
| P1~P5/CM/VRV1/1/2 /AO/Q1/EG/24 ¹⁾ | 0.75 | 18 | 0.5 | 20 |
| A1/B1/C1/A2/C2 ¹⁾ | 1.0 | 17 | 1.5 | 15 |

1) There are no P4, P5, I2, A2, and C2 terminals on the standard I/O, and there are no Q1 and EG terminals on the Advanced I/O. For more details, refer to [2.2 Cable Wiring Step 4 Control Terminal Wiring](#) on page [24](#).

2 Installing the Inverter

This chapter describes the physical and electrical installation methods, including mounting and wiring of the product. Refer to the flowchart and basic configuration diagram provided below to understand the procedures and installation methods to be followed to install the product correctly.

Installation Flowchart

The flowchart lists the sequence to be followed during installation. The steps cover equipment installation and testing of the product. More information on each step is referenced in the steps.

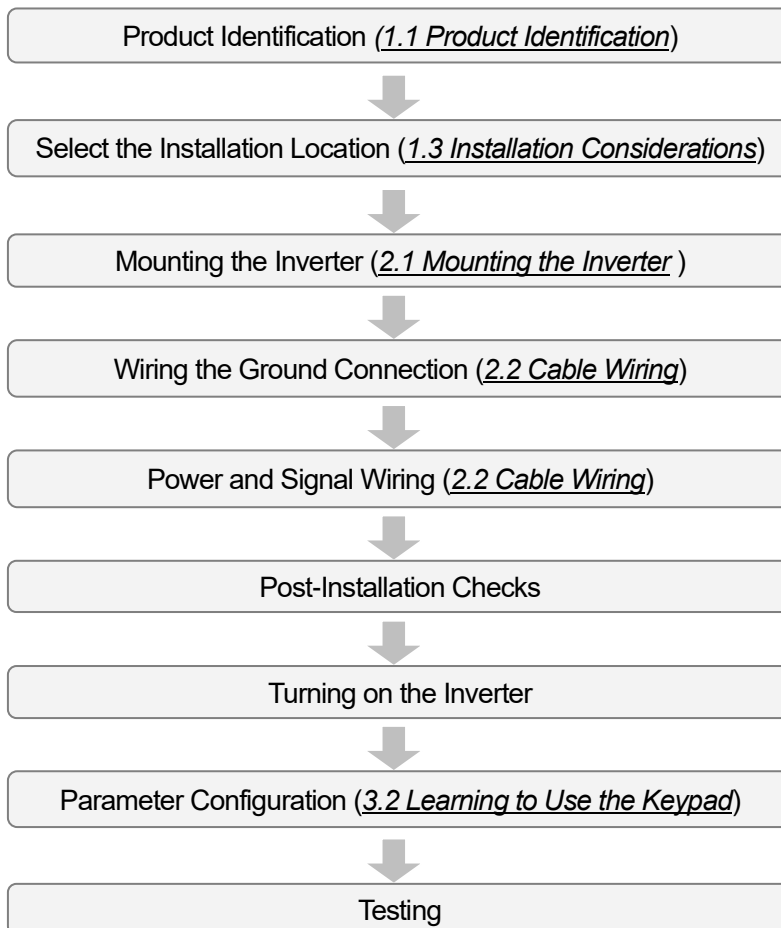

Basic Configuration Diagram

The reference diagram below shows a typical system configuration showing the inverter and peripheral devices.

Prior to installing the inverter, ensure that the product is suitable for the application (power rating, capacity, etc). Ensure that all of the required peripherals and optional devices (resistor brakes, contactors, noise filters, etc.) are available. For more details on peripheral devices, refer to 0 Unit: mm (inches)

Peripheral Devices on page 240.

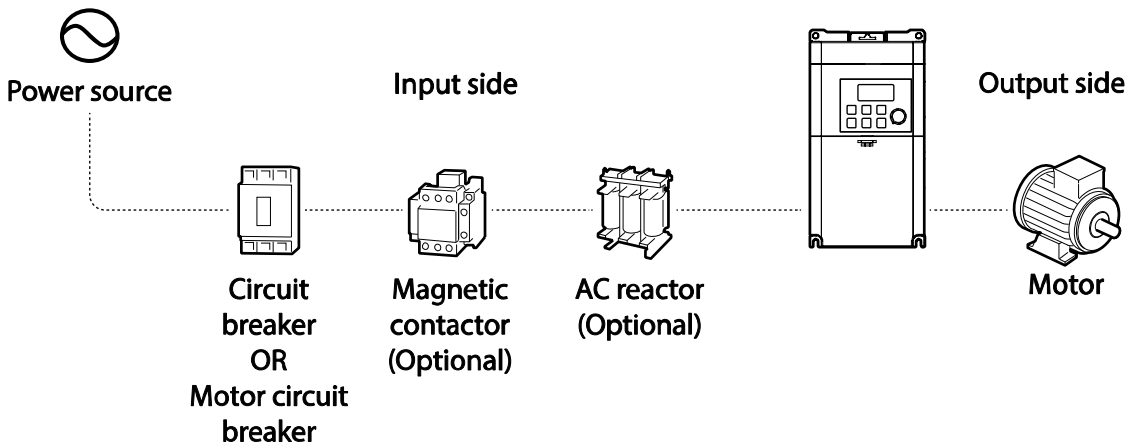

⚠ Caution

- Figures in this manual are shown with covers or circuit breakers removed to show a more detailed view of the installation arrangements. Install covers and circuit breakers before operating the inverter. Operate the product according to the instructions in this manual.
- Do not start or stop the inverter using a magnetic contactor, installed on the input power supply.
- If the inverter is damaged and loses control, the machine may cause a dangerous situation. Install an additional safety device such as an emergency brake to prevent these situations.
- High levels of current draw during power-on can affect the system. Ensure that correctly rated circuit breakers are installed to operate safely during power-on situations.
- Reactors can be installed to improve the power factor. Note that reactors may be installed within 30 ft (9.14 m) from the power source if the input power is 10 times over the inverter's power. Refer to 12.5 Fuse and Reactor Specifications on page 240 and carefully select a reactor that meets the equipment.

2.1 Mounting the Inverter

Mount the inverter on a wall or inside a panel following the procedures provided below. Before installation, ensure that there is sufficient space to meet the clearance specifications, and that there are no obstacles impeding the cooling fan's air flow.

Select a wall or panel suitable to support the installation. Refer to [12.3 External Dimensions \(IP 20 Type\)](#) on page [238](#) and check the inverter's mounting bracket dimensions.

- 1 Use a level to draw a horizontal line on the mounting surface, and then carefully mark the fixing points
- 2 Drill the two upper mounting bolt holes, and then install the mounting bolts. Do not fully tighten the bolts at this time. Fully tighten the mounting bolts after the inverter has been mounted.

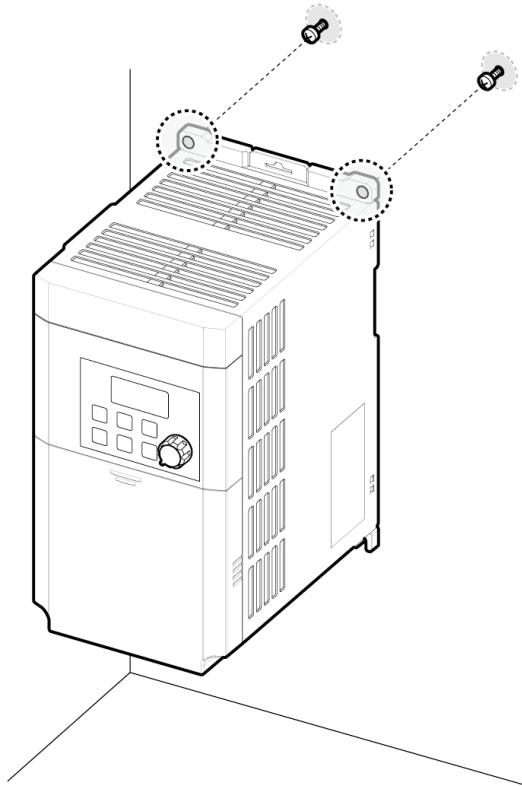

- 3 Mount the inverter on the wall or inside a panel using the two upper bolts, and then fully tighten the mounting bolts. Ensure that the inverter is placed flat on the mounting surface, and that the installation surface can securely support the weight of the inverter.

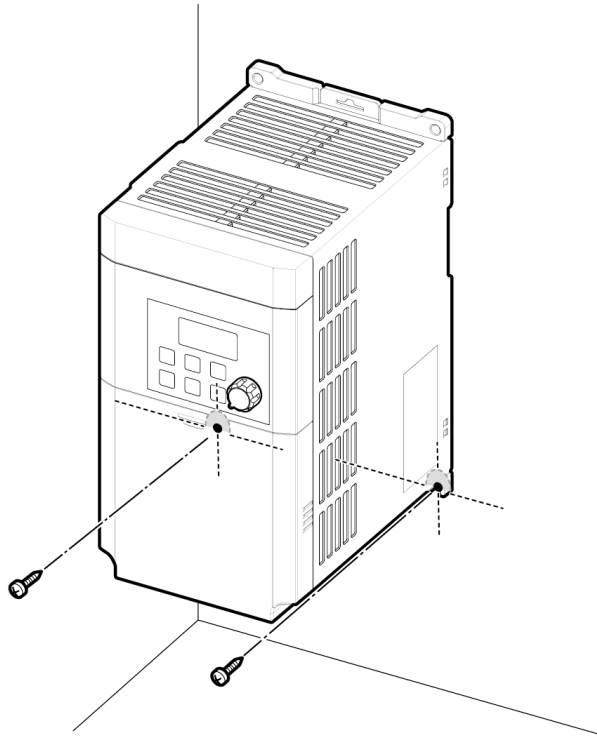

Note

The quantity and dimensions of the mounting brackets vary based on frame size. Refer to [12.3 External Dimensions \(IP 20 Type\)](#) on page [238](#) for detailed information about your model.

⚠ Caution

- Do not transport the inverter by lifting with the inverter's covers or plastic surfaces. The inverter may tip over if covers break, causing injuries or damage to the product. Always support the inverter using the metal frames when moving it.
- Use an appropriate transport method that is suitable for the weight.
- Do not install the inverter on the floor or mount it sideways against a wall. The inverter **MUST** be installed vertically, on a wall or inside a panel, with its rear flat on the mounting surface.

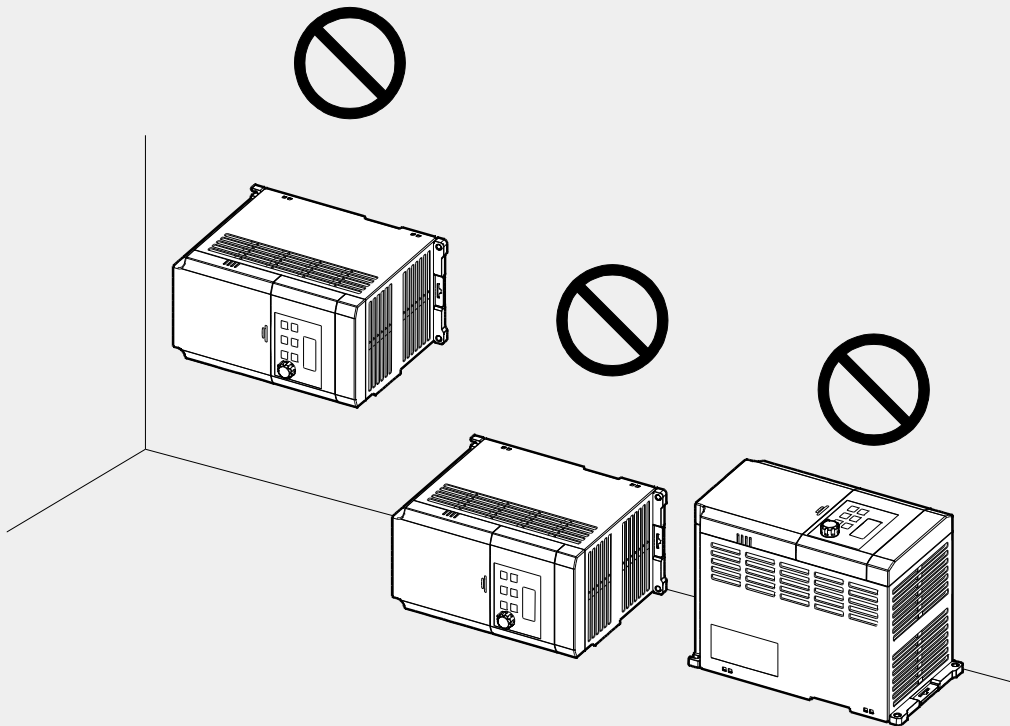

2.2 Cable Wiring

Remove the control terminal cover, and then install the ground connection as specified. Complete the cable connections by connecting an appropriately rated cable to the terminals on the power and control terminal blocks.

⚠ Caution

- Install the inverter before carrying out wiring connections.
- Ensure that no small metal debris, such as wire cut-offs, remain inside the inverter. Metal debris in the inverter may cause inverter failure.
- Tighten terminal screws to their specified torque. Loose terminal block screws may allow the cables to disconnect and cause short circuit or inverter failure. Refer to [12.6 Terminal Screw Specification](#) on page [241](#) for torque specifications.
- Do not place heavy objects on top of electric cables. Heavy objects may damage the cable and result in electric shock.
- The inverter's power is supplied by the supply grounding system. The TT, TN, IT, and corner-grounded systems are not suitable for this inverter.
- The inverter may generate direct current to the inverter's protective ground cable. Only type B Residual Current Devices (RCD) or Residual Current Monitors (RCM) can be installed.
- Use cables with the largest cross-sectional area, appropriate for power terminal wiring, to ensure that voltage drop does not exceed 2%.
- Use copper cables rated at 600V, 75°C for power terminal wiring.
- Use copper cables rated at 300V, 75°C for control terminal wiring.
- Connect the control terminals separately from the power terminal wiring or high potential circuit (200 V relay sequence circuit).
- Ensure that there are no control terminal shorts or improper wiring. Control terminal shorts or improper wiring may damage the inverter or cause malfunction.
- Use a shielded cable while making wiring connections at the control terminal. Unshielded cables may cause the inverter to malfunction due to interference. Use an STP cable if ground connections must be installed.
- If you need to re-wire the terminals due to wiring-related faults, ensure that the inverter keypad display is turned off and the charge lamp under the front cover is off before working on wiring connections. The inverter may hold a high voltage electric charge long after the power supply has been turned off.

Step1 Front Cover, Control Terminal Cover and Cable Guide

The front cover must be removed to install cables.

- 1 Slide the front cover downward while pressing and holding the upper-center part of the cover.

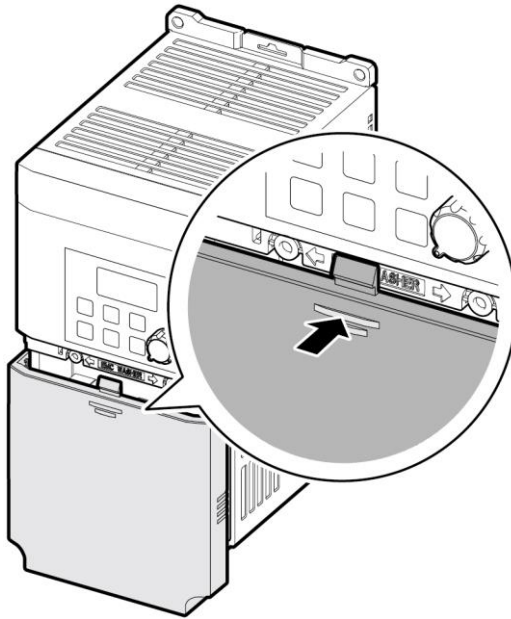

- 2 Remove the cover by lifting it upward from the bottom and moving it away from the front of the inverter.

Note

If you have installed the remote keypad, remove the plastic cover under the lower-right part of the control terminal cover, and then connect the remote keypad signal to the RJ-45 connector.

Step 2 Ground Connection

Remove the control terminal cover, and then follow the instructions below to install the ground connection for the inverter.

- 3 Locate the ground terminal and connect an appropriately rated ground cable to the terminals. Refer to *1.5 Cable Selection* on page 11 to find the appropriate cable specification for your installation.

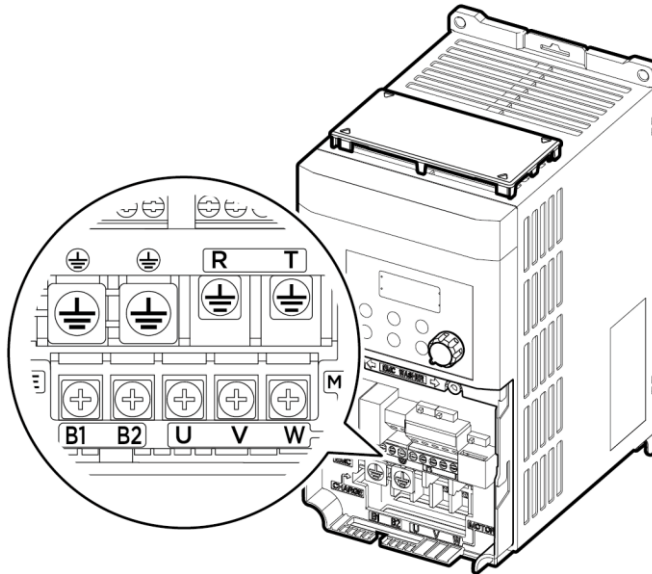

- 4 Connect the other ends of the ground cables to the supply earth (ground) terminal.

Note

Class 3 grounding is required. Resistance to ground must be $< 100\Omega$.

⚠ Warning

Install ground connections for the inverter and the motor by following the correct specifications to ensure safe and accurate operation. Using the inverter and the motor without the specified grounding connections may result in electric shock.

Step3 Power Terminal Wiring

The following illustration shows the terminal layout on the power terminal block. Refer to the detailed descriptions to understand the function and location of each terminal before making wiring connections. Ensure that the cables selected meet or exceed the specifications in [1.5 Cable Selection](#) on page [11](#) before installing them.

⚠ Caution

- Tighten terminal screws to their specified torque. Loose terminal screws may allow the cables to disconnect and cause short circuit or inverter failure. Over tightening terminal screws may damage the terminals and cause short circuits and malfunctions.
- Use copper cables rated for 600V, 75 °C for power terminal wiring.
- Use copper cables rated for 300V, 75 °C for control terminal wiring.
- When making wiring connections at the power terminals, do not make a bi-wired connection to a single terminal.
- Power supply cables must be connected to the R and T terminals. Connecting power cables to the U, V, and W terminals will cause internal damage to the inverter. Connect motors to the U, V, and W terminals. Phase sequence arrangement is not necessary.

⚠ Attention

- Appliquer des couples de marche aux vis des bornes. Des vis desserrées peuvent provoquer des courts-circuits et des dysfonctionnements. Ne pas trop serrer la vis, car cela risqué d'endommager les bornes et de provoquer des courts-circuits et des dysfonctionnements. Utiliser uniquement des fils de cuivre avec une valeur nominale de 600 V, 75 °C pour le câblage de la borne d'alimentation, et une valeur nominale de 300 V, 75 °C pour le câblage de la borne de commande.
- Ne jamais connecter deux câbles à une borne lors du câblage de l'alimentation.
- Les câblages de l'alimentation électrique doivent être connectés aux bornes R, T. Leur connexion aux bornes U, V et W provoque des dommages internes à l'onduleur. Le moteur doit être raccordé aux bornes U, V et W. L'arrangement de l'ordre de phase n'est pas nécessaire.

0.1~0.2 kW (Single Phase)

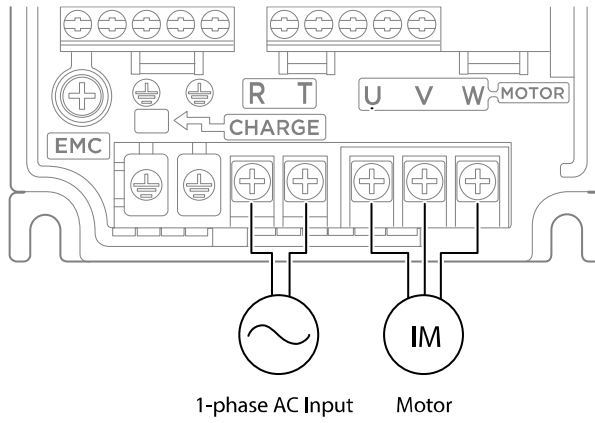

0.4-0.75 kW (Single Phase)

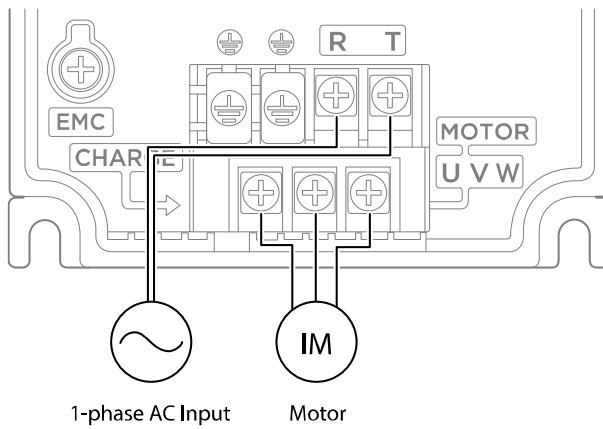

1.5-2.2 kW (Single Phase)

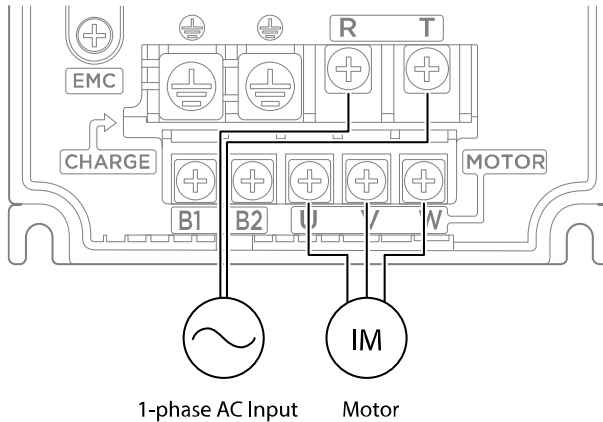

Power Terminal Labels and Descriptions

| Terminal Labels | Name | Description |
|--------------------|----------------------------|---------------------------------------------|
| R/T | AC power input terminal | Mains supply AC power connections. |
| B1/B2(1.5kW~2.2kW) | Braking resistor terminals | Braking resistor wiring connection. |
| U/V/W | Motor output terminals | 3-phase induction motor wiring connections. |

Note

- Use STP (Shielded Twisted Pair) cables to connect a remotely located motor with the inverter. Do not use 3 core cables.
- Ensure that the total cable length does not exceed 165ft (50m).
- Long cable runs can cause reduced motor torque in low frequency applications due to voltage drop. Long cable runs also increase a circuit's susceptibility to stray capacitance and may trigger over-current protection devices or result in malfunction of equipment connected to the inverter.
- Voltage drop is calculated by using the following formula:

$$\text{Voltage Drop (V)} = [\sqrt{3} \times \text{cable resistance (m}\Omega/\text{m)} \times \text{cable length (m)} \times \text{current(A)}] / 1000$$
- Use cables with the largest possible cross-sectional area to ensure that voltage drop is minimized over long cable runs. Lowering the carrier frequency and installing a micro surge filter may also help to reduce voltage drop.

| Distance | < 165 ft (50 m) | < 330 ft (100 m) | > 330 ft (100 m) |
|---------------------------|-----------------|------------------|------------------|
| Allowed Carrier Frequency | < 15 kHz | < 5 kHz | < 2.5 kHz |

Warning

Do not connect power to the inverter until installation has been fully completed and the inverter is ready to be operated. Doing so may result in electric shock.

⚠ Caution

- Power supply cables must be connected to the R and T terminals. Connecting power cables to other terminals will damage the inverter.
- Use insulated ring lugs when connecting cables to R/T and U/V/W terminals.
- The inverter's power terminal connections can cause harmonics that may interfere with other communication devices located near to the inverter. To reduce interference the installation of noise filters or line filters may be required.
- To avoid circuit interruption or damaging connected equipment, do not install phase-advanced condensers, surge protection, or electronic noise filters on the output side of the inverter.
- To avoid circuit interruption or damaging connected equipment, do not install magnetic contactors on the output side of the inverter.

Step 4 Control Terminal Wiring

The illustrations below show the detailed layout of control wiring terminals, and control board switches. Refer to the detailed information provided below and [1.5 Cable Selection](#) on page [11](#) before installing control terminal wiring and ensure that the cables used meet the required specifications.

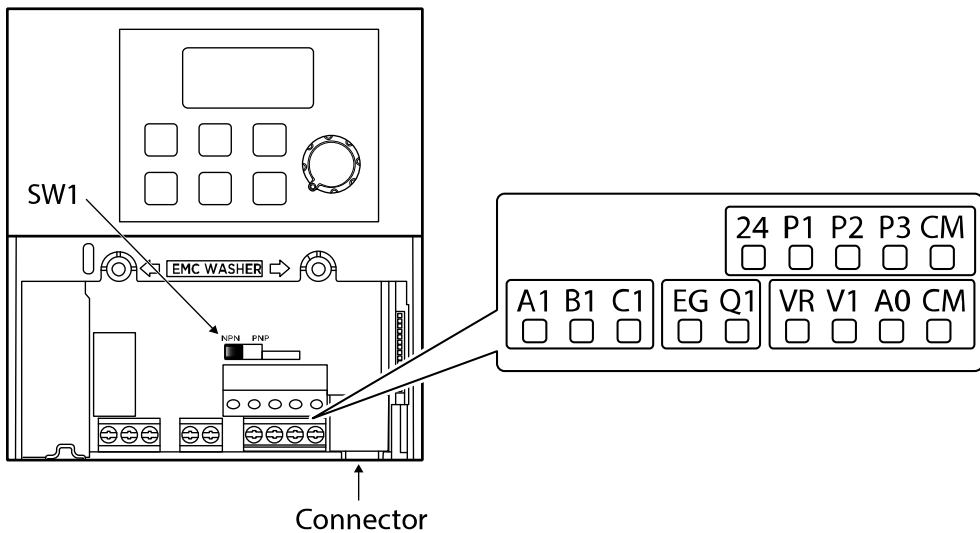

<Standard I/O>

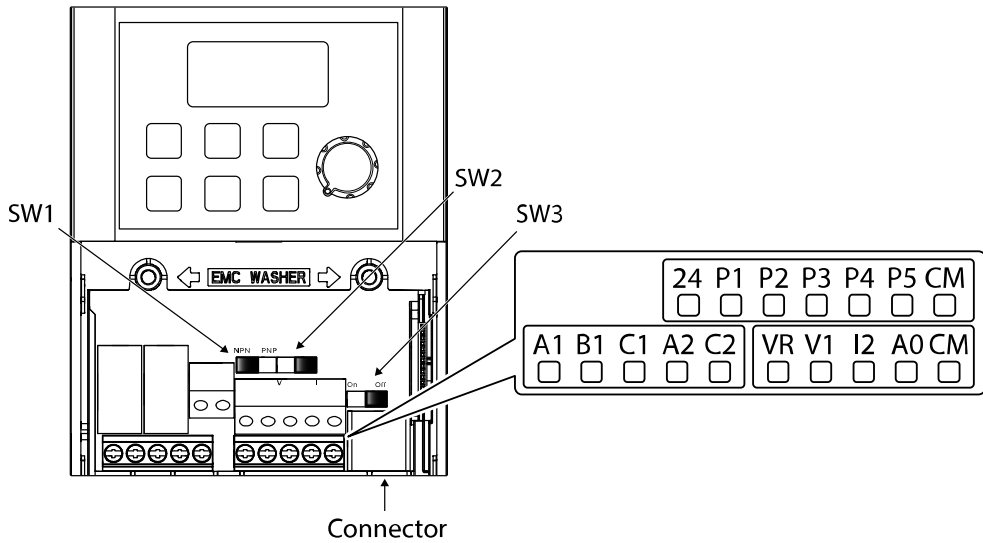

<Advanced I/O>

Control Board Switches

| Switch | Description |
|-------------------|-------------------------------------------------------------|
| SW1 | NPN/PNP mode selection switch |
| SW2(Advanced I/O) | Analog voltage/current input terminal (I2) selection switch |
| SW3(Advanced I/O) | Terminating resistor selection switch |

Connectors

| Connector | Description |
|-----------|--------------------------------------------------------------------------------------|
| Connector | Connection of the remote keypad, Smart Copier, or RS 485 communication (Advanced IO) |

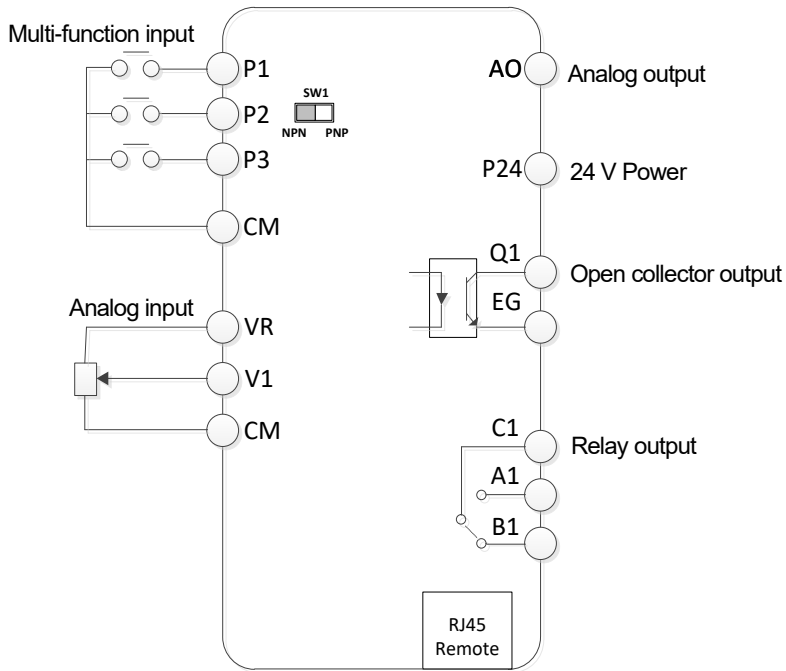

<Standard I/O>

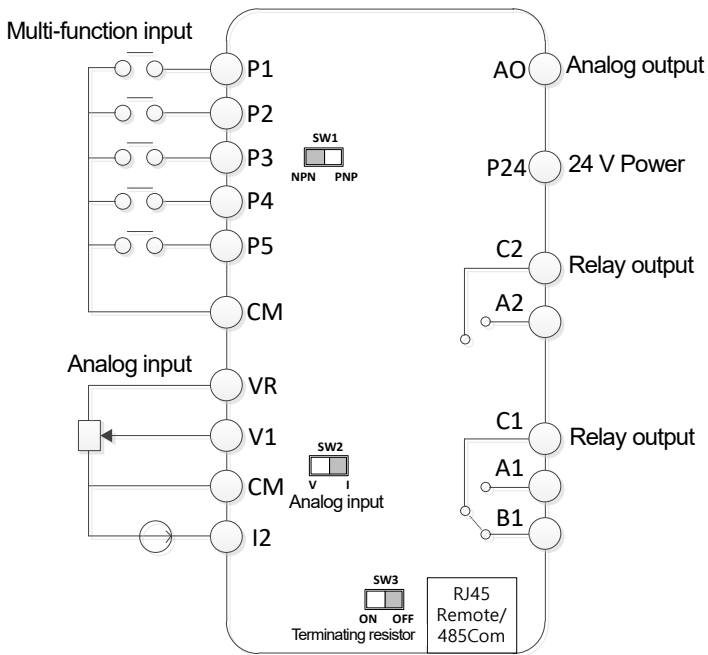

<Advanced I/O>

Input Terminal Labels and Descriptions

| Function | Label | Name | Description |
|---------------------------------------|-------------------|-----------------------------------------------------|----------------------------------------------------------------------------------------------------------------------------------------------------------------------------------------------------------------------------------------------------------------------------------------------------------------------------------------------------------------------------------|
| Multi-function terminal configuration | P1–P5 | Multi-function Input 1-5 | Configurable for multi-function input terminals. Factory default terminals and setup are as follows: <ul style="list-style-type: none"> • P1: Fx • P2: Rx • P3: Emergency stop trip • P4: Fault reset (RESET) • P5: Jog operation command (JOG) (P1-P3 are available for standard I/O.) |
| | CM | Common Sequence | Common terminal for terminal inputs and outputs. |
| Analog input configuration | VR | Potentiometer frequency reference input | Used to setup or modify a frequency reference via analog voltage or current input. <ul style="list-style-type: none"> • Maximum Voltage Output: 12V • Maximum Current Output: 100mA, • Potentiometer: 1–5kΩ |
| | V1 | Voltage input for frequency reference input | Used to setup or modify a frequency reference via analog voltage input terminal. <ul style="list-style-type: none"> • Unipolar: 0–10V (12V Max.) |
| | I2 (Advanced I/O) | Voltage/current input for frequency reference input | Used to setup or modify a frequency reference via analog voltage or current input terminals. Switch between voltage (V2) and current (I2) modes using a control board switch (SW2). <p>V Mode :</p> <ul style="list-style-type: none"> • Unipolar: 0–10 V (12 V Max.) <p>I Mode :</p> <ul style="list-style-type: none"> • Input current : 4–20 mA |

Output/Communication Terminal Labels and Descriptions

| Function | Label | Name | Description |
|----------------|-------------------------|--------------------------------------|-----------------------------------------------------------------------------------------------------------------------------------------------------------------------------------------------------------------------------------------------------------------------------------------------------------------------------------|
| Analog output | AO | Voltage Output | Used to send inverter output information to external devices: output frequency, output current, output voltage, or a DC voltage. <ul style="list-style-type: none"> • Output voltage: 0–10 V • Maximum output voltage/current: 10 V, 10 mA • Factory default output: Output frequency |
| Digital output | Q1 (Standard I/O) | Multi-functional (open collector) | DC 26 V, 100 mA or less |
| | EG (Standard I/O) | Common | Common ground contact for an open collector (with external power source) |
| | 24 | 24 V power source | Maximum output current: 50 mA |
| | A1/C1/B1 | Fault signal output | Sends out alarm signals when the inverter's safety features are activated (AC 250V <1A, DC 30V < 1A). <ul style="list-style-type: none"> • Fault condition: A1 and C1 contacts are connected (B1 and C1 open connection) • Normal operation: B1 and C1 contacts are connected (A1 and C1 open connection) |
| Communication | A2/C2 (Advanced I/O) | Fault signal output | Sends out alarm signals when the inverter's safety features are activated (AC 250V <1A, DC 30V < 1A). <ul style="list-style-type: none"> • Fault condition: A2 and C2 contacts are connected • Normal operation: A2 and C2 contacts are open connection |
| | RJ45 | Remote keypad signal line | Used to send or receive the remote keypad (optional) signals. |
| | | RS-485 signal line (Advanced I/O) | Used to send or receive RS-485 signals. Refer to 8 RS-485 Communication Features on page 171. |

Preinsulated Crimp Terminal Connectors (Bootlace Ferrule)

Use preinsulated crimp terminal connectors to increase reliability of the control terminal wiring. Refer to the specifications below to determine the crimp terminals to fit various cable sizes.

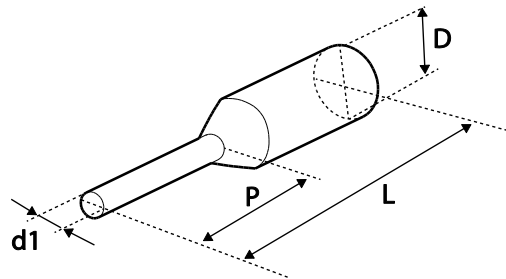

| P/N | Cable Spec. | | Dimensions (inches/mm) | | | | Manufacturer |
|----------|-------------|-----------------|------------------------|------------|------------|-----------|------------------------------------------------------------------------------------------|
| | AWG | mm ² | L* | P | d1 | D | |
| CE002506 | 26 | 0.25 | 0.41/10.4 | 0.24 / 6.0 | 0.04 / 1.1 | 0.10/2.5 | JEONO (Jeono Electric, http://www.jeono.com/) |
| CE002508 | | | 0.49/12.4 | 0.32 / 8.0 | | | |
| CE005006 | 22 | 0.50 | 0.47/12.0 | 0.24 / 6.0 | 0.05 / 1.3 | 0.125/3.2 | |
| CE007506 | 20 | 0.75 | 0.47/12.0 | 0.24 / 6.0 | 0.06 / 1.5 | 0.13/3.4 | |

* If the length (L) of the crimp terminals exceeds 0.5" (12.7mm) after wiring, the control terminal cover may not close fully.

To connect cables to the control terminals without using crimp terminals, refer to the following illustration detailing the correct length of exposed conductor at the end of the control cable.

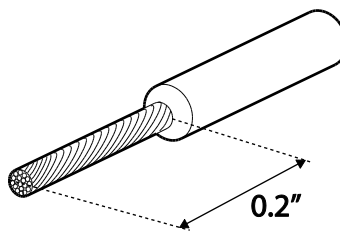

⚠ Caution

Ensure that there is no debris entered inside the inverter.

Note

- While making wiring connections at the control terminals, ensure that the total cable length does not exceed 165ft (50m).
- Ensure that the length of any safety related wiring does not exceed 100 ft (30 m).
- Ensure that the cable length between a remote keypad and the inverter does not exceed 10ft (3.04 m). Cable connections longer than 10 ft (3.04 m) may cause signal errors.
- Use ferrite material to protect signal cables from electro-magnetic interference.
- Take care when supporting cables using cable ties, to apply the cable ties no closer than 6 inches from the inverter. This provides sufficient access to fully close the front cover.
- When making control terminal cable connections, use a small flat-tip screw driver (0.1in wide (2.5mm) and 0.015in thick (0.4mm) at the tip).

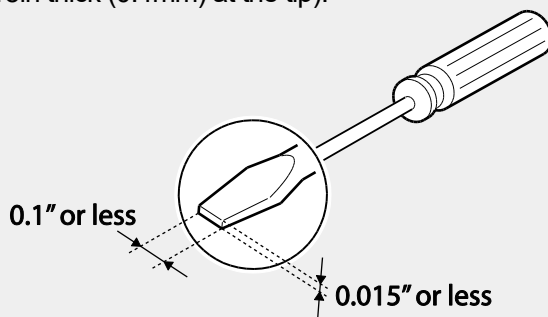

⚠ Warning

When making control terminal cable connections, ensure that the inverter's power is turned off.

Step 5 PNP/NPN Mode Selection

The M100 inverter supports both PNP (Source) and NPN (Sink) modes for sequence inputs at the terminal. Select an appropriate mode to suit requirements using the PNP/NPN selection switch (SW1) on the control board. Refer to the following information for detailed applications.

PNP Mode (Source)

Select PNP using the PNP/NPN selection switch (SW1). Note that the factory default setting is NPN mode. CM is the common ground terminal for all digital inputs at the terminal, and P24 is 24V internal source. If you are using an external 24V source, build a circuit that connects the external source (-) and the CM terminal.

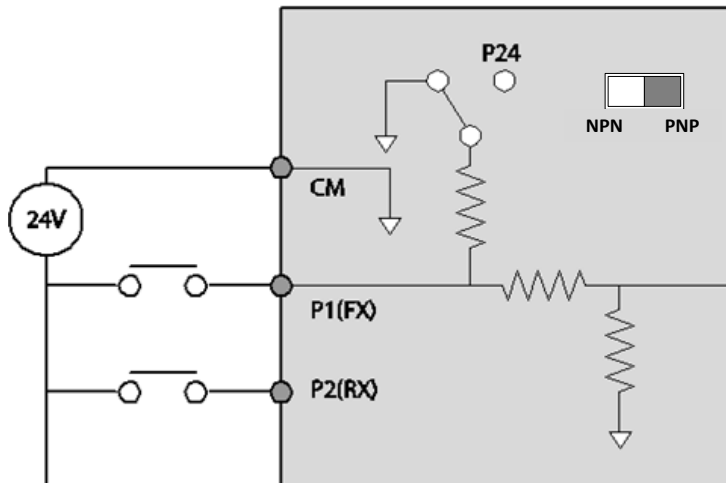

NPN Mode (Sink)

Select NPN using the PNP/NPN selection switch (SW1). CM is the common ground terminal for all analog inputs at the terminal, and P24 is 24V internal source.

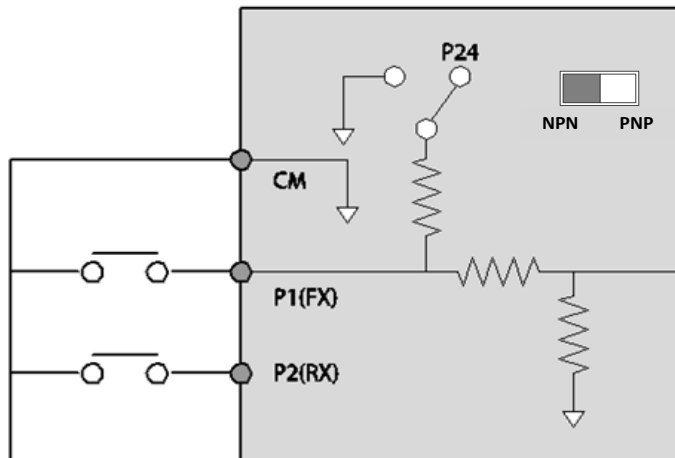

Step 6 Disabling the EMC Filter for Power Sources with Asymmetrical Grounding

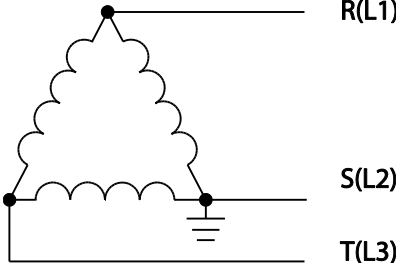
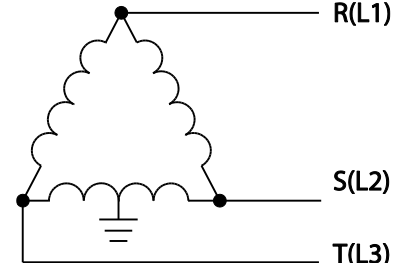
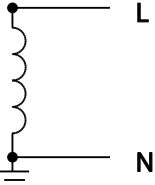
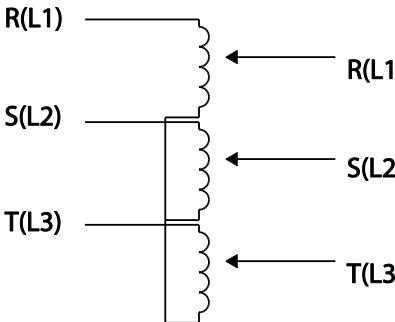

An EMC filter prevents electromagnetic interference by reducing radio emissions from the inverter. EMC filter use is not always recommended, as it increases leakage current. If an inverter uses a power source with an asymmetrical grounding connection, the EMC filter **MUST** be turned off.

| Asymmetrical Grounding Connection | | | |
|----------------------------------------------------|------------------------------------------------------------------------------------|------------------------------------------------------------------------|-------------------------------------------------------------------------------------|
| <p>One phase of a delta connection is grounded</p> |  | <p>Intermediate grounding point on one phase of a delta connection</p> |  |
| <p>The end of a single phase is grounded</p> |  | <p>A 3-phase connection without grounding</p> |  |

⚠ Danger

- Do not activate the EMC filter if the inverter uses a power source with an asymmetrical grounding structure, for example a grounded delta connection. Personal injury or death by electric shock may result.
- Wait at least 10 minutes before opening the covers and exposing the terminal connections. Before starting work on the inverter, test the connections to ensure all DC voltage has been fully discharged. Personal injury or death by electric shock may result.

Before using the inverter, confirm the power supply's grounding system. Disable the EMC filter if the power source has an asymmetrical grounding connection. Check the location of the EMC filter on/off screw and attach the plastic washer to the screw under the control terminal block.

| Steel bolt | Steel bolt + Plastic washer |
|-----------------------------------------------------------------------------------|-----------------------------------------------------------------------------------|
|  |  |
| EMC ON | EMC OFF |

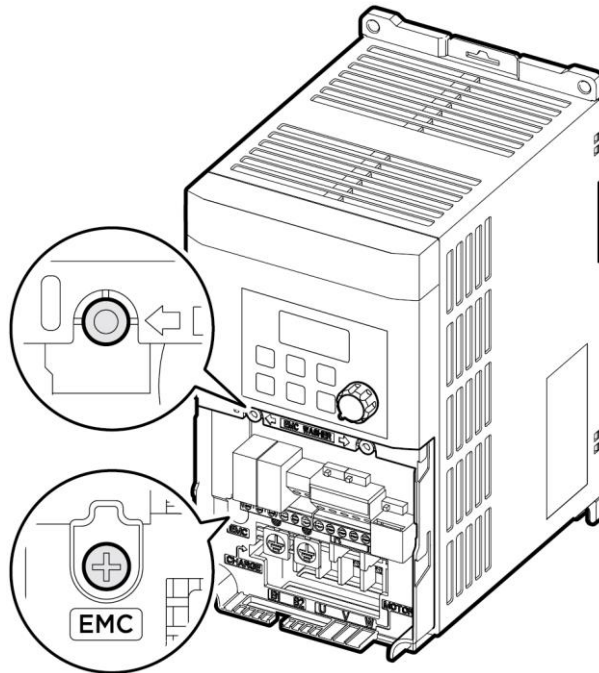

Step 7 Re-assembling the Cover

Re-assemble the cover after completing the wiring and basic configuration.

2.3 Post-Installation Checklist

After completing the installation, check the items in the following table to make sure that the inverter has been safely and correctly installed.

| Items | Check Point | Result |
|----------------------------------------------|-------------------------------------------------------------------------------------------------------------------------------------------------------------------------------------------------|--------|
| Installation Location/Power I/O Verification | Is the installation location appropriate? | |
| | Does the environment meet the inverter's operating conditions? | |
| | Does the power source match the inverter's rated input? | |
| | Is the inverter's rated output sufficient to supply the equipment? | |
| Power Terminal Wiring | Is a circuit breaker installed on the input side of the inverter? | |
| | Is the circuit breaker correctly rated? | |
| | Are the power source cables correctly connected to the R/S/T terminals of the inverter? (Caution: connecting the power source to the U/V/W terminals may damage the inverter.) | |
| | Are the motor output cables connected in the correct phase rotation (U/V/W)? (Caution: motors will rotate in reverse direction if three phase cables are not wired in the correct rotation.) | |
| | Are the cables used in the power terminal connections correctly rated? | |
| | Is the inverter grounded correctly? | |
| | Are the power terminal screws and the ground terminal screws tightened to their specified torques? | |
| | Are the overload protection circuits installed correctly on the motors (if multiple motors are run using one inverter)? | |
| | Is the inverter separated from the power source by a magnetic contactor (if a braking resistor is in use)? | |
| | Are advanced-phase capacitors, surge protection and electromagnetic interference filters installed correctly? (These devices MUST not be installed on the output side of the inverter.) | |

| Items | Check Point | Result |
|-------------------------|----------------------------------------------------------------------------------------------------------------------------------------------|--------|
| Control Terminal Wiring | Are STP (shielded twisted pair) cables used for control terminal wiring? | |
| | Is the shielding of the STP wiring properly grounded? | |
| | If 3-wire operation is required, are the multi-function input terminals defined prior to the installation of the control wiring connections? | |
| | Are the control cables properly wired? | |
| | Are the control terminal screws tightened to their specified torques? | |
| | Is the total cable length of all control wiring < 165 ft (100 m)? | |
| | Is the total length of safety wiring < 100 ft (30 m)? | |
| Miscellaneous | Are optional cards connected correctly? | |
| | Is there any debris left inside the inverter? | |
| | Are any cables contacting adjacent terminals, creating a potential short circuit risk? | |
| | Are the control terminal connections separated from the power terminal connections? | |
| | Have the capacitors been replaced if they have been in use for > 2 years? | |
| | Has the fan been replaced if it has been in use for > 3 years? | |
| | Has a fuse been installed for the power source? | |
| | Are the connections to the motor separated from other connections? | |

Note

STP (Shielded Twisted Pair) cable has a highly conductive, shielded screen around twisted cable pairs. STP cables protect conductors from electromagnetic interference.

2.4 Test Run

After the post-installation checklist has been completed, follow the instructions below to test the inverter.

- 1 Turn on the power supply to the inverter. Ensure that the keypad display light is on.
- 2 Select the command source.
- 3 Set a frequency reference, and then check the following:
 - If V1 is selected as the frequency reference source, does the reference change according to the input voltage at VR?
 - If I2 (V)¹⁾ is selected as the frequency reference source, is the voltage/current selector switch (SW2)¹⁾ set to voltage??
 - If I2 (V)¹⁾ is selected as the frequency reference source, does the reference change according to the input voltage at VR?
 - If I2 (I)¹⁾ is selected as the frequency reference source, is the voltage/current selector switch (SW2)¹⁾ set to current?
 - If I2 (I)¹⁾ is selected as the frequency reference source, does the reference change according to the input current?
- 4 Set the acceleration and deceleration time.
- 5 Start the motor and check the following:
 - Ensure that the motor rotates in the correct direction (refer to the note below).
 - Ensure that the motor accelerates and decelerates according to the set times, and that the motor speed reaches the frequency reference.

1) Available only for models equipped with advanced I/O.

Verifying the Motor Rotation

- 1 On the keypad, set the drv (Command source) code in the Operation group to 0 (Keypad).
- 2 Set a frequency reference.
- 3 Press the [RUN] key. Motor starts forward operation.
- 4 Observe the motor's rotation from the load side and ensure that the motor rotates counterclockwise (forward).

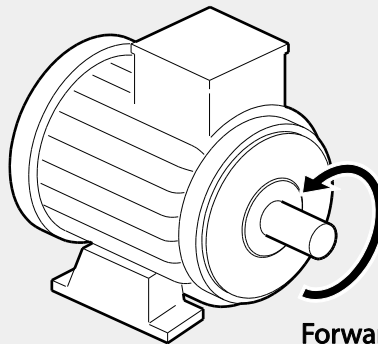

Forward operation

⚠ Caution

- Check the parameter settings before running the inverter. Parameter settings may have to be adjusted depending on the load.
- To avoid damaging the inverter, do not supply the inverter with an input voltage that exceeds the rated voltage for the equipment.
- Before running the motor at maximum speed, confirm the motor's rated capacity. As inverters can be used to easily increase motor speed, use caution to ensure that motor speeds do not accidentally exceed the motor's rated capacity.

3 Learning to Perform Basic Operations

This chapter describes the keypad layout and functions. It also introduces parameter groups and codes, required to perform basic operations. The chapter also outlines the correct operation of the inverter before advancing to more complex applications. Examples are provided to demonstrate how the inverter actually operates.

3.1 About the Keypad

The keypad is composed of two main components – the display and the operation (input) keys. Refer to the following illustration to identify part names and functions.

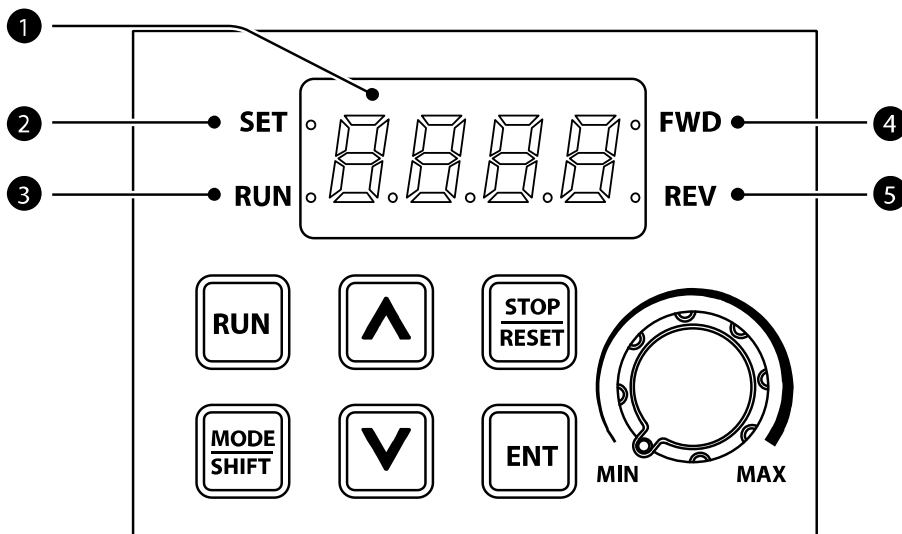

3.1.1 About the Display

The following table lists display part names and their functions.







| No. | Name | Function |
|-----|-------------------|---------------------------------------------------------------------------------------------|
| ❶ | 7-Segment Display | Displays current operational status and parameter information. |
| ❷ | SET Indicator | LED flashes during parameter configuration. |
| ❸ | RUN Indicator | LED turns on (steady) during an operation, and flashes during acceleration or deceleration. |
| ❹ | FWD Indicator | LED turns on (steady) during forward operation. |
| ❺ | REV Indicator | LED turns on (steady) during reverse operation. |

The table below lists the way that the keypad displays characters (letters and numbers).

| Display | Number/ character | Display | Number/ character | Display | Number/ character | Display | Number/ character |
|---------|----------------------|---------|----------------------|---------|----------------------|---------|----------------------|
| 0 | 0 | A | A | K | K | U | U |
| 1 | 1 | b | B | L | L | v | V |
| 2 | 2 | C | C | m | M | W | W |
| 3 | 3 | d | D | n | N | X | X |
| 4 | 4 | E | E | O | O | Y | Y |
| 5 | 5 | F | F | P | P | Z | Z |
| 6 | 6 | G | G | Q | Q | 0 (bit) | 0 (bit) |
| 7 | 7 | H | H | R | R | 1 (bit) | 1 (bit) |
| 8 | 8 | I | I | S | S | - | - |
| 9 | 9 | J | J | T | T | - | - |

3.1.2 Operation Keys

The following table lists the names and functions of the keypad's operation keys.

| Key | Name | Description |
|------------------------------------------------------------------------------------|------------------|-----------------------------------------------------------------------------------------------------------------------------------------------------------------|
|  | [RUN] key | Used to run the inverter (inputs a RUN command). |
|  | [STOP/RESET] key | STOP: stops the inverter. RESET: resets the inverter following fault or failure condition. |
|  | [▲] key, [▼] key | Switch between codes, or to increase or decrease parameter values. |
|  | [MODE/SHIFT] key | Switch between groups, or to move the cursor during parameter setup or modification. |
|  | [ENTER] key | Used to enter the parameter setting mode, apply the set parameter, and enter the operation information screen from the fault notice screen when a fault occurs. |
|  | [Volume] key | Used to set the operation frequency. |

* Operates as ESC key if two keys out of [MODE/SHIFT] key, [▲] key and [▼] key are entered at the same time.

- Press ESC in the group navigation mode to go to the initial screen (the frequency display screen).
- Press ESC in the mode to change parameter to go to group navigation mode without saving.

3.1.3 Control Menu

The M100 inverter control menu uses the following groups.

| Group | Display | Description |
|---------------------------------------------------|-----------|-------------------------------------------------------------------------------------------------------------------------------------------------------------------------------------------------------------------------------------------------------------|
| Operation | - | Configures basic parameters for inverter operation. |
| Drive (D rive) | <i>dr</i> | Configures parameters for basic operations. These include jog operation, torque boost, and other parameters. |
| Basic (B asic) | <i>bA</i> | Configures basic parameters, including motor-related parameters and multi-step frequencies. |
| Advanced (A dvanced) | <i>Ad</i> | Configure acceleration or deceleration patterns and to setup frequency limits. |
| Control (C ontrol) | <i>Cn</i> | Configures functions such as carrier frequency or speed search. |
| Input Terminal (I nput) | <i>In</i> | Configures input terminal-related features, including digital multi-functional inputs and analog inputs. |
| Output Terminal (O utput) | <i>OU</i> | Configures output terminal-related features such as relays and analog outputs. |
| Communication (C ommunication) | <i>Cn</i> | Configures communication features for RS-485 or other communication options. ※ Available only for models equipped with advanced I/O. |
| Application (A pplication) | <i>AP</i> | Configures PID control-related sequences and operations. |
| Protection (P rotection) | <i>Pr</i> | Configures motor or inverter protection features. |
| Secondary Motor (2nd Motor) | <i>M2</i> | Configures secondary motor related features. ※ The secondary motor (M2) group appears on the keypad only when one of the multi-function input terminals (standard I/O model: In65-67, advanced I/O model: In65-69) has been set to 12 (Secondary motor). |
| Configuration (C onfiguration) | <i>CF</i> | Configures various features such as parameter setting, |



3.2 Learning to Use the Keypad

3.2.1 Group Selection

※ Groups, except the Operation group, are not displayed on the group list and not accessible as factory default to prevent parameter input error. To display and access all groups, go to the OGr code in the Operation group and set the parameter to 1.

Press the [MODE] key for longer than 1 second to move in the opposite direction.

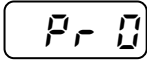
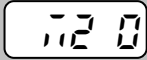
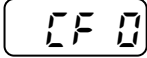
| Step | Instruction | Keypad Display |
|------|------------------------------------------------------------------------------------------------------------------------------------------------------------------------------------------------------------------------|----------------|
| 1 | <ul style="list-style-type: none"> '0.00'¹⁾, the initial code of the Operation group, is displayed when the inverter is turned on. Press the [MODE] key. | |
| 2 | <ul style="list-style-type: none"> 'dr 0', the initial code of the Drive (dr) group, is displayed. Press the [MODE] key. | |
| 3 | <ul style="list-style-type: none"> 'bA 0', the initial code of the Basic (bA) group, is displayed. Press the [MODE] key. | |
| 4 | <ul style="list-style-type: none"> 'Ad 0', the initial code of the Advanced (Ad) group, is displayed. Press the [MODE] key. | |
| 5 | <ul style="list-style-type: none"> 'Cn 0', the initial code of the Control (Cn) group, is displayed. Press the [MODE] key. | |
| 6 | <ul style="list-style-type: none"> 'In 0', the initial code of the Input Terminal, is displayed. Press the [MODE] key. | |
| 7 | <ul style="list-style-type: none"> 'OU 0', the initial code of the Output Terminal, is displayed. Press the [MODE] key. | |
| 8 | <ul style="list-style-type: none"> 'CM 0', the initial code of the Communication group (CM) is displayed. Press the [MODE] key. <p>※ Available only for models equipped with advanced I/O.</p> | |

| Step | Instruction | Keypad Display |
|------|----------------------------------------------------------------------------------------------------------------------------------------------------------------------------------------------------------------------------------------------------------------------------------------------------------------------------------------------------------------------------------------------------------------------------|--------------------------------------------------------------------------------------|
| 9 | <ul style="list-style-type: none"> 'AP 0', the initial code of the Application (AP) group, is displayed. Press the [MODE] key. |  |
| 10 | <ul style="list-style-type: none"> 'Pr 0', the initial code of the Protection (Pr) group, is displayed. Press the [MODE] key. |  |
| 11 | <ul style="list-style-type: none"> 'M2-0', the initial code of the Secondary Motor group, is displayed. Press the [MODE] key. <p>※ This group is available when the secondary motor function is enabled.</p> <p>※ To enable the secondary motor function, set one of the multi-function input terminal's codes (standard I/O model: In 65-67, advanced I/O model: In 65-69) to I2 (2nd Motor).</p> |  |
| 12 | <ul style="list-style-type: none"> 'CF 0', the initial code of the Configuration (CF) group, is displayed. Press the [MODE] key. |  |
| 13 | <ul style="list-style-type: none"> Press the [MODE] key at the Configuration group, and then '0.00' (the initial code of the Operation group) will be displayed. |  |

1) You can set reference frequencies at the initial code of the Operation group. The initial code is set to 0.00 as factory default. After you set the frequency reference, the set value will be displayed.

3.2.2 Code Selection

Follow the example below to learn how to switch between codes. This example applies to all groups whenever you would like to switch to a specific code number.

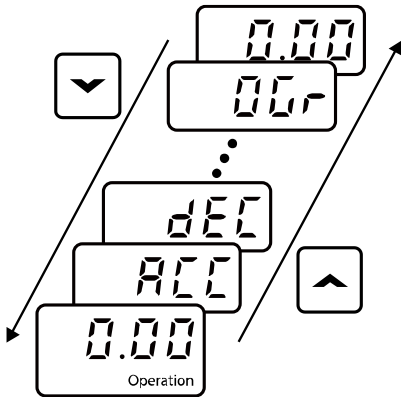

| Step | Instruction | Keypad Display |
|------|----------------------------------------------------------------------------------------------------------------------------------------------------|----------------|
| 1 | <ul style="list-style-type: none"> '0.00', the initial code of the Operation group, is displayed. Press the [▲] key. | |
| 2 | <ul style="list-style-type: none"> 'ACC', the second code of the Operation group, will be displayed. Press the [▲] key. | |
| 3 | <ul style="list-style-type: none"> 'dEC', the third code of the Operation group, will be displayed. Press the [▲] key. | |
| 4 | <ul style="list-style-type: none"> 'OGr', the last code of the Operation group will be displayed. Press the [▲] key again. | |
| 5 | The initial code '0.00' will be displayed again. | |

Note

Press the [▼] key to switch between codes in the opposite direction.

3.2.3 Navigating Directly to Different Codes

The following example details navigating to code Ad12, from the initial code in the Advanced group (Ad 0). This example applies to all groups whenever you would like to navigate to a specific code number.

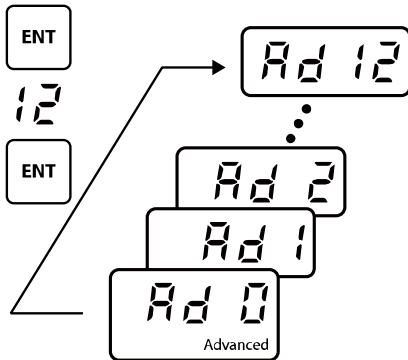

| Step | Instruction | Keypad Display |
|------|--------------------------------------------------------------------------------------------------------------------------------------------------------------------------------------------------------------------------------------------------------------------------------------------------------------------------------------------|----------------|
| 1 | <ul style="list-style-type: none"> 'Ad 0', the initial code of the Advanced (Ad) group, is displayed. Press the [ENT] key. | |
| 2 | <ul style="list-style-type: none"> The code often used for the group will be displayed as default. For example, '24' is displayed as a default code of the Ad group. The first digit will be flashing. This indicates the flashing value is ready to be modified. Press the [▼] key to set the first digit to '2'. | |
| 3 | <ul style="list-style-type: none"> Press the [MODE] key. The cursor will move to the left and the tenth digit will be flashing. Press the [▼] key to change '2' to '1'. | |
| 4 | <ul style="list-style-type: none"> The code destination '12' will be displayed. Press the [ENT] key. | |
| 5 | The 12 th code of the Advanced (Ad) group will be displayed. | |

Note

This example applies to all groups except the Operation group.

3.2.4 Switching to a Different Code

The following example details switching to code Ad 12 from Ad 1. This example applies to all groups whenever you would like to switch to a specific code number.

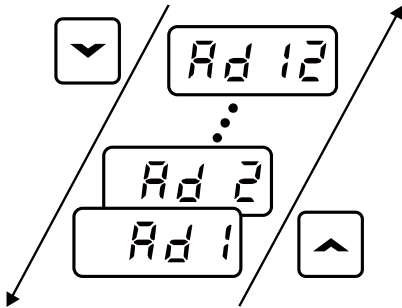

| Step | Instruction | Keypad Display |
|------|---------------------------------------------------------------------------------------------------------------------------------------------------------------------------|----------------|
| 1 | <ul style="list-style-type: none"> The 1st code of the Advanced (Ad) group, is displayed. Press the [ENT] key until Ad12 is displayed. | |
| 2 | The 12 th code of the Advanced (Ad) group will be displayed. | |

Note

In some instances, the code number increases or decreases by more than 1 when you press the [▲] or [▼] key, as some codes have no assigned function or may not be accessible. This is when a new function is required to be assigned. Refer to 9 Table of Functions on page 189 for more information.

Example) When you switch the code of the Advanced group while the Ad24 (Frequency upper/lower limit options) code is set to 0 (No), the Ad25 (Frequency upper limit) and Ad26 (Frequency lower limit) codes are not accessible. When the Ad24 code is set to 1 (Yes), the Ad25 and Ad26 codes are accessible.

3.2.5 Setting Parameter Values

Enable or disable features by setting or modifying parameter values for different codes. Directly enter setting values, such as frequency references, supply voltages, and motor speeds. Follow the instructions below to learn to set or modify parameter values.

| Step | Instruction | Keypad Display |
|------|-----------------------------------------------------------------------------------------------------------------------------------------------------------------------------------------------------------------------------------------------------------------------------|------------------|
| 1 | <ul style="list-style-type: none"> Select the group and code to setup and modify parameter settings, and then press the [ENT] key. Each digit of the parameter value will be flashing. This indicates the flashing values are ready to be modified. | |
| 2 | Press the [▲] or [▼] key to move the cursor to the number that you would like to modify and then press the [MODE] key. | |
| 3 | <ul style="list-style-type: none"> The parameter value will flash on the display. Press the [ENT] key. | |
| 4 | Press the [ENT] key again to save the change. | |

Note

A flashing number on the display indicates that the keypad is waiting for an input from the user. Changes will be saved when the [ENT] key is pressed while the number is flashing. The setting change will be canceled if you press any other key.

3.3 Actual Application Examples

3.3.1 Acceleration Time Configuration

The following is an example demonstrating how to modify the ACC (Acceleration time) code value (from 5.0 to 16.0) from the Operation group.

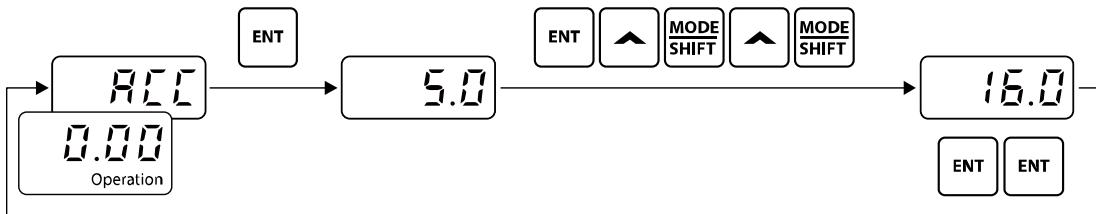

| Step | Instruction | Keypad Display |
|------|----------------------------------------------------------------------------------------------------------------------------------------------------------------------------------------------|----------------|
| 1 | <ul style="list-style-type: none"> The initial code of the Operation group is displayed. Press the [▲] key. | 0.00 |
| 2 | <ul style="list-style-type: none"> ACC (acceleration time), the second code of the Operation group, will be displayed. Press the [ENT] key. | ACC |
| 3 | <ul style="list-style-type: none"> '5.0' will be displayed and '0' will be flashing. Press the [MODE] key. | 5.0 |
| 4 | <ul style="list-style-type: none"> '5' will be flashing. This indicates the flashing value '5' is ready to be modified. Press the [▲] key. | 5.0 |
| 5 | <ul style="list-style-type: none"> The parameter value is set to '6.0'. Press the [MODE] key. | 6.0 |
| 6 | <ul style="list-style-type: none"> '0' is displayed as the first digit and will be flashing. Press the [▲] key. | 06.0 |
| 7 | <ul style="list-style-type: none"> '16.0' will be displayed. '16.0' will be flashing¹⁾. Press the [ENT] key. Press the [ENT] key again. | 16.0 |
| 8 | ACC will be displayed and the acceleration time is set to '16.0'. | ACC |

1) You can cancel setting the parameter by pressing any key except the [ENT] key while '16.0' is flashing.

3.3.2 Frequency Reference Configuration

The following is an example to demonstrate configuring a frequency reference of 30.05 (Hz) from the first code in the Operation group (0.00).

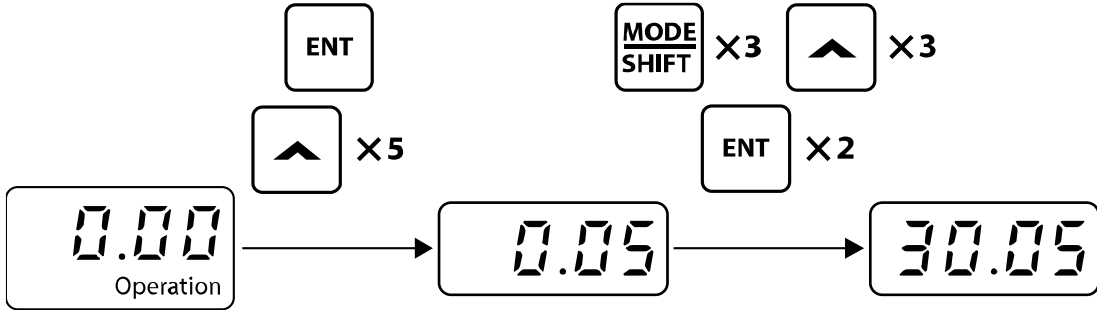

| Step | Instruction | Keypad Display |
|------|-----------------------------------------------------------------------------------------------------------------------------------------------------------------------------------------------|----------------|
| 1 | <ul style="list-style-type: none"> The initial code of the Operation group is displayed. Press the [ENT] key. | |
| 2 | <ul style="list-style-type: none"> The digit in the second decimal place becomes editable. Press the [▲] key until the digit in the second decimal place reaches '5'. | |
| 3 | Press the [MODE] key. | |
| 4 | <ul style="list-style-type: none"> The cursor is moved to the left. Press the [MODE] key. | |
| 5 | Press the [MODE] key. | |
| 6 | Press the [▲] key to set the first digit to '3'. | |
| 7 | <ul style="list-style-type: none"> Press the [ENT] key. '30.05' will flash. | |
| 8 | <ul style="list-style-type: none"> Press the [ENT] key. The value will stop flashing. This indicates that the frequency reference is set to '30.05'. | |

Note

The M100 inverter keypad display can display up to 4 digits. However, 5-digit figures can be used and are accessed by pressing the [MODE] key, to allow keypad input. In step 7, you can cancel setting the parameter by pressing any key except the [ENT] key while '30.05' is flashing.

3.3.3 Frequency Setting

The following is an example demonstrating how to modify the Ad 27 code value (from 0 to 1) from the Advanced group.

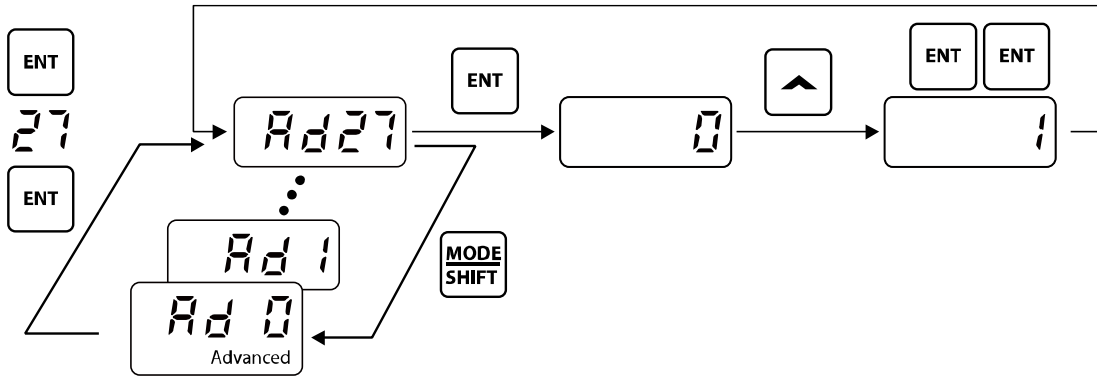

| Step | Instruction | Keypad Display |
|------|-----------------------------------------------------------------------------------------------------------------------------------------------------------------|----------------|
| 1 | <ul style="list-style-type: none"> 'Ad 0', the initial code of the Advanced group, is displayed. Press the [ENT] key. | Ad 0 |
| 2 | <ul style="list-style-type: none"> The code value '24' will be displayed. Press the [▲] key until the first digit reaches '7'. | 24 |
| 3 | <ul style="list-style-type: none"> The code value '27' will be displayed. Press the [ENT] key. | 27 |
| 4 | <ul style="list-style-type: none"> 'Ad27' will be displayed. Press the [ENT] key. | Ad27 |
| 5 | <ul style="list-style-type: none"> The 27th code value '0' is displayed. Press the [▲] key until the code value reaches '1'. | 0 |
| 6 | Press the [ENT] key. | 1 |
| 7 | The code value '1' will flash and then the 'Ad 27' code will be displayed. | Ad27 |

3.3.4 Initializing All Parameters

The following example demonstrates parameter initialization using the 93rd code (CF 93) of the Configuration group. Once executed, parameter initialization will delete all modified values for all codes and groups.

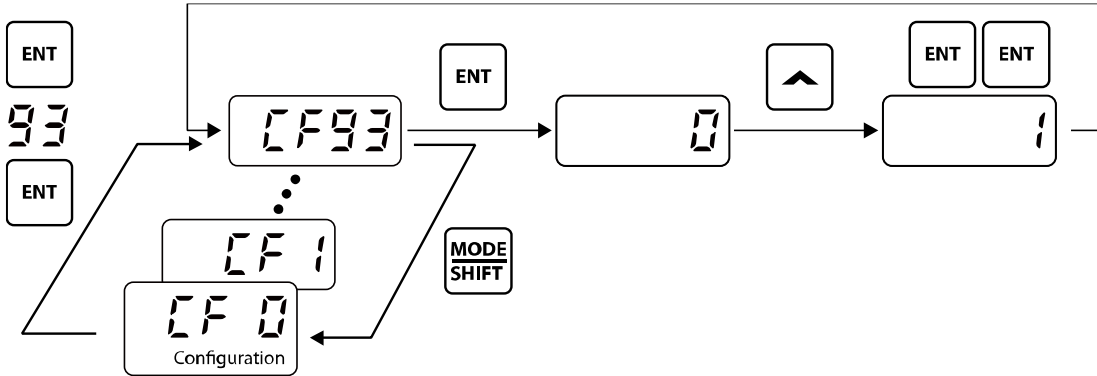

| Step | Instruction | Keypad Display |
|------|-----------------------------------------------------------------------------------------------------------------------------------------------------------------------------------------------------------------------------|----------------|
| 1 | <ul style="list-style-type: none"> The initial code of the Configuration (CF) group is displayed Press the [ENT] key. | |
| 2 | <ul style="list-style-type: none"> The current value ('1') will be displayed. Press the [▲] key until '3' is displayed. | |
| 3 | <ul style="list-style-type: none"> The code value '3' will be displayed. Press the [MODE] key. | |
| 4 | <ul style="list-style-type: none"> '0' will be displayed as the first digit and will be flashing. This indicates the first digit is ready to be modified. Press the [▲] key until '9' is displayed. | |
| 5 | <ul style="list-style-type: none"> '93' will be displayed. Press the [ENT] key. | |
| 6 | <ul style="list-style-type: none"> 'CF93' will be displayed. Press the [ENT] key. | |
| 7 | <ul style="list-style-type: none"> The parameter initialization will be in progress. Press the [▲] key | |
| 8 | Press the [ENT] key. After the code value flashes, press the [ENT] key again. | |
| 9 | The code number is displayed again after the initialization is complete. | |

3.3.5 Frequency Setting (Keypad) and Operation (via Terminal Input)

| Step | Instruction | Keypad Display |
|------|---------------------------------------------------------------------------------------------------------------------------------------------------------------------------------------------------------------------------------------------------------------------------------------------------------------------------------------------------------------------------------------------------------------------------|----------------|
| 1 | Turn on the inverter. | - |
| 2 | <ul style="list-style-type: none"> Ensure that '0.00' is displayed. Press the [ENT] key. | |
| 3 | <ul style="list-style-type: none"> '0', the last digit of '0.00', will be flashing. Press the [MODE] key three times. | |
| 4 | <ul style="list-style-type: none"> '00.00' will be displayed and its first digit will be flashing. Press the [▲] key. | |
| 5 | <ul style="list-style-type: none"> Ensure that '10.00' is displayed and then press the [ENT] key. When '10.00' starts flashing, press the [ENT] key. | |
| 6 | <ul style="list-style-type: none"> When the frequency reference is set to 10.00 Hz, '10.00' stops flashing. Turn ON the switch located between the P1 (FX) terminal and CM terminal. Refer to the Wiring Diagram below the table for information about the switch. | |
| 7 | <ul style="list-style-type: none"> The RUN indicator light next to the inverter display will flash, the FWD indicator will come on steady. The current acceleration frequency is displayed. When the frequency reference reaches (10 Hz), the display and indicator appear as shown in the image on the right. Turn OFF the switch located between the P1 (FX) terminal and CM terminal. | |
| 8 | <ul style="list-style-type: none"> The RUN indicator light next to the inverter display will flash again and the current deceleration frequency is displayed. When frequency reference reaches 0 Hz, the RUN and FWD indicator lights turn off, and the frequency reference (10.00 Hz) is displayed again. | |

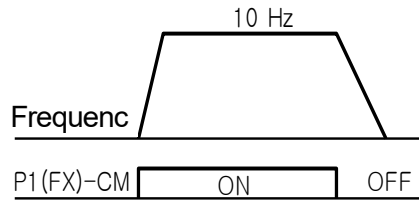
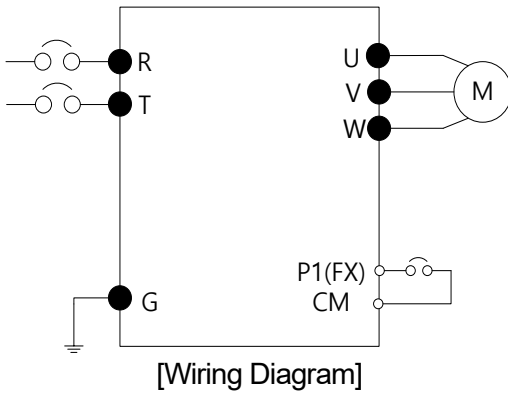

⚠ Caution

The instructions in the table are based on the factory default parameter settings. The inverter may not work correctly if the default parameter settings are changed after the inverter is purchased. In such cases, initialize all parameters to reset the values to factory default parameter settings before following the instructions in the table (refer to [6.166.16 Parameter Initialization](#) on page [136](#)).

3.3.6 Frequency Setting (External Potentiometer) and Operation (Terminal Input)

| Step | Instruction | Keypad Display |
|------|------------------------------------------------------------------------------------------------------------------------------------------------------|----------------|
| 1 | Turn on the inverter. | - |
| 2 | <ul style="list-style-type: none"> Ensure that '0.00' is displayed. Press the [▲] key four times. | 0.00 |
| 3 | <ul style="list-style-type: none"> Ensure that the code is moved to Frq (Frequency reference source). Press the [ENT] key. | Frq |
| 4 | <ul style="list-style-type: none"> The frequency reference source is set to 0 (Keypad). Press the [▲] key three times. | 0 |
| 5 | <ul style="list-style-type: none"> The frequency reference source is set to 3 (External Potentiometer). Press the [ENT] key. | 3 |

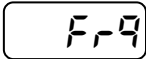
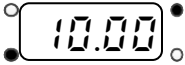
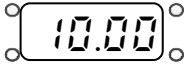
| Step | Instruction | Keypad Display |
|------|---------------------------------------------------------------------------------------------------------------------------------------------------------------------------------------------------------------------------------------------------------------------------------------------------------------------------------------------------------------------------------------------------------------------------------|-------------------------------------------------------------------------------------|
| 6 | <ul style="list-style-type: none"> • Press the [ENT] key while '3' flashes. • When the frequency reference source has been set to external potentiometer, the Frq code is displayed. • Press the [▼] key four times to return to monitor the frequency setting values. • Adjust the external potentiometer to increase or decrease the frequency reference to 10.00 Hz. |  |
| 7 | <ul style="list-style-type: none"> • The RUN indicator light next to the inverter display will flash, the FWD indicator will come on steady. The current acceleration frequency is displayed. • When the frequency reference reaches (10 Hz), the display and indicator appear as shown in the image on the right. • Turn OFF the switch located between the P1 (FX) terminal and CM terminal. |  |
| 8 | <ul style="list-style-type: none"> • The RUN indicator light next to the inverter display will flash again and the current deceleration frequency is displayed. • When frequency reference reaches 0 Hz, the RUN and FWD indicator lights turn off, and the frequency reference (10.00 Hz) is displayed again. |  |

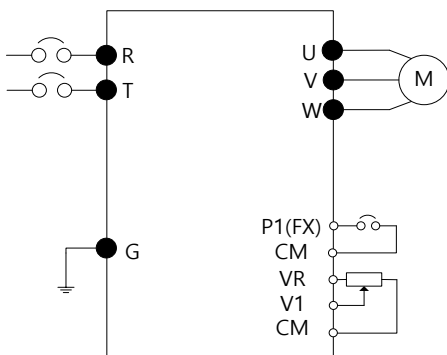

[Wiring Diagram]

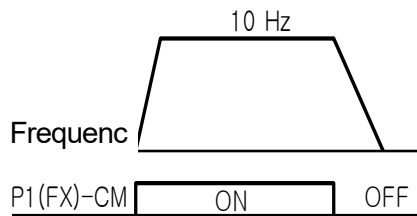

[Operation Pattern]

⚠ Caution

The instructions in the table are based on the factory default parameter settings. The inverter may not work correctly if the default parameter settings are changed after the inverter is purchased. In such cases, initialize all parameters to reset the values to factory default parameter settings before following the instructions in the table (refer to [6.16 Parameter](#)).

Initialization on page 136).

3.3.7 Frequency Setting (Built-in Potentiometer) and Operation (Keypad)

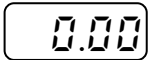
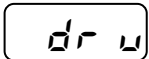
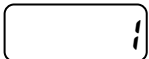
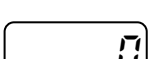
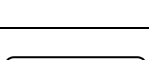
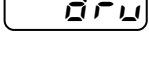
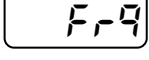
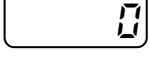
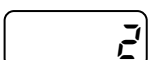
| Step | Instruction | Keypad Display |
|------|--------------------------------------------------------------------------------------------------------------------------------------------------------------------------------------------------------------------------------------------------------------------------------------------------------------------------------------------------|---------------------------------------------------------------------------------------|
| 1 | Turn on the inverter. | - |
| 2 | <ul style="list-style-type: none"> Ensure that the '0.00' is displayed. Press the [▲] key three times. |  |
| 3 | <ul style="list-style-type: none"> Ensure that the code is moved to drv (Command source). Press the [ENT] key. |  |
| 4 | <ul style="list-style-type: none"> The command source is set to 1 (Inverter terminal). Press the [▼] key. |  |
| 5 | <ul style="list-style-type: none"> Ensure that the code value '0' is displayed and then press the [ENT] key. Press the [ENT] key once again when '0' is flashing. |  |
| 6 | <ul style="list-style-type: none"> When the frequency setting is changed to the [RUN] key of the keypad, the drv code will be displayed. Press the [▲] key. |  |
| 7 | <ul style="list-style-type: none"> Ensure that the code is moved to Frq (Frequency reference source). Press the [ENT] key. |  |
| 8 | <ul style="list-style-type: none"> The frequency reference source is set to 0 (Keypad). Press the [▲] key 2 times. |  |
| 9 | <ul style="list-style-type: none"> Ensure that the frequency reference source is set to 2 (Built-in Potentiometer), and then press the [ENT] key. Press the [ENT] key once again while '2' is flashing. |  |
| 10 | <ul style="list-style-type: none"> When the frequency reference source has been set to keypad volume, the Frq code is displayed. Press the [▼] key four times to return to monitor the frequency setting values. Adjust the built-in potentiometer to increase or decrease the frequency reference to 10.00 Hz. |  |

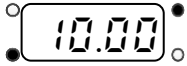
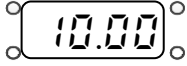
| Step | Instruction | Keypad Display |
|------|---------------------------------------------------------------------------------------------------------------------------------------------------------------------------------------------------------------------------------------------------------------------------------------------------------------------------------------------------------------------------------------------------------|-------------------------------------------------------------------------------------|
| 11 | <ul style="list-style-type: none"> Press the [RUN] key. The RUN indicator light next to the inverter display will flash, the FWD indicator will come on steady. The current acceleration frequency is displayed. When the frequency reference reaches (10 Hz), the display and indicator appear as shown in the image on the right. Press the [STOP/RST] key. |  |
| 12 | <ul style="list-style-type: none"> The RUN indicator light next to the inverter display will flash again and the current deceleration frequency is displayed. When frequency reference reaches 0 Hz, the RUN and FWD indicator lights turn off, and the frequency reference (10.00 Hz) is displayed again. |  |

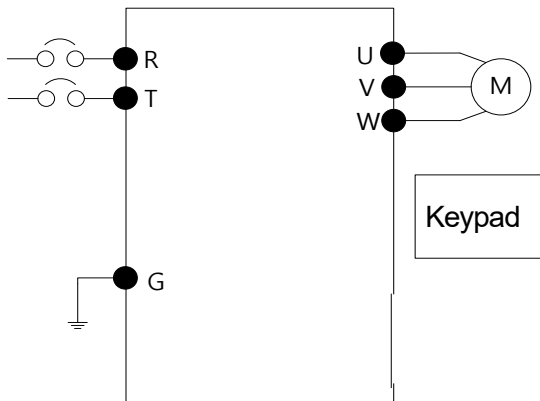

[Wiring Diagram]

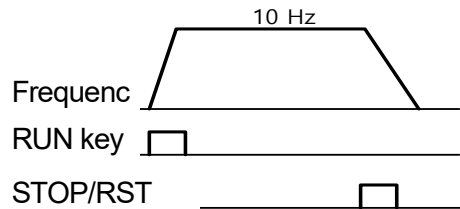

[Operation Pattern]

⚠ Caution

The instructions in the table are based on the factory default parameter settings. The inverter may not work correctly if the default parameter settings are changed after the inverter is purchased. In such cases, initialize all parameters to reset the values to factory default parameter settings before following the instructions in the table (refer to 6.166.16 Parameter Initialization on page 136).

3.4 Monitoring the Operation

3.4.1 Output Current Monitoring

The following example demonstrates how to monitor the output current in the Operation group using the keypad.

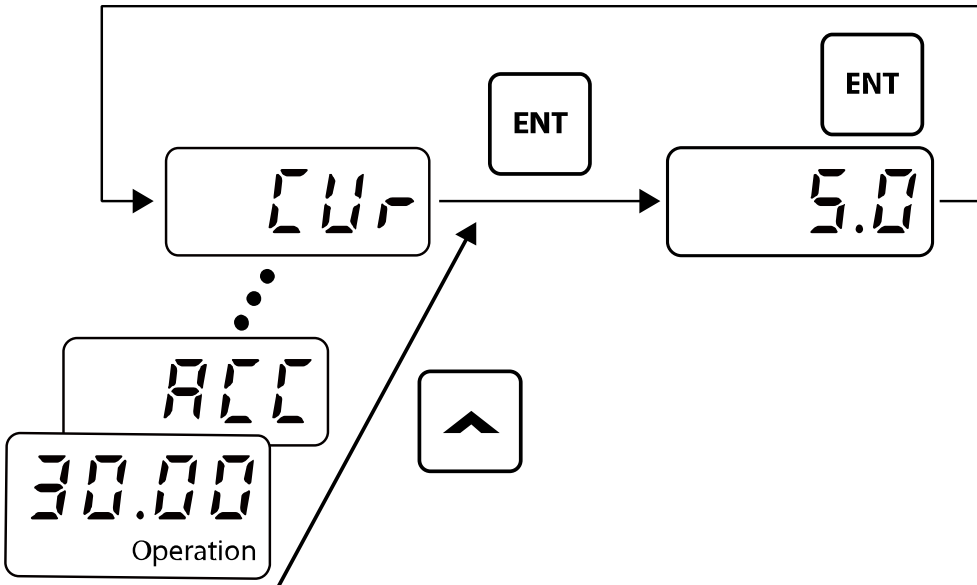

| Step | Instruction | Keypad Display |
|------|---------------------------------------------------------------------------------------------------------------------------------------------------------------------------------------------------------------------------------|----------------|
| 1 | <ul style="list-style-type: none"> Ensure that the first code of the Operation group is selected, and the code 30.00 (Command Frequency) is displayed. Press the [▲] or [▼] key until CUr is displayed. | |
| 2 | <ul style="list-style-type: none"> Ensure that the code is moved to CUr (Output current) for output current monitoring. Press the [ENT] key. | |
| 3 | <ul style="list-style-type: none"> The inverter output current (5.0 A) will be displayed Press the [ENT] key. | |
| 4 | <ul style="list-style-type: none"> The cursor will move to the left. Press the [MODE] key. | |

Note

You can use the dCL (DC link voltage monitor) and vOL (output voltage monitor) codes in the Operation group in exactly the same way as shown in the example above, to monitor each

function's relevant values.

3.4.2 Fault Trip Monitoring

The following example demonstrates how to monitor fault trip conditions in the Operation group using the keypad.

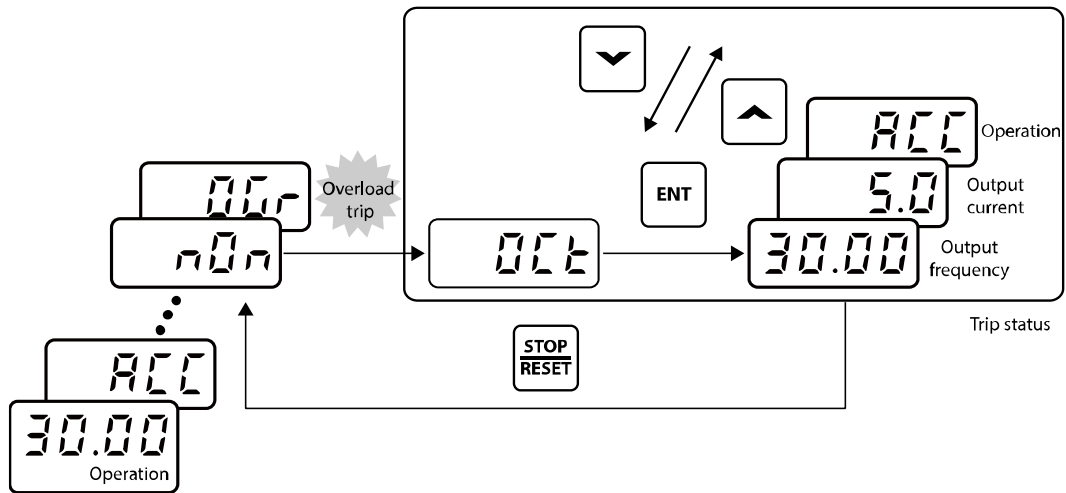

| Step | Instruction | Keypad Display |
|------|------------------------------------------------------------------------------------------------------------------------------------------------------------------------------------------------------------------------------|----------------|
| 1 | <ul style="list-style-type: none"> The OCt code is displayed when an over current trip fault has occurred. Press the [ENT] key, and then press the [▲] or [▼] key. | OCt |
| 2 | <ul style="list-style-type: none"> The operation frequency at the time of the fault (30.00 Hz) is displayed. Press the [▲] key. | 30.00 |
| 3 | <ul style="list-style-type: none"> The output current at the time of the fault (5.0 A) is displayed. Press the [▲] key. | 5.0 |
| 4 | <ul style="list-style-type: none"> The operation status at the time of the fault is displayed. ACC on the display indicates that the fault occurred during acceleration. Press the [STOP/RESET] key. | ACC |
| 5 | The fault condition is cleared and the nOn code is displayed. | nOn |

Note

- You can use the dCL (DC link voltage monitor) and vOL (output voltage monitor) codes in

the Operation group in exactly the same way as shown in the example above, to monitor each function's relevant values.

- If multiple fault trips occur at the same time, a maximum of 3 fault trip records can be retrieved as shown in the following example.

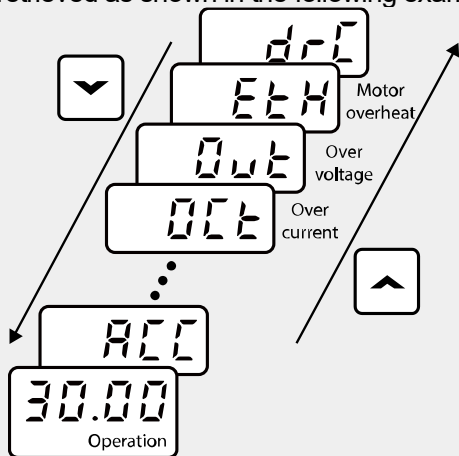

4 Control Block Diagram

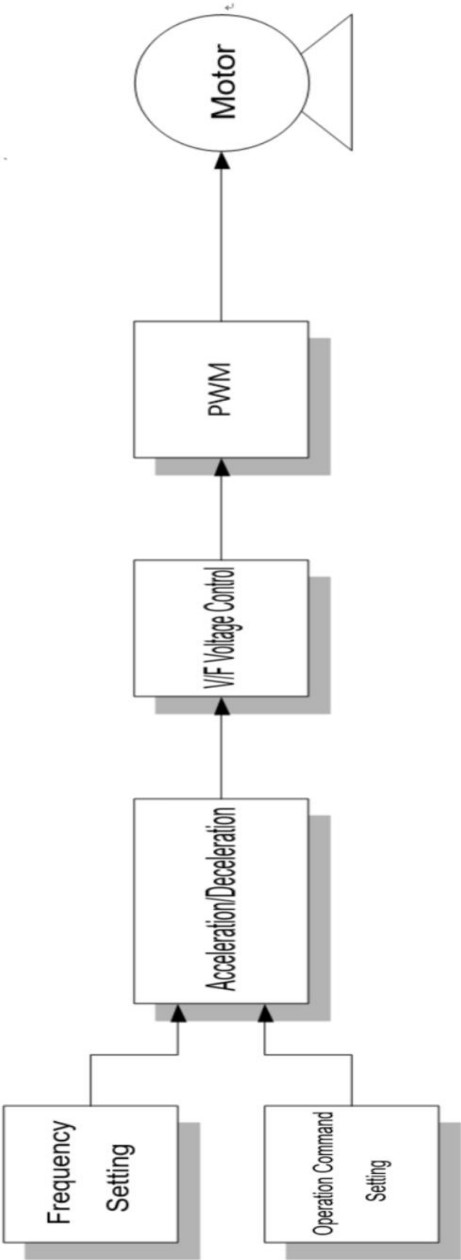

4.1 Setting Frequency

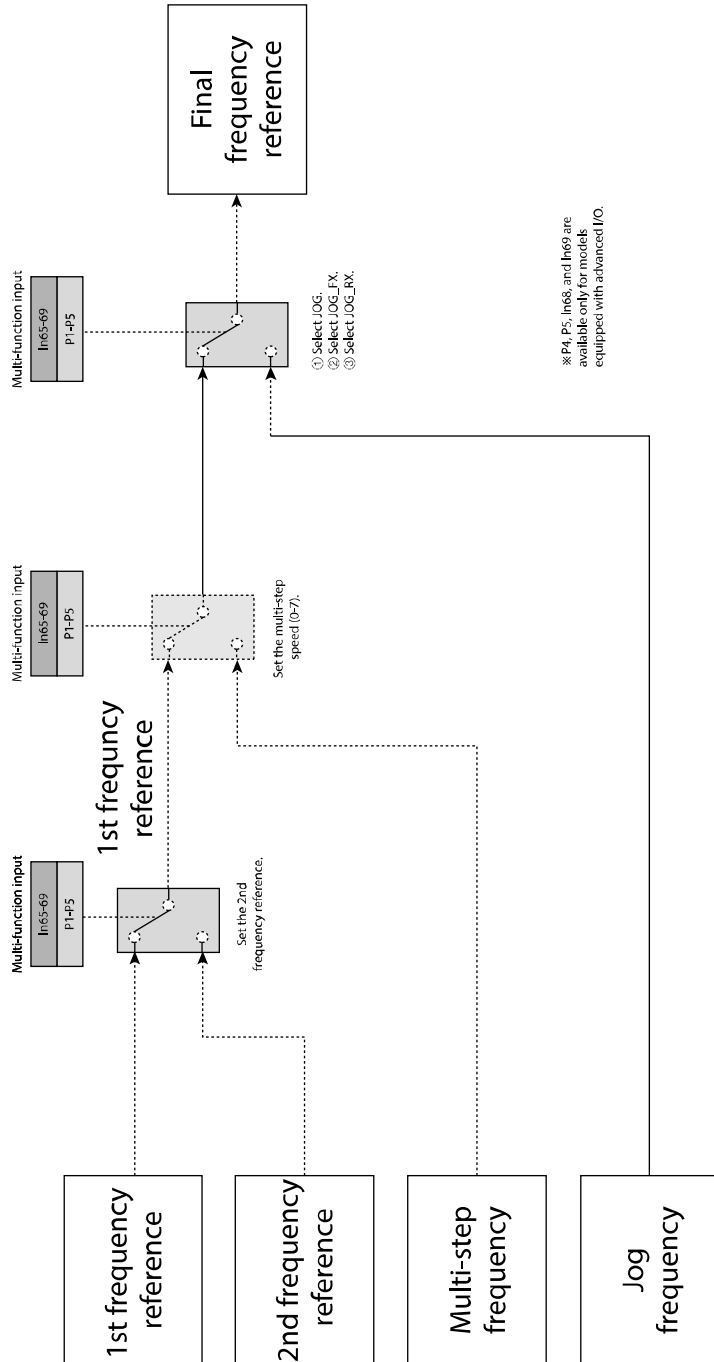

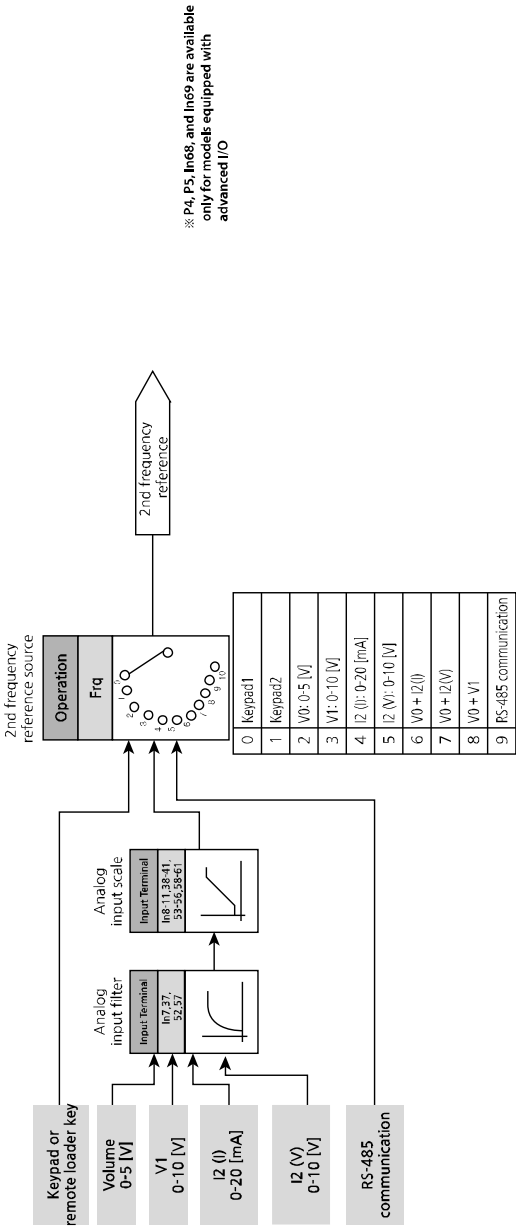
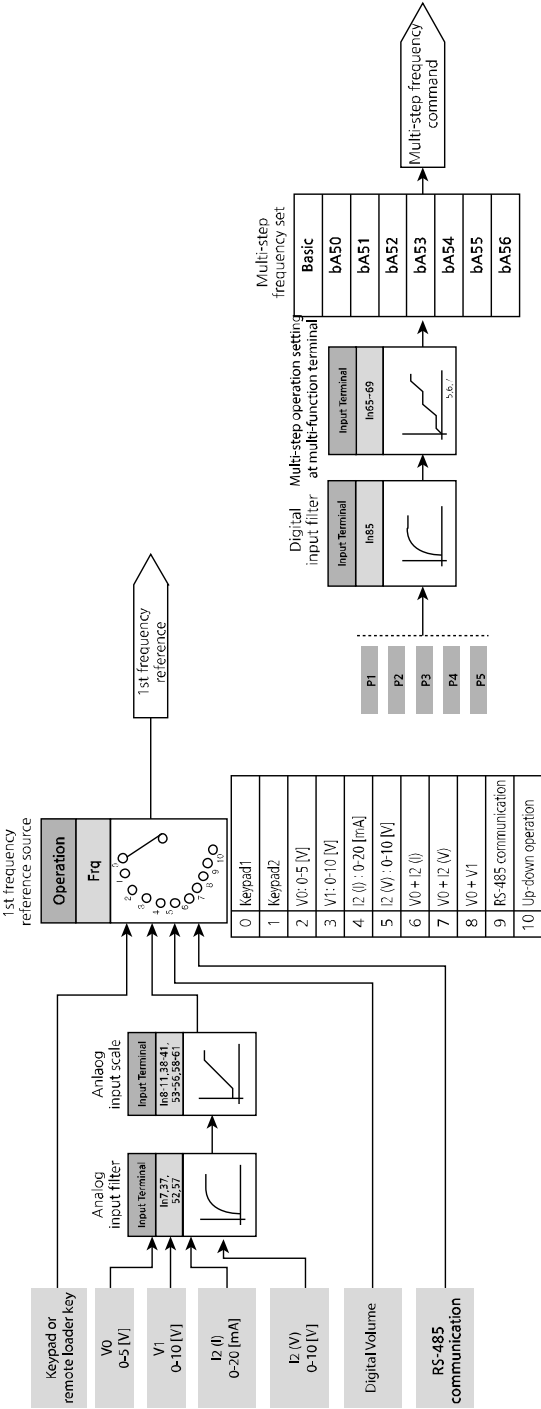

※ P4, P5, In68, and In69 are available only for models equipped with advanced I/O

4.2 Setting Run Command

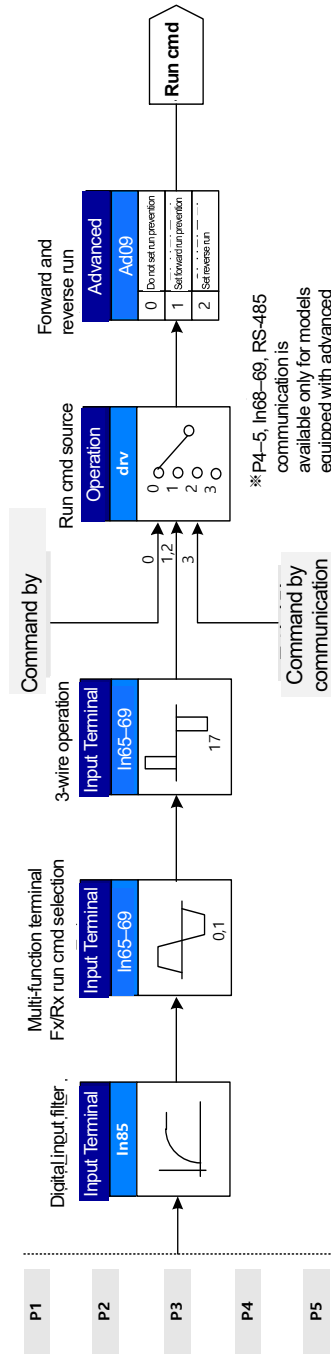

4.3 Controlling Acc/Dec and V/F Voltage

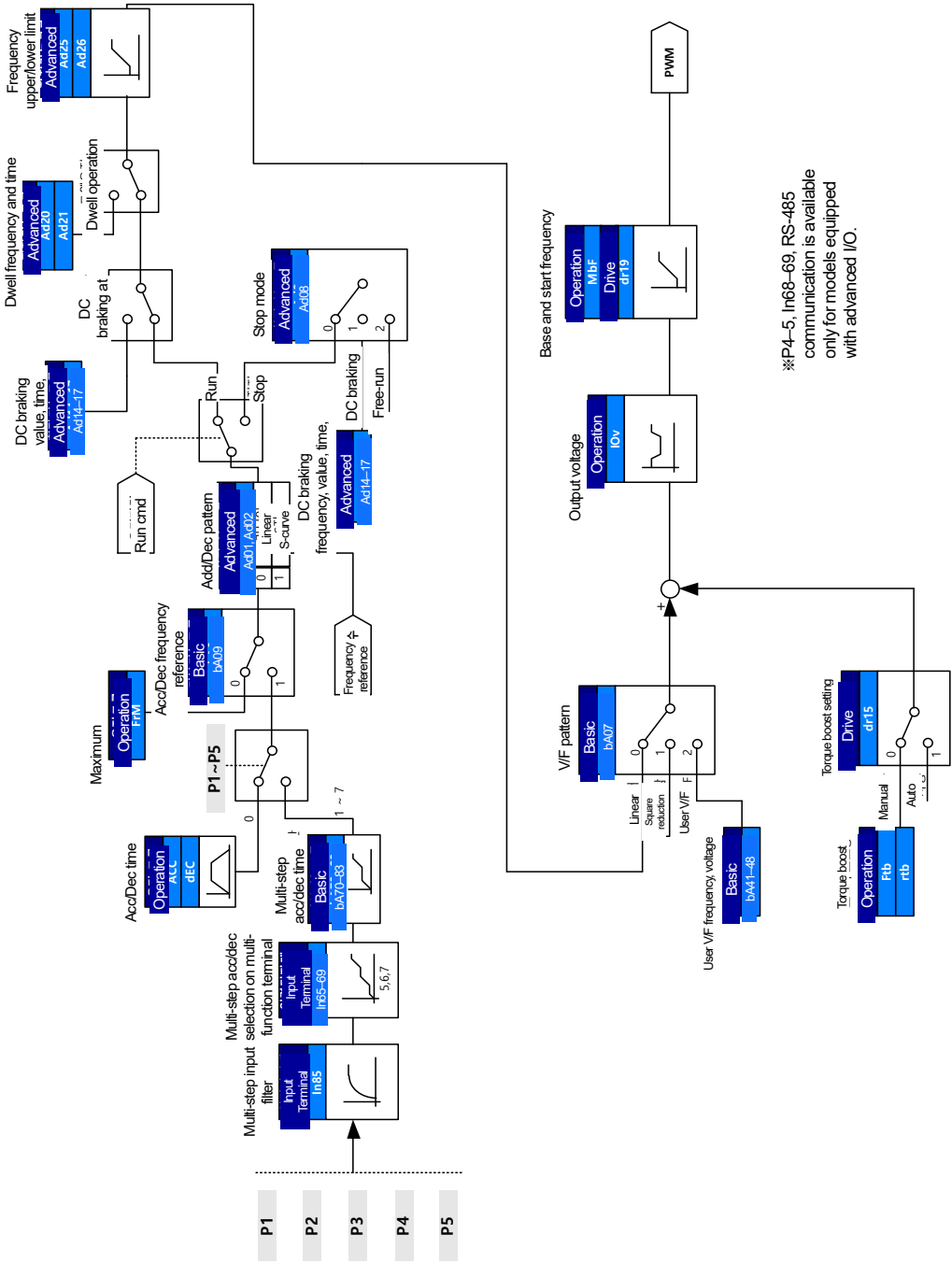

*P4-5, In68-69, RS-485 communication is available only for models equipped with advanced I/O.

5 Learning Basic Features

This chapter describes the basic features of the M100 inverter. Refer to the following sections to see detailed descriptions for each basic feature.

5.1 Setting Frequency Reference

The M100 inverter provides several methods to setup and modify a frequency reference for an operation. The keypad, analog inputs [e.g., voltage (V1) and current/voltage (I2)¹⁾ signals], or RS-485¹⁾ communication can be used.

| Group | Code | Name | Parameter Setting | | Setting Range | Initial Value | Unit | |
|-----------|------|----------------------------|-------------------|---------|---------------------------------------------------------------------------|---------------|------|---|
| Operation | Frq | Frequency reference source | 0 | Digital | Keypad digital frequency setting 1 | 0-11 | 0 | - |
| | | | 1 | | Keypad digital frequency setting 2 | | | |
| | | | 2 | Analog | V0 setting : 0 – 5 [V] | | | |
| | | | 3 | | V1 terminal setting at the terminal block : 0 –10 [V] | | | |
| | | | 4 | | I2 (I) terminal setting at the terminal block : 0–20 [mA] ¹⁾ | | | |
| | | | 5 | | I2 (V) terminal setting at the terminal block : 0–10 [V] ¹⁾ | | | |
| | | | 6 | | V0 setting + Terminal I2 (I) ¹⁾ | | | |
| | | | 7 | | V0 setting + Terminal I2 (V) ¹⁾ | | | |
| | | | 8 | | V0 setting + Terminal V1 | | | |
| | | | 9 | | RS-485 communication ¹⁾ | | | |
| | | | 11 | Analog | Terminal (V1) + Terminal I2 (I) ¹⁾ | | | |

1) Available only for models equipped with advanced I/O.

5.1.1 Keypad as the Source (Keypad-1 setting)

You can modify the frequency reference by using the keypad and apply changes by pressing the [ENT] key twice. To use the keypad as a frequency reference input source, go to the Frq (Frequency reference source) code in the Operation group and change the parameter value to 0. Input the frequency reference for an operation at the 0.00 (command frequency) code in the Operation group, and then press the [ENT] key twice.

| Group | Code | Name | Parameter Setting | Setting Range | Initial Value | Unit |
|-----------|------|----------------------------|-------------------|------------------|---------------|------|
| Operation | 0.00 | Command frequency | - | 0.00 – Max freq. | 0.00 | Hz |
| | Frq | Frequency reference source | 0 | 0 – 11 | 0 | - |

5.1.2 Keypad as the Source (Keypad-2 setting)

You can use the [▲] and [▼] keys to modify a frequency reference.

To use this as a second option, set the keypad as the source of the frequency by going to the Frq (Frequency reference source) code in the Operation group and changing the parameter value to 1. Press the [ENT] key and then press the [▲] or [▼] key to modify the frequency reference at the 0.00 (command frequency) code.

| Group | Code | Name | Parameter Setting | Setting Range | Initial Value | Unit |
|-----------|------|----------------------------|-------------------|------------------|---------------|------|
| Operation | 0.00 | Command frequency | - | 0.00 – Max freq. | 0.00 | Hz |
| | Frq | Frequency reference source | 1 | 0 ~ 11 | 0 | - |

5.1.3 Built-in Volume input (V0) 0 – 5 [V] as the Source

You can modify the frequency reference by using the built-in volume (V0) dial. Go to the Frq (Frequency reference source) code in the Operation group and change the parameter value to 2, and then rotate the built-in volume (V0) dial. You can monitor the parameter setting of the frequency reference at the 0.00 (command frequency) code in the Operation group.

| Group | Code | Name | Parameter Setting | Setting Range | Initial Value | Unit |
|-----------|------|-------------------|-------------------|-----------------|---------------|------|
| Operation | 0.00 | Command frequency | - | 0.00 –Max freq. | 0.00 | Hz |

| Group | Code | Name | Parameter Setting | Setting Range | Initial Value | Unit |
|---------------------|------|---------------------------------------------------------|-------------------|------------------------------|---------------|------|
| | Frq | Frequency reference source | 2 | 0–11 | 0 | - |
| In (Input Terminal) | 37 | V0 input filter time constant | 10 | 0 – 9999 | 10 | - |
| | 38 | V0 input minimum voltage | - | 0.00 – V0 input max voltage | 0.00 | V |
| | 39 | Frequency corresponding to the V0 input minimum voltage | - | 0.00 –Max frq. | 0.00 | Hz |
| | 40 | V0 input maximum voltage | - | V0 input min. voltage – 5.00 | 5.00 | V |
| | 41 | Frequency corresponding to the V0 input maximum voltage | - | 0.00 –Max frq. | 60.00 | Hz |

5.1.4 V1 Terminal as the Source

You can modify a frequency reference by setting the voltage inputs when using the V1 terminal or connecting the VR terminal to the V1 terminal.

| Group | Code | Name | Parameter Setting | Setting Range | Initial Value | Unit |
|---------------------|------|---------------------------------------------------------|-------------------|-------------------------------|---------------|------|
| Operation | 0.00 | Command frequency | - | 0.00 –Max frq. | 0.00 | Hz |
| | Frq | Frequency reference source | 3 | 0 – 11 | 0 | - |
| In (Input Terminal) | 07 | V1 input filter time constant | 10 | 0–9999 | 10 | - |
| | 08 | V1 input minimum voltage | - | 0.00– V1 input max voltage | 0.00 | V |
| | 09 | Frequency corresponding to the V1 input minimum voltage | - | 0.00 –Max frq. | 0.00 | Hz |
| | 10 | V1 input maximum voltage | - | V1 input min. voltage – 10.00 | 10.00 | V |
| | 11 | Frequency corresponding to the V1 input maximum voltage | - | 0.00 –Max frq. | 60.00 | Hz |

Go to the Frq code in the Operation group and change the parameter value to 3.

You can monitor the parameter setting of the frequency reference at the 0.00 (command frequency) code in the Operation group.

Load the 0 V-10 V signal between the V1 and CM terminals.

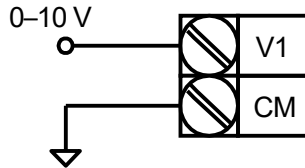

When the 0-10 V voltage is loaded from an external source

In 08 -11: Sets the input range and corresponding frequency for the forward (+) input voltage (0 V–10 V) loaded to the V1 terminal.

Example) When the minimum forward (+) input voltage loaded to the V1 terminal is 2 V while the frequency for the 2 V input is set to 10 Hz, and when the maximum input voltage loaded to the V1 terminal is 8 V while the operation frequency is set to 50 Hz, the input range is set as below:

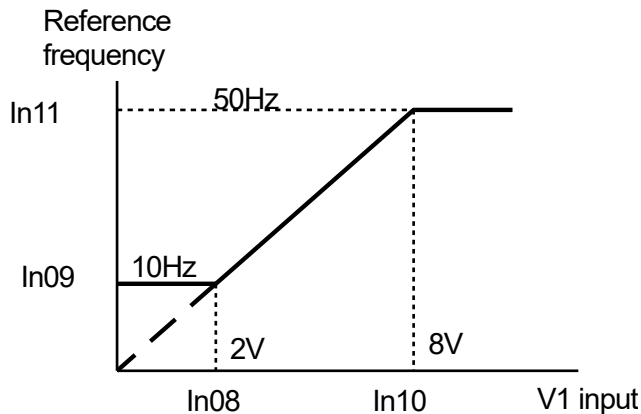

You can connect the terminal wiring as shown below. Refer to the In 07 –11 features.

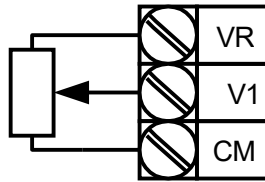

Connecting volume resistor to the terminal block

5.1.5 Input Current (Terminal I2) as the Source

You can input the current to the control terminal block and set the command frequency by changing the SW2 switch to I.¹⁾ Go to the Frq (Frequency reference source) code in the Operation group and change the parameter value to 4, and then input the 0 – 20 mA current to the I2 and CM terminals.

| Group | Code | Name | Parameter Setting | Setting Range | Initial Value | Unit |
|---------------------|------------------|--------------------------------------------------------|-------------------|------------------------------|---------------|------|
| Operation | 0.00 | Command frequency | - | 0.00 – Max freq. | 0.00 | Hz |
| | Frq | Frequency reference source | 4 ¹⁾ | 0 – 11 | 0 | - |
| In (Input Terminal) | 52 ¹⁾ | I input filter time constant | 10 | 0 – 9999 | 10 | - |
| | 53 ¹⁾ | I input minimum current | - | 0.00 – I input max current | 4.00 | mA |
| | 54 ¹⁾ | Frequency corresponding to the I input minimum current | - | 0.00 – Max freq. | 0.00 | Hz |
| | 55 ¹⁾ | I input maximum current | - | I input min. current – 20.00 | 20.00 | mA |
| | 56 ¹⁾ | Frequency corresponding to the I input maximum current | - | 0.00 – Max freq. | 60.00 | Hz |

1) Available only for models equipped with advanced I/O.

5.1.6 Input Voltage (Terminal I2) as the Source

You can input the voltage to the control terminal block and set the command frequency by changing the SW2 switch to V¹⁾. Go to the Frq (Frequency reference source) code in the Operation group and change the parameter value to 5, and then input the 0–10 V voltage to the I2 and CM terminals.

| Group | Code | Name | Parameter Setting | Setting Range | Initial Value | Unit |
|---------------------|------------------|--------------------------------------------------------|-------------------|------------------------------|---------------|------|
| Operation | 0.00 | Command frequency | - | 0.00 – Max frq. | 0.00 | Hz |
| | Frq | Frequency reference source | 5 ¹⁾ | 0 – 11 | 0 | - |
| In (Input Terminal) | 57 ¹⁾ | V input filter time constant | 10 | 0 – 9999 | 10 | - |
| | 58 ¹⁾ | V input minimum voltage | - | 0.00 – V input max. voltage | 0.00 | V |
| | 59 ¹⁾ | Frequency corresponding to the V input minimum voltage | - | 0.00 – Max frq. | 0.00 | Hz |
| | 60 ¹⁾ | V input maximum voltage | - | V input min. voltage – 10.00 | 10.00 | V |
| | 61 ¹⁾ | Frequency corresponding to the V input maximum voltage | - | 0.00 – Max frq. | 60.00 | Hz |

1) Available only for models equipped with advanced I/O.

5.1.7 Frequency Reference Setting via Built-in Volume (V0) and I2 Terminal

You can specify the current inputs for the built-in volume (V0) and I2 terminal as the main reference and auxiliary reference respectively and enable the override feature. ¹⁾ Change the SW2 switch of the control terminal block and go to the Frq (Frequency reference source) code in the Operation group and change the parameter value to 6.

| Group | Code | Name | Parameter Setting | Setting Range | Initial Value | Unit |
|-----------|------|----------------------------|-------------------|-----------------|---------------|------|
| Operation | 0.00 | Command frequency | - | 0.00 – Max frq. | 0.00 | Hz |
| | Frq | Frequency reference source | 6 ¹⁾ | 0 – 11 | 0 | - |

1) Available only for models equipped with advanced I/O.

Override is a feature for entering the main reference value and the auxiliary reference value simultaneously and applying the total value as a frequency reference. You can receive a quick response via the main reference and accurately control via the auxiliary reference,

The built-in volume (V0) range is 0 – 5 V for the auxiliary reference and 0 –20 mA for the main reference to use the override feature. You can set the main reference and auxiliary reference values according to your operation condition.

Please refer to the following override operation settings.

| Group | Code | Name | Parameter Setting | Setting Range |
|---------------------|--------------------------------------------------------|---------------------------------------------------------|-------------------|---------------|
| In (Input Terminal) | 37 | V0 input filter time constant | 10 | - |
| | 38 | V0 input minimum voltage | 0.00 | V |
| | 39 | Frequency corresponding to the V0 input minimum voltage | 0.00 | Hz |
| | 40 | V0 input maximum voltage | 5.00 | V |
| | 41 | Frequency corresponding to the V0 input maximum voltage | 5.00 | Hz |
| | 52 ¹⁾ | I input filter time constant | 10 | - |
| | 53 ¹⁾ | I input minimum current | 4.00 | mA |
| | 54 ¹⁾ | Frequency corresponding to the I input minimum current | 0.00 | Hz |
| | 55 ¹⁾ | I input maximum current | 20.00 | mA |
| 56 ¹⁾ | Frequency corresponding to the I input maximum current | 60.00 | Hz | |

1) Available only for models equipped with advanced I/O.

When the volume voltage is 2.5 V (2.5 Hz) and 12 mA (30 Hz) is supplied to the I2 terminal, the inverter output frequency becomes 32.5 Hz.

5.1.8 Frequency Reference Setting via Built-in Volume (V0) and I2 Terminal

You can specify the voltage inputs for the built-in volume (V0) and I2 terminal as the main reference and auxiliary reference respectively and enable the override feature. ¹⁾ Change the SW2 switch of the control terminal block and go to the Frq (Frequency reference source) code in the Operation group and change the parameter value to 7.

| Group | Code | Name | Parameter Setting | Setting Range | Initial Value | Unit |
|-----------|------|----------------------------|-------------------|----------------|---------------|------|
| Operation | 0.00 | Command frequency | - | 0.00 –Max frq. | 0.00 | Hz |
| | Frq | Frequency reference source | 7 ¹⁾ | 0 – 11 | 0 | - |

1) Available only for models equipped with advanced I/O.

| Group | Code | Name | Parameter Setting | Unit |
|---------------------|------|---------------------------------------------------------|-------------------|------|
| In (Input Terminal) | 37 | V0 input filter time constant | 10 | - |
| | 38 | V0 input minimum voltage | 0.00 | V |
| | 39 | Frequency corresponding to the V0 input minimum voltage | 0.00 | Hz |

| Group | Code | Name | Parameter Setting | Unit |
|-------|------------------|---------------------------------------------------------|-------------------|------|
| | 40 | V0 input maximum voltage | 5.00 | V |
| | 41 | Frequency corresponding to the V0 input maximum voltage | 5.00 | Hz |
| | 57 ¹⁾ | V input filter time constant | 10 | - |
| | 58 ¹⁾ | V input minimum voltage | 0.00 | V |
| | 59 ¹⁾ | Frequency corresponding to the V input minimum voltage | 0.00 | Hz |
| | 60 ¹⁾ | V input maximum voltage | 10.00 | V |
| | 61 ¹⁾ | Frequency corresponding to the V input maximum voltage | 60.00 | Hz |

1) Available only for models equipped with advanced I/O.

When the volume voltage is 2.5 V (2.5 Hz) and 5 V (30 Hz) is supplied to the I2 terminal, the inverter output frequency becomes 32.5 Hz.

5.1.9 Frequency Reference Setting via Built-in Volume (V0) and V1 Terminal

You can specify the voltage input for the built-in volume (V0) and V1 terminal as the main reference and auxiliary reference respectively and enable the override feature, Go to the Frq (Frequency reference source) code in the Operation group and change the parameter setting to 8.

| Group | Code | Name | Parameter Setting | Setting Range | Initial Value | Unit |
|-----------|------|----------------------------|-------------------|-----------------|---------------|------|
| Operation | 0.00 | Command frequency | - | 0.00 – Max frq. | 0.00 | Hz |
| | Frq | Frequency reference source | 8 | 0 ~ 11 | 0 | - |

| Group | Code | Name | Parameter Setting | Unit |
|---------------------|------|---------------------------------------------------------|-------------------|------|
| In (Input Terminal) | 37 | V0 input filter time constant | 10 | - |
| | 38 | V0 input minimum voltage | 0.00 | V |
| | 39 | Frequency corresponding to the V0 input minimum voltage | 0.00 | Hz |
| | 40 | V0 input maximum voltage | 5.00 | V |
| | 41 | Frequency corresponding to the V0 input maximum voltage | 5.00 | Hz |
| | 07 | V1 input filter time constant | 10 | - |
| | 08 | V1 input minimum voltage | 0.00 | V |
| | 09 | Frequency corresponding to the V1 input | 0.00 | Hz |

| Group | Code | Name | Parameter Setting | Unit |
|-------|------|---------------------------------------------------------|-------------------|------|
| | | minimum voltage | | |
| | 10 | V1 input maximum voltage | 10.00 | V |
| | 11 | Frequency corresponding to the V1 input maximum voltage | 60.00 | Hz |

When the V0 voltage is 2.5 V (2.5 Hz) and 5 V (30 Hz) is supplied to the V1 terminal, the inverter output frequency becomes 32.5 Hz.

5.1.10 Frequency Reference Setting via V1 Terminal and I2 Terminal

You can specify the voltage input for the V1 terminal and I2 terminal as the main reference and auxiliary reference respectively and enable the override feature. Go to the Frq (Frequency reference source) code in the Operation group and change the parameter setting to 11.

| Group | Code | Name | Parameter Setting | Setting Range | Initial Value | Unit |
|-----------|------|----------------------------|-------------------|------------------|---------------|------|
| Operation | 0.00 | Command frequency | - | 0.00 – Max freq. | 0.00 | Hz |
| | Frq | Frequency reference source | 11 | 0 ~ 11 | 0 | - |

| Group | Code | Name | Parameter Setting | Unit |
|---------------------|------------------|---------------------------------------------------------|-------------------|------|
| In (Input Terminal) | 07 | V1 input filter time constant | 10 | - |
| | 08 | V1 input minimum voltage | 0.00 | V |
| | 09 | Frequency corresponding to the V1 input minimum voltage | 0.00 | Hz |
| | 10 | V1 input maximum voltage | 10.00 | V |
| | 11 | Frequency corresponding to the V1 input maximum voltage | 5.00 | Hz |
| | 52 ¹⁾ | I2 input filter time constant | 10 | - |
| | 53 ¹⁾ | I2 input minimum current | 4.00 | mA |
| | 54 ¹⁾ | Frequency corresponding to the I2 input minimum current | 0.00 | Hz |
| | 55 ¹⁾ | I2 input maximum current | 20.00 | mA |
| | 56 ¹⁾ | Frequency corresponding to the I2 input maximum current | 60.00 | Hz |

When the V1 voltage is 2.5 V (2.5 Hz) and 12mA (30 Hz) is supplied to the I2 terminal, the inverter output frequency becomes 32.5 Hz.

5.1.11 Frequency Reference Setting via RS-485 Communication

You can control the inverter with upper-level controllers, such as PCs or PLCs, via RS-485 communication. Go to the Frq (Frequency reference source) code in the Operation group and change the parameter setting to 9. This feature is available only for models equipped with advanced I/O.

| Group | Code | Name | Parameter Setting | Setting Range | Initial Value | Unit |
|-------------------------------------|------|--------------------------------|-------------------|------------------|---------------|------|
| Operation | 0.00 | Command frequency | - | 0.00 – Max freq. | 0.00 | Hz |
| | Frq | Frequency reference source | 9 ¹⁾ | 0 – 11 | 0 | - |
| CM (Communication) ¹⁾ | 01 | Inverter station | - | 1 – 250 | 1 | - |
| | 02 | Communication protocol setting | - | 0 – 1 | 0 | - |
| | 03 | Communication speed | - | 0 – 5 | 3 | - |

1) Available only for models equipped with advanced I/O.

※ For more information about RS-485 communication features, refer to 8 RS-485 Communication Features on page 171.

5.1.12 Frequency Reference Setting via Digital Volume (Up-Down)

| Group | Code | Name | Parameter Setting | Setting Range | Initial Value | Unit |
|-----------|------|----------------------------|-------------------|------------------|---------------|------|
| Operation | 0.00 | Command frequency | - | 0.00 – Max freq. | 0.00 | Hz |
| | Frq | Frequency reference source | 10 | 0 – 10 | 0 | - |

You can modify the command frequency by using the multi-function input terminal. Go to the Frq (Frequency reference source) code in the Operation group and change the parameter setting to 10.

Related code: In65-69, Ad64-67

※ For more information, refer to 6.3_Up-down Operation on page 112.

5.2 Holding Analog Command Frequency

Hold the command frequency by using multi-function input terminals.

| Group | Code | Name | Parameter Setting | Setting Range | Initial Value | Unit |
|---------------------|-------------------|---------------------------------------------------|-------------------|---------------|---------------|------|
| Operation | Frq ¹⁾ | Frequency reference source | 2 – 8 | 0 – 11 | 0 | - |
| In (Input Terminal) | 65 | Multi-function input terminal P1 function setting | - | 0 – 27 | 0 | - |
| | 66 | Multi-function input terminal P2 function setting | - | | 1 | |
| | 67 | Multi-function input terminal P3 function setting | - | | 2 | |
| | 68 ²⁾ | Multi-function input terminal P4 function setting | - | | 3 | |
| | 69 ²⁾ | Multi-function input terminal P5 function setting | 23 | | 4 | |

- 1) You can only set 2, 3, and 8 for the Frq (Frequency reference source) parameter setting for models equipped with standard I/O. For models equipped with advanced I/O, you can set 2–8.
- 2) For models equipped with standard I/O, you can set the parameter by In65–67 (Multi-function input terminal P1–P3). You can use up to 3 multi-function input terminals for models equipped with standard I/O. If you must use more than 3 multi-function input terminals, use models equipped with advanced I/O.

You can hold the command frequency by using multi-function input terminals when the parameter setting is 2–8 at the Frq (Frequency reference source) code in the Operation group. Select a terminal to be used as an analog command frequency hold signal from P1–P3 for standard I/O models or from P1–P5 for advanced I/O models, and then change the parameter setting to 23 at the corresponding code (standard I/O model: In65–67, advanced I/O model: In65–69).

It will operate as shown below when using the P5 terminal (In 69).

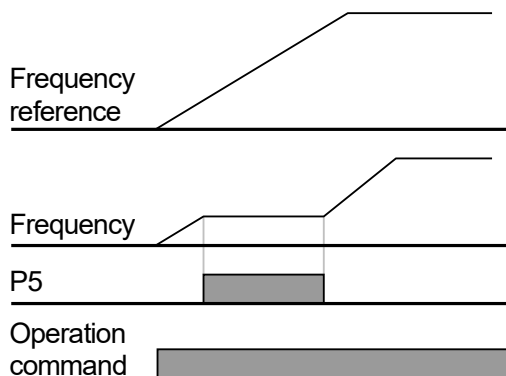

5.3 Setting Multi-step Frequency

| Group | Code | Name | Parameter Setting | Setting Range | Initial Value | Unit |
|---------------------|------------------|---------------------------------------------------|-------------------|------------------|---------------|------|
| Operation | 0.00 | Command frequency | 5.0 | 0.00 – Max freq. | 0.00 | Hz |
| | Frq | Frequency reference source | 0 | 0–11 | 0 | - |
| In (Input Terminal) | 67 | Multi-function input terminal P3 function setting | 5 | 0–27 | 2 | - |
| | 68 ¹⁾ | Multi-function input terminal P4 function setting | 6 | | 3 | - |
| | 69 ¹⁾ | Multi-function input terminal P5 function setting | 7 | | 4 | - |
| bA (Basic) | 50 | Multi-step frequency 1 | - | 0.00–Max freq. | 10.00 | Hz |
| | 51 | Multi-step frequency 2 | - | | 20.00 | |
| | 52 | Multi-step frequency 3 | - | | 30.00 | |
| | 53 | Multi-step frequency 4 | - | | 30.00 | |
| | 54 | Multi-step frequency 5 | - | | 25.00 | |
| | 55 | Multi-step frequency 6 | - | | 20.00 | |
| | 56 | Multi-step frequency 7 | - | | 15.00 | |

1) For models equipped with standard I/O, you can set the parameter by In65-67 (Multi-function input terminal P1-P3). You can use up to 3 multi-function input terminals for models equipped with standard I/O. If you must use more than 3 multi-function input terminals, use models equipped with advanced I/O.

| Code | Description | | | | | | | | | | | | | | | | | | | | | | | | | | | | | | | | | | | | | | | | | | | | | |
|-----------------------|-------------------------------------------------------------------------------------------------------------------------------------------------------------------------------------------------------------------------------------------------------------------------------------------------------------------------------------------------------------------------------------------------------------------------------------------------------------------------------------------------------------------------------------------------------------------------------------------------------------------------------------------------------------------------------------------------------------------------------------------------------------------------------------------------------------------------------------------------------------------------------------------------------------------------------------------------------------------------------------------------------------------------------------------------------------------------------------------------------------------------------------------------------------------------------------------------|-------|-------|-------|----|----|---|---|---|---|---|---|---|---|---|-------|---|---|---|-------|---|---|---|---|-------|-------|---|---|-------|---|---|---|---|-------|---|-------|---|---|-------|-------|---|---|---|-------|-------|-------|
| bA50–56 | Configure multi-step frequency 1–7 at the bA50–56 codes. | | | | | | | | | | | | | | | | | | | | | | | | | | | | | | | | | | | | | | | | | | | | | |
| In65–69 ¹⁾ | <p>Set a terminal to use as the multi-step frequency reference among P1 – P5¹⁾. When you input the multi-step frequency reference via the P3 – P5 terminals¹⁾, set the parameter to 5–7 respectively at the In67–In69 codes in the Input Terminal group.</p> <p>Step 0 uses the frequency reference source set with the Frq and 0.00 frequency codes in the Operation group.</p> <table border="1"> <thead> <tr> <th>Speed</th> <th>Fx/Rx</th> <th>P5</th> <th>P4</th> <th>P3</th> </tr> </thead> <tbody> <tr> <td>0</td> <td>✓</td> <td>-</td> <td>-</td> <td>-</td> </tr> <tr> <td>1</td> <td>✓</td> <td>-</td> <td>-</td> <td>✓(+1)</td> </tr> <tr> <td>2</td> <td>✓</td> <td>-</td> <td>✓(+2)</td> <td>-</td> </tr> <tr> <td>3</td> <td>✓</td> <td>-</td> <td>✓(+2)</td> <td>✓(+1)</td> </tr> <tr> <td>4</td> <td>✓</td> <td>✓(+4)</td> <td>-</td> <td>-</td> </tr> <tr> <td>5</td> <td>✓</td> <td>✓(+4)</td> <td>-</td> <td>✓(+1)</td> </tr> <tr> <td>6</td> <td>✓</td> <td>✓(+4)</td> <td>✓(+2)</td> <td>-</td> </tr> <tr> <td>7</td> <td>✓</td> <td>✓(+4)</td> <td>✓(+2)</td> <td>✓(+1)</td> </tr> </tbody> </table> <p>[An example of a multi-step operation]</p> | Speed | Fx/Rx | P5 | P4 | P3 | 0 | ✓ | - | - | - | 1 | ✓ | - | - | ✓(+1) | 2 | ✓ | - | ✓(+2) | - | 3 | ✓ | - | ✓(+2) | ✓(+1) | 4 | ✓ | ✓(+4) | - | - | 5 | ✓ | ✓(+4) | - | ✓(+1) | 6 | ✓ | ✓(+4) | ✓(+2) | - | 7 | ✓ | ✓(+4) | ✓(+2) | ✓(+1) |
| Speed | Fx/Rx | P5 | P4 | P3 | | | | | | | | | | | | | | | | | | | | | | | | | | | | | | | | | | | | | | | | | | |
| 0 | ✓ | - | - | - | | | | | | | | | | | | | | | | | | | | | | | | | | | | | | | | | | | | | | | | | | |
| 1 | ✓ | - | - | ✓(+1) | | | | | | | | | | | | | | | | | | | | | | | | | | | | | | | | | | | | | | | | | | |
| 2 | ✓ | - | ✓(+2) | - | | | | | | | | | | | | | | | | | | | | | | | | | | | | | | | | | | | | | | | | | | |
| 3 | ✓ | - | ✓(+2) | ✓(+1) | | | | | | | | | | | | | | | | | | | | | | | | | | | | | | | | | | | | | | | | | | |
| 4 | ✓ | ✓(+4) | - | - | | | | | | | | | | | | | | | | | | | | | | | | | | | | | | | | | | | | | | | | | | |
| 5 | ✓ | ✓(+4) | - | ✓(+1) | | | | | | | | | | | | | | | | | | | | | | | | | | | | | | | | | | | | | | | | | | |
| 6 | ✓ | ✓(+4) | ✓(+2) | - | | | | | | | | | | | | | | | | | | | | | | | | | | | | | | | | | | | | | | | | | | |
| 7 | ✓ | ✓(+4) | ✓(+2) | ✓(+1) | | | | | | | | | | | | | | | | | | | | | | | | | | | | | | | | | | | | | | | | | | |

1) For models equipped with standard I/O, you can set the parameter by In65-67 (Multi-function input terminal P1-P3). You can use up to 3 multi-function input terminals for models equipped with standard I/O. If you must use more than 3 multi-function input terminals, use models equipped with advanced I/O.

5.4 Command Source Configuration

Various devices can be selected as command input devices for the M100 inverter. Input devices available to select include keypad, multi-function input terminal, and RS-485 communication.

| Group | Code | Name | Parameter Setting | | Setting Range | Initial Value | Unit | |
|-----------|------|----------------|-------------------|-------------------------------------------------|---------------|---------------|------|----------------------------------------------------------------|
| Operation | drv | Command source | 0 | Operation by keypad, the Run and Stop keys | 0-3 | 1 | - | |
| | | | 1 | Terminal block operation | | | | FX: Forward operation command RX: Reverse operation command |
| | | | 2 | | | | | FX: Run, stop RX: Reversed motor direction |
| | | | 3 | Operation by RS-485 communication ¹⁾ | | | | |

1) Available only for models equipped with advanced I/O.

5.4.1 The Keypad as a Command Input Device

The keypad can be selected as a command input device to send command signals to the inverter. This is configured by setting the drv code to 0 in the Operation group. Press the [RUN] or [STOP] keys on the keypad to start or stop an operation.

| Group | Code | Name | Parameter Setting | Setting Range | Initial Value | Unit |
|------------|------|--------------------------------------------------|-------------------|---------------|---------------|------|
| Operation | drv | Command source | 0 | 0-3 | 1 | - |
| dr (Drive) | 20 | Motor rotation direction selection ¹⁾ | - | F, r | F | - |

1) The rotation direction command by the dr20 setting is applied only when drv(Command source) is set to 0. You can still display and set the dr20 setting when drv(Command source) is set to other than 0.

You can press the [RUN] key to start an operation, and the [STOP/RST] key to decelerate the motor and end the operation.

When you use the keypad as a command input device, you can set the motor rotation direction at the dr20 code.

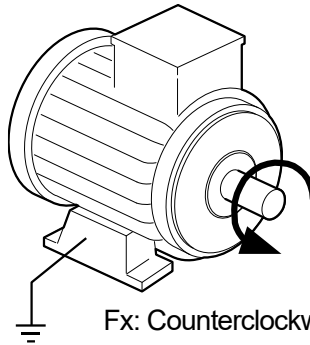

| Code | Name | Parameter Setting | Description |
|------|------------------------------|-------------------|------------------|
| dr20 | Rotation direction selection | F | Forward rotation |
| | | r | Reverse rotation |

5.4.2 Terminal Block as a Command Input Device (Fwd/Rev Run Commands)

Multi-function terminals can be selected as a command input device. This is configured by setting the drv code in the Operation group to 1. Select 2 terminals for the forward and reverse operations,

| Group | Code | Name | Parameter Setting | Setting Range | Initial Value | Unit |
|---------------------|------|---------------------------------------------------|-------------------|---------------|---------------|------|
| Operation | drv | Command source | 1 | 0 – 3 | 1 | - |
| In (Input Terminal) | 65 | Multi-function input terminal P1 function setting | 0 | 0 – 27 | 0 | - |
| | 66 | Multi-function input terminal P2 function setting | 1 | 0 – 27 | 1 | - |

When you use the multi-function input terminals P1 and P2 respectively for FX and RX operation. Set In65 and In66 in the Input Terminal (In) group respectively to 0 and 1 at the multi-function input terminals (standard I/O model: P1–P3, advanced I/O model: P1–P5). Set the relevant code (standard I/O model: In65–In67, advanced I/O model: In65–In69) to 0 (FX) and 1 (Rx).

FX is a forward operation command and RX is a reverse operation command.

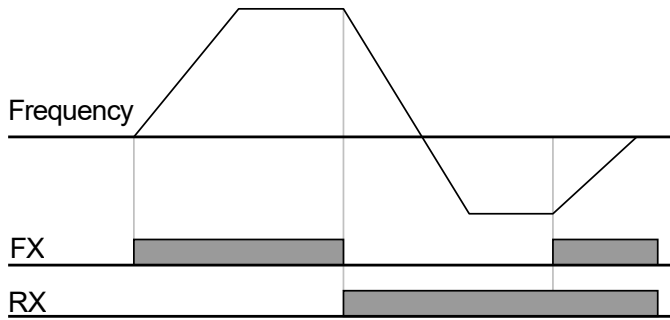

Note

This application enables both terminals to be turned on or off at the same time, constituting a stop command that will cause the inverter to stop operation.

5.4.3 Terminal Block as a Command Input Device (Run and Rotation Direction Commands)

| Group | Code | Name | Parameter Setting | Setting Range | Initial Value | Unit |
|---------------------|------|---------------------------------------------------|-------------------|---------------|---------------|------|
| Operation | drv | Command Source | 2 | 0–3 | 1 | - |
| In (Input Terminal) | 65 | Multi-function input terminal P1 function setting | 0 | 0–27 | 0 | - |
| | 66 | Multi-function input terminal P2 function setting | 1 | 0–27 | 1 | - |

Multi-function terminals can be selected as a command input device. This is configured by setting the drv code in the Operation group to 2. Select 2 terminals for operation commands and rotation directions selection.

When you use the multi-function input terminals P1 and P2 respectively for FX and RX operation. Set In65 and In66 in the Input Terminal (In) group respectively to 0 and 1 at the multi-function input terminals (standard I/O model: P1–P3, advanced I/O model: P1–P5). Set the relevant code (standard I/O model: In65–67, advanced I/O model: In65–69) to 0 (FX) and 1 (Rx).

FX (0): Assign a terminal for run command. When the RX terminal is set to OFF, the motor is run in the forward direction.

RX (1): Assign a terminal for changing the rotation direction. When the RX terminal is set to ON, the motor is run in the reverse direction.

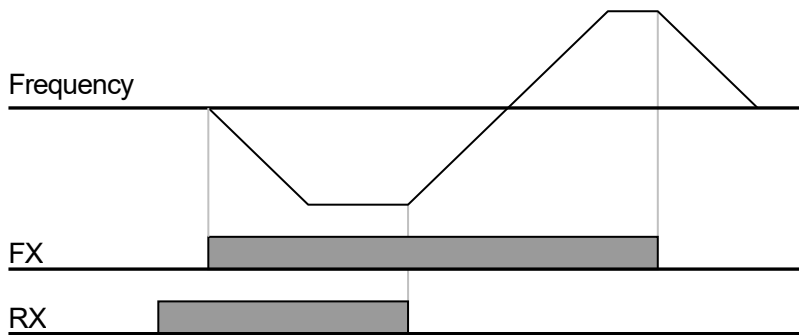

5.4.4 RS-485 Communication as a Command Input Device

RS-485 communication can be selected as a command input device by setting the drv code to 3 in the Operation group. This configuration uses upper level controllers such as PCs or PLCs to control the inverter. This feature is only available for models equipped with advanced I/O.

| Group | Code | Name | Parameter Setting | Setting Range | Initial Value | Unit |
|-----------------------|------|----------------------------------|-------------------|---------------|---------------|------|
| Operation | drv | Command source | 3 | 0 – 3 | 1 | - |
| CM (Communication) | 01 | Inverter station | - | 1 – 250 | 1 | - |
| | 02 | Communication protocol selection | - | 0 – 1 | 0 | - |
| | 03 | Communication speed | - | 0 – 4 | 3 | - |

Set communication protocol, inverter station, and communication speed and run the motor by RS-485 communication run command.

※ For more details about RS-485 communication features, refer to [8 RS-485 Communication Features](#) on page [171](#).

5.5 Forward or Reverse Run Prevention

The rotation direction of motors can be configured to prevent motors from only running in one direction. Set the Ad09 code in the Ad group to 0–2.

| Group | Code | Name | Initial Value | Description | Initial Value | Unit |
|---------------|------------------|------------------------------------|---------------|-----------------------------|---------------|------|
| dr (Drive) | 20 ¹⁾ | Run direction selection | F | Set forward run. | F | - |
| | | | r | Set reverse run. | | |
| Ad (Advanced) | 09 | Forward and reverse run prevention | 0 | Do not set run prevention. | 0 | - |
| | | | 1 | Set forward run prevention. | | |
| | | | 2 | Set reverse run prevention. | | |

1) The rotation direction command by the dr20 setting is applied only when drv(Command source) is set to 0. You can still display and set the dr20 setting when drv(Command source) is set to other than 0.

5.6 Power-on Run

| Group | Code | Name | Parameter Setting | Setting Range | Initial Value | Unit |
|---------------|------|----------------|-------------------|---------------|---------------|------|
| Operation | drv | Command source | 1, 2 | 0–3 | 1 | - |
| Ad (Advanced) | 10 | Power-on run | 1 | 0–1 | 0 | - |

A power-on command can be setup to start an inverter operation after powering up, based on terminal block operation commands (if they have been configured). To enable power-on run, set the Ad10 code to 1 in the Ad group.

This feature is not disabled when the [RUN] key on the keypad or RS-485 communication is selected as a command input device.

⚠ Caution

Use caution when operating the inverter with Power-on Run enabled as the motor will begin rotating when the inverter starts up.

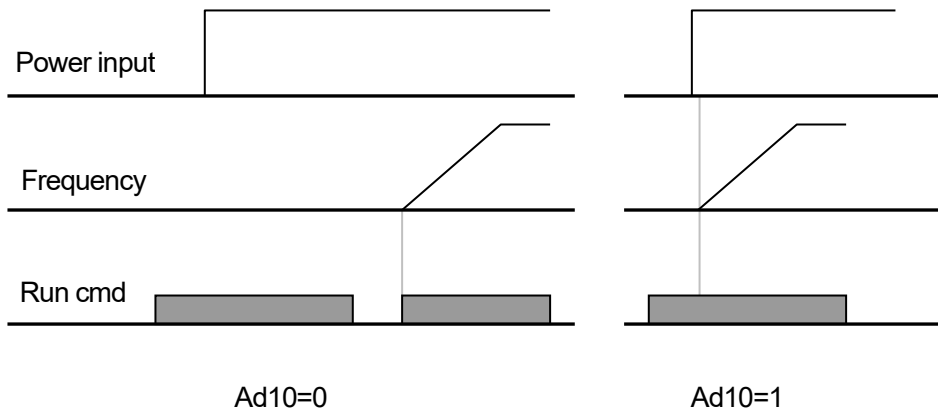

5.7 Reset and Restart

Reset and restart operations can be setup for inverter operation following a fault trip, based on the terminal block operation command (if it is configured). Set the Pr08 code to 1.

| Group | Code | Name | Parameter Setting | Setting Range | Initial Value | Unit |
|-----------------|------|---------------------|-------------------|---------------|---------------|------|
| Operation | drv | Command source | 1, 2 | 0-3 | 1 | - |
| Pr (Protection) | 08 | Reset restart setup | 1 | 0-1 | 0 | - |

This feature is not disabled when the [RUN] key on the keypad or RS-485 communication is selected as a command input device.

⚠ Caution

Use caution when operating the inverter with Reset and Restart enabled as the motor will begin rotating when reset is operated via terminal block or keypad after a trip.

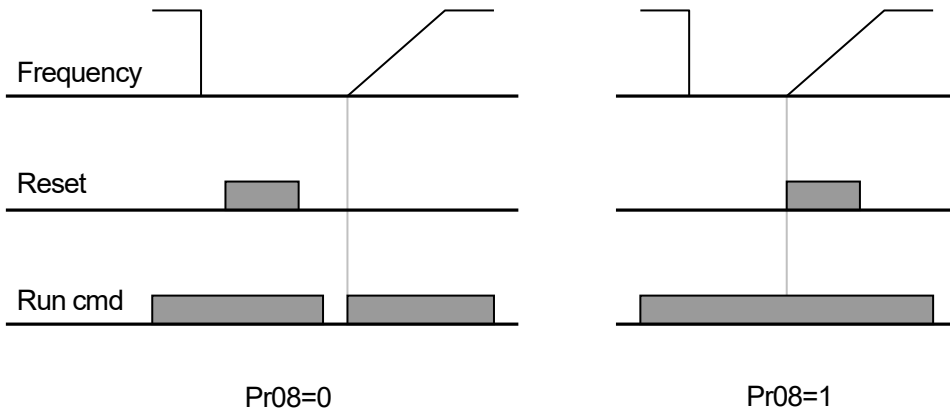

5.8 Setting Acceleration and Deceleration Times

5.8.1 Acc/Dec Time Based on Maximum Frequency

Acceleration and deceleration time values can be set at the ACC and dEC codes in the Operation group.

| Group | Code | Name | Parameter Setting | Setting Range | Initial Value | Unit |
|------------|------|-----------------------------|-------------------|---------------------------|---------------|------|
| Operation | ACC | Acceleration time | - | 0.0–6,000.0 ¹⁾ | 5.0 | sec |
| | dEC | Deceleration time | - | 0.0–6,000.0 ¹⁾ | 10.0 | sec |
| | FrM | Maximum frequency | - | 40.00–400.00 | 60.00 | Hz |
| bA (Basic) | 09 | Acc/Dec reference frequency | 0 | 0–1 | 0 | - |
| | 08 | Time scale | - | 0–2 | 1 | - |

1) Changes based on the bA08 code parameter setting.

Acc/Dec time values can be set based on maximum frequency, not on inverter operation, by setting the bA09 code to Acc/Dec and the reference frequency to 0.

Time scale for Acc/Dec time can be set at the bA08 code. If, for example, maximum frequency is 60.00 Hz, the Acc/Dec times are set to 5 seconds, and the frequency reference for operation is set at 30 Hz (half of 60 Hz), the time required to reach 30 Hz therefore is 2.5 seconds (half of 5 seconds).

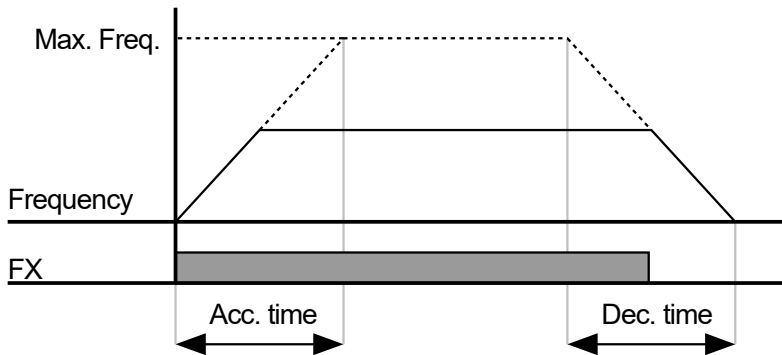

It is particularly useful that the time scale unit changes based on the max 5 digits of Acc/Dec time value when more accurate Acc/Dec times are required due to load characteristics.

If, for example, the Acc/Dec time scale changes to 0.01 second, the maximum Acc/Dec time will become 600.00 seconds. Refer to the following table.

| Code | Name | Parameter Setting | Time Scale Range | Initial Value | Description |
|------|------------|-------------------|-------------------|---------------|---------------------------------------|
| bA08 | Time scale | 0 | 0.01–600.00 [sec] | 1 | Sets 0.01 second as the minimum unit. |
| | | 1 | 0.1–6,000.0 [sec] | | Sets 0.1 second as the minimum unit. |
| | | 2 | 1–60,000 [sec] | | Sets 1 second as the minimum unit. |

5.8.2 Acc/Dec Time Based on Operation Frequency

| Group | Code | Name | Parameter Setting | Setting Range | Initial Value | Unit |
|------------|------|-------------------|-------------------|---------------------------|---------------|------|
| Operation | ACC | Acceleration time | - | 0.0–6,000.0 ¹⁾ | 5.0 | sec |
| | dEC | Deceleration time | - | 0.0–6,000.0 ¹⁾ | 10.0 | sec |
| bA (Basic) | 09 | Acc/Dec reference | 1 | 0–1 | 0 | - |

1) Changes based on the bA08 code parameter setting.

Acc/Dec times can be set based on the time required to reach the next step frequency from the existing operation frequency. To set the Acc/Dec time values based on the existing operation frequency, set bA09 (acc/dec reference) in the bA group to 1 (delta frequency).

If, for example, Acc/Dec reference is set to 1 (delta frequency) and acceleration time is set to 5 seconds, the operation frequency changes as shown in the graph below while the target frequency is set to 10 Hz at start and then changed to 30 Hz during section A.

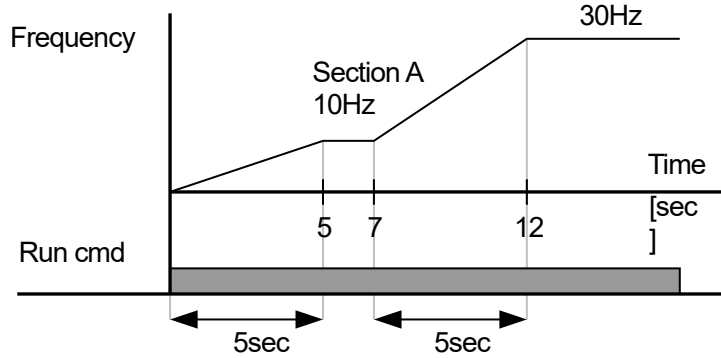

5.8.3 Multi-step Acc/Dec Time Configuration

| Group | Code | Name | Parameter Setting | Setting Range | Initial Value | Unit |
|---------------------|------------------|---------------------------------------------------|-------------------|-----------------------------|---------------|------|
| Operation | ACC | Acceleration time | - | 0.0 – 6,000.0 ¹⁾ | 5.0 | sec |
| | dEC | Deceleration time | - | 0.0 – 6,000.0 ¹⁾ | 10.0 | sec |
| In (Input Terminal) | 65 | Multi-function input terminal P1 function setting | 0 | 0–27 | 0 | - |
| | 66 | Multi-function input terminal P2 function setting | 1 | | 1 | - |
| | 67 | Multi-function input terminal P3 function setting | 8 | | 2 | - |
| | 68 ²⁾ | Multi-function input terminal P4 function setting | 9 | | 3 | - |
| | 69 ²⁾ | Multi-function input terminal P5 function setting | 10 | | 4 | - |

1) Changes based on the bA08 code parameter setting.

2) For models equipped with standard I/O, you can set the parameter via In65-67 (Multi-function input terminals P1-P3). You can use up to 3 multi-function input terminals for models equipped with standard I/O. If you must use more than 3 multi-function input terminals, use models equipped with advanced I/O.

| Group | Code | Name | Parameter Setting | Setting Range | Initial Value | Unit |
|------------|------|--------------------------------|-------------------|---------------|---------------|------|
| bA (Basic) | 70 | Multi-step acceleration time 1 | - | 0.0 – 6,000.0 | 2.0 | sec |
| | 71 | Multi-step deceleration time 1 | - | | 2.0 | |
| | 72 | Multi-step acceleration time 2 | - | | 3.0 | |
| | 73 | Multi-step deceleration time 2 | - | | 3.0 | |
| | 74 | Multi-step acceleration time 3 | - | | 4.0 | |
| | 75 | Multi-step deceleration time 3 | - | | 4.0 | |
| | 76 | Multi-step acceleration time 4 | - | | 5.0 | |
| | 77 | Multi-step deceleration time 4 | - | | 5.0 | |
| | 78 | Multi-step acceleration time 5 | - | | 4.0 | |
| | 79 | Multi-step deceleration time 5 | - | | 4.0 | |
| | 80 | Multi-step acceleration time 6 | - | | 3.0 | |
| | 81 | Multi-step deceleration time 6 | - | | 3.0 | |
| | 82 | Multi-step acceleration time 7 | - | | 2.0 | |
| | 83 | Multi-step deceleration time 7 | - | | 2.0 | |

Set a terminal to use as the Acc/Dec time command signal via the multi-function input terminals (standard I/O model: P1–P3, advanced I/O model: P1–P5).

Set the In67–69¹⁾ codes to 8–10 respectively to change the Acc/Dec time via the P3–P5¹⁾ terminals.

Multi-step acc/dec time 0 is set the ACC and dEC codes in the operation group.

Set multi-step acceleration/deceleration time1-7 at the bA70 – bA83 codes.

1) For models equipped with standard I/O, you can set the parameter via In65-67 (Multi-function input terminal P1-P3). You can use up to 3 multi-function input terminals for models equipped with standard I/O. If you must use 4 or 5 multi-function input terminals, use models equipped with advanced I/O.

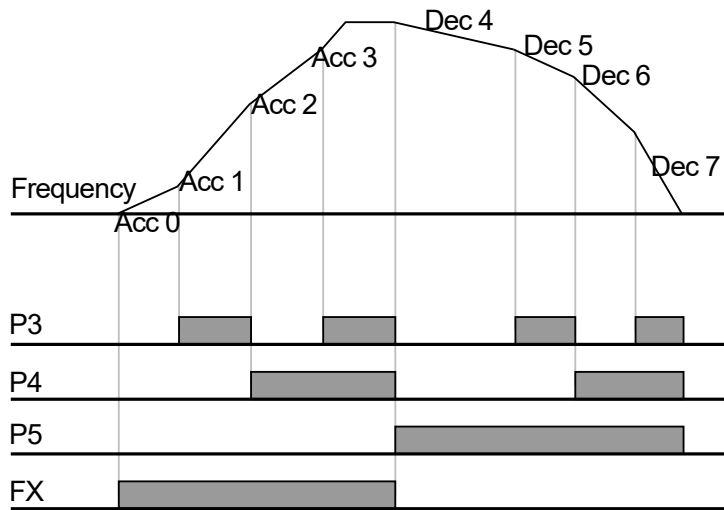

| Acc/Dec time | P5 | P4 | P3 |
|--------------|-------|-------|-------|
| 0 | - | - | - |
| 1 | - | - | ✓(+1) |
| 2 | - | ✓(+2) | - |
| 3 | - | ✓(+2) | ✓(+1) |
| 4 | ✓(+4) | - | - |
| 5 | ✓(+4) | - | ✓(+1) |
| 6 | ✓(+4) | ✓(+2) | - |
| 7 | ✓(+4) | ✓(+2) | ✓(+1) |

5.9 Acc/Dec Pattern Configuration

| Group | Code | Name | Setting Range | Initial Value | Unit | |
|------------------|------|------------------------|---------------|---------------------------|------|---|
| Ad (Advanced) | 01 | Acceleration pattern | 0 | Linear pattern operation | 0 | - |
| | | | 1 | S-curve pattern operation | | |
| | 02 | Deceleration pattern | 0 | Linear pattern operation | | |
| | | | 1 | S-curve pattern operation | | |
| | 03 | S-curve start gradient | 1–100 | 40 | % | |
| | 04 | S-curve end gradient | 1–100 | 40 | % | |

Acceleration patterns and deceleration patterns can be set respectively at the Ad01 and Ad02 codes in the Advanced (Ad) group.

Linear pattern: Features a linear increase or decrease to the output frequency at a fixed rate.

S-curve pattern: Features a smoother and more gradual increase or decrease of output frequency, ideal for lift-type loads, such as elevator doors, etc.

Note

If the S-curve reference acceleration time exceeds 60 seconds based on the maximum frequency, the S-curve is accelerated and decelerated linearly without performing the S-curve.

⚠ Caution

Actual Acc/Dec times become greater than user defined Acc/Dec times when S-curve Acc/Dec patterns are in use.

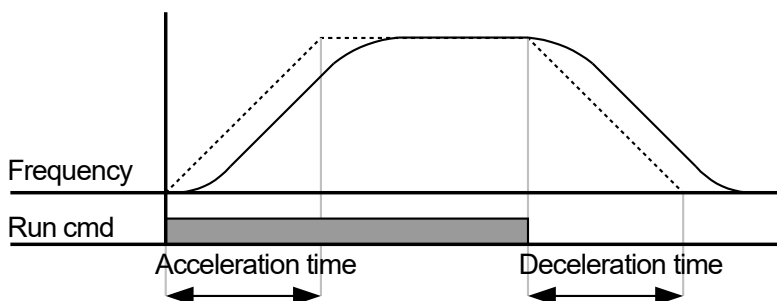

Ad03 defines the S-curve gradient level as a percentage, up to half of the total acceleration and deceleration (Acc Start and Dec Start) values. You can set the Ad03 parameter to a higher value to increase the gradient level for smoother acceleration and deceleration.

Ad04 defines the S-curve gradient level as a percentage, up to half of the remaining total acceleration and deceleration (Acc End and Dec End) values. You can set the Ad04 parameter to a higher value to increase the gradient level for smoother reach to constant speed and stop.

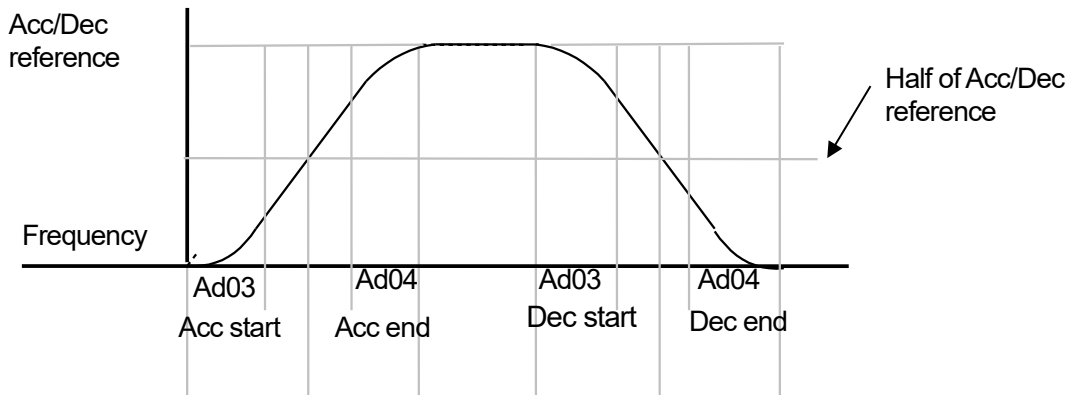

When Acc/Dec reference (bA09) is set to the maximum value while the goal frequency is lower than the maximum frequency, the S-curve is not created properly.

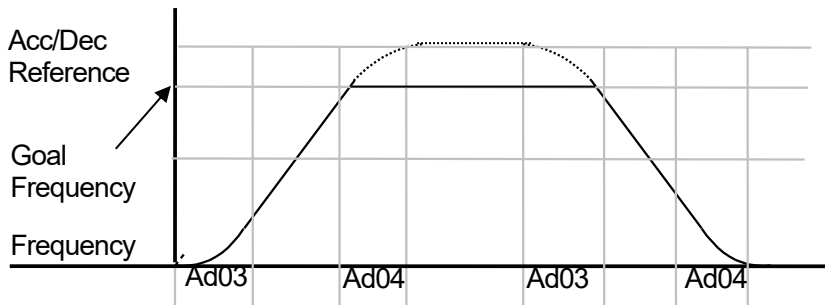

ⓘ Caution

Note that the upper part of the graph may be cut off if the frequency reference is lower than the maximum frequency.

Acceleration time when the S-curve pattern is set:

$$= ACC + ACC \times \frac{(Ad\ 3 / 100 \%)}{2} + ACC \times \frac{(Ad\ 4 / 100 \%)}{2}$$

Deceleration time when the S-curve pattern is set:

$$= dEC + dEC \times \frac{(Ad\ 3 / 100 \%)}{2} + dEC \times \frac{(Ad\ 4 / 100 \%)}{2}$$

The ACC and dEC in the formulas above are times set by the ACC and dEC codes in the Operation group.

5.10 Stopping the Acc/Dec Operation

Configure the multi-function input terminals to stop acceleration or deceleration and operate the inverter at a fixed output frequency.

| Group | Code | Name | Parameter Setting | Setting Range | Initial Value | Unit |
|---------------------|------------------|---------------------------------------------------|-------------------|---------------|---------------|------|
| In (Input Terminal) | 65 | Multi-function input terminal P1 function setting | - | 0-27 | 0 | - |
| | 66 | Multi-function input terminal P2 function setting | - | | 1 | |
| | 67 | Multi-function input terminal P3 function setting | - | | 2 | |
| | 68 ¹⁾ | Multi-function input terminal P4 function setting | - | | 3 | |
| | 69 ¹⁾ | Multi-function input terminal P5 function setting | 24 | | 4 | |

Select a terminal to use as an Acc/Dec stop command signal from multi-function input terminals (standard I/O model: P1–P3, advanced I/O model: P1–P5) and set a code from In65–69¹⁾ to 24.

Set the In69 code to 24 if the P5¹⁾ terminal is used as the Acc/Dec stop command.

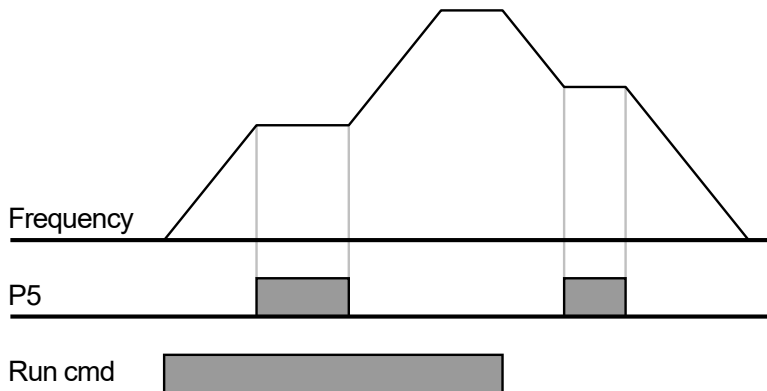

1) For models equipped with standard I/O, you can set the parameter via In65-67 (Multi-function input terminal P1-P3). You can use up to 3 multi-function input terminals for models equipped with standard I/O. If you must use more than 4 or 5 multi-function input terminals, use models equipped with advanced I/O.

5.11 V/F(Voltage/Frequency) Control

5.11.1 Linear V/F Pattern Operation

| Group | Code | Name | Parameter Setting | Setting Range | Initial Value | Unit |
|------------|------|-----------------|-------------------|---------------|---------------|------|
| Operation | MbF | Base frequency | - | 30.00–400.00 | 60.00 | Hz |
| dr (Drive) | 19 | Start frequency | - | 0.10–10.00 | 0.50 | Hz |
| | 09 | Control mode | - | 0–1 | 1 | - |
| bA (Basic) | 07 | V/F pattern | 0 | 0–2 | 0 | - |

A linear V/F pattern configures the inverter to increase or decrease the output voltage at a fixed rate for different operation frequencies based on V/F characteristics. Set the bA07 code in the Basic (bA) group to 0 (Linear).

Base frequency: The inverter's output frequency when running at its rated voltage. Refer to the motor's rating plate to set this parameter value.

Start frequency: A frequency at which the inverter starts voltage output

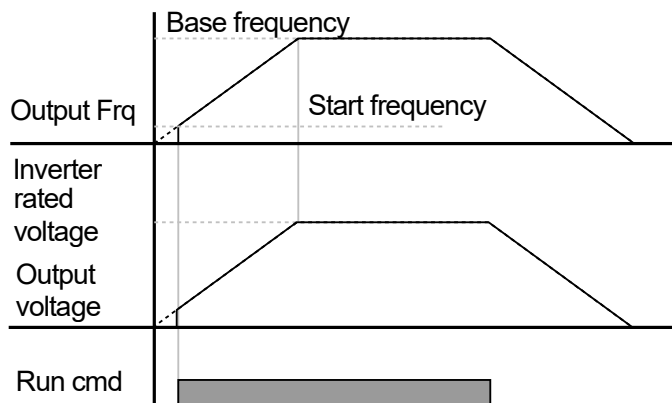

5.11.2 Square Reduction V/F pattern Operation

| Group | Code | Name | Parameter Setting | Setting Range | Initial Value | Unit |
|------------|------|-------------|-------------------|---------------|---------------|------|
| bA (Basic) | 07 | V/F pattern | 1 | 0–2 | 0 | - |

The inverter produces output voltage proportional to 2 square of the operation frequency by setting the bA07 code in the Basic group to 1 (Square reduction). This setup is ideal for loads such as fans or pumps.

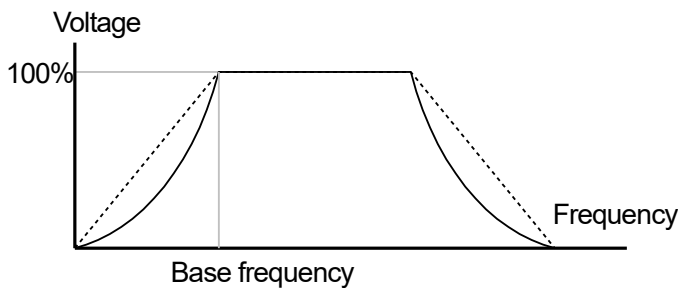

5.11.3 User V/F Pattern Operation

| Group | Code | Name | Parameter Setting | Setting Range | Initial Value | Unit |
|------------|------|----------------------|-------------------|--------------------|---------------|------|
| bA (Basic) | 07 | V/F pattern | 2 | 0–2 | 0 | - |
| | 41 | User V/F frequency 1 | - | 0.00– Max freq. | 15.00 | Hz |
| | - | - | - | - | - | - |
| | 48 | User V/F voltage 4 | - | 0–100 | 100 | % |

The M100 inverter allows the configuration of user-defined V/F patterns.

When the bA07 code is set to 2 (User V/F), user-defined V/F patterns can be configured to suit the load characteristics of special motors.

⚠ Caution

- When a normal induction motor is in use, care must be taken not to configure the output pattern away from a linear V/F pattern. Non-linear V/F patterns may cause insufficient motor torque or motor overheating due to over-excitation.
- When a user V/F pattern is in use, forward torque boost (Ftb) and reverse torque boost (rtb) do not operate.

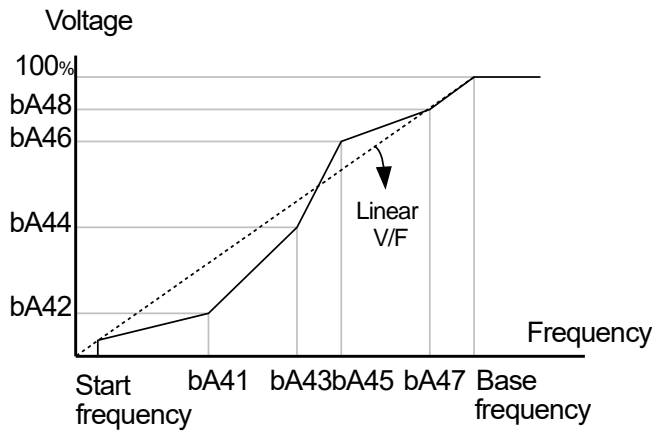

5.11.4 Output Voltage Setting

Output voltage settings are required when a motor’s rated voltage differs from the inverter’s input voltage. The set voltage becomes the output voltage of the inverter’s base frequency. If the frequency is higher than the base frequency, and the input voltage is lower than the parameter setting, the input voltage will become the inverter output voltage.

If this code is set to 0, the inverter corrects the output voltage based on an inactive input voltage.

This feature is used when a motor is operating with a voltage that is lower than the input voltage.

| Group | Code | Name | Parameter Setting | Setting Range | Initial Value | Unit |
|-----------|------|------------------------|-------------------|---------------|---------------|------|
| Operation | IOv | Output voltage setting | - | 0, 170~264 | 0 | V |

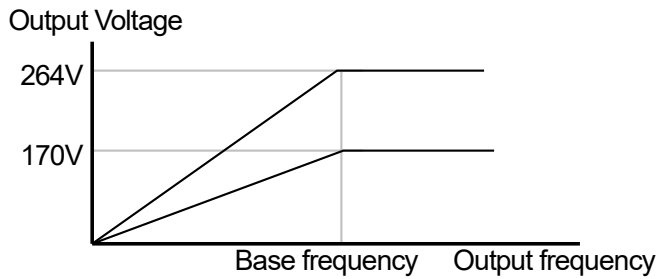

5.12 Torque Boost

5.12.1 Manual Torque Boost

| Group | Code | Name | Parameter Setting | Setting Range | Initial Value | Unit |
|------------|------|----------------------|-------------------|---------------|---------------|------|
| dr (Drive) | dr15 | Torque boost options | 0 | 0–1 | 0 | - |
| Operation | Ftb | Forward torque boost | - | 0.0–20.0 | 4.0 | % |
| | rtb | Reverse torque boost | | | | |

Manual torque boost enables users to adjust output voltage during low speed operation or motor start. Increase low speed torque or improve motor starting properties by manually increasing output voltage. Configure manual torque boost while running loads that require high starting torque, such as lift-type loads.

Torque boost can be set at the Ftb and rtb codes in the Operation group while the dr15 code is set to 0 (manual torque boost) in the Drive (dr) group.

Manual torque boost is disabled if the dr09(Control mode) code is set to 2(Simple sensorless control).

Manual Torque Boost Setting Details

| Code | Description |
|---------------------|-----------------------------------------|
| Ftb (Forward boost) | Set torque boost for forward operation. |
| rtb (Reverse boost) | Set torque boost for reverse operation. |

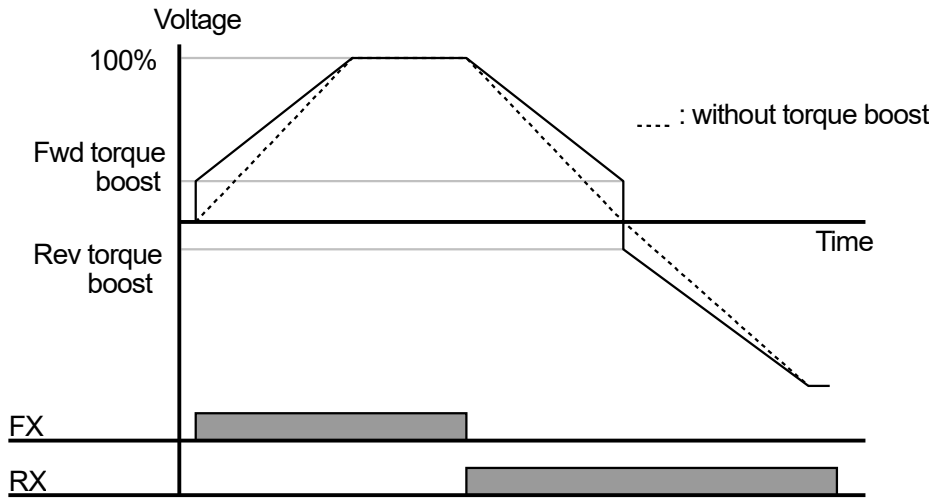

⚠ Caution

Excessive torque boost will result in over-excitation and motor overheating .

5.12.2 Auto Torque Boost

| Group | Code | Name | Parameter Setting | Setting Range | Initial Value | Unit |
|------------|------------------|--------------------------------------------|-------------------|---------------|---------------|------|
| dr (Drive) | 15 | Torque boost options | 1 | 0–1 | 0 | - |
| | 26 ¹⁾ | Auto torque boost filter gain | 2 | 1–1000 | 2 | - |
| | 27 ¹⁾ | Auto torque boost motoring gain | 120.0 | 0.0–300.0 | 120.0 | % |
| | 28 ¹⁾ | Auto torque boost regenerated voltage gain | 120.0 | 0.0–300.0 | 120.0 | % |
| Operation | Ftb | Forward torque boost | - | 0.0–20.0 | 4.0 | % |
| | rtb | Reverse torque boost | | | | |

1) Available with the dr15 (Torque boost options) set to 1.

You can use the parameter value displayed on the motor's rating plate without motor parameter tuning. Set the MbF (Base frequency), bA12 (Rated slip speed), MrC (Motor-rated current), bA14 (Motor no-load current, 40% of motor-rated current) codes to the value displayed on the motor's rating plate. If you do not use the value displayed on the motor's rating plate, each parameter value is set to the initial value and some features may be limited.

Auto torque boost basically operates with manual torque boost (Ftb, rtb) setting value, and the additional boost amount is determined according to the following situation.

The output voltage can be adjusted by adding voltage boost to the output voltage using torque current, when it is too low to start the V/F pattern operation. When the starting torque is too low or too high, the dr27 and dr28 codes (auto torque boost voltage gains) can be used for adjusting compensation based on the load.

Set the dr15 code to 1 (Auto torque boost) in the Drive (dr) group to output the voltage based on the torque boost. You can also change the dr26, dr27, and dr28 parameters.

Auto torque boost is disabled if the dr09 (Control mode) code is set to 1 (Slip compensation control).

5.13 Stop Mode Setting

5.13.1 Deceleration Stop

| Group | Code | Name | Parameter Setting | Setting Range | Initial Value | Unit |
|---------------|------|-----------|-------------------|---------------|---------------|------|
| Ad (Advanced) | 08 | Stop mode | 0 | 0-2 | 0 | - |

The operation frequency is decelerated to 0 Hz and stops running according to the set deceleration time by the stop command by setting the Ad08 code in the Advanced (Ad) group to 0 (Deceleration stop).

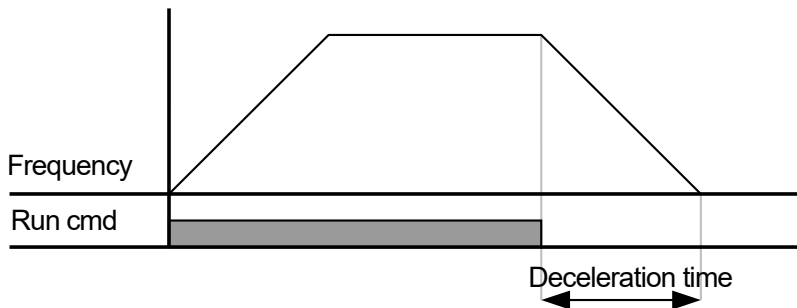

5.13.2 Stop After DC Braking

You can stop the motor by supplying DC power to the motor. Set the Ad08 code to 1 (DC braking).

| Group | Code | Name | Parameter Setting | Setting Range | Initial Value | Unit |
|---------------|------|-----------|-------------------|---------------|---------------|------|
| Ad (Advanced) | 08 | Stop mode | 1 | 0-2 | 0 | - |

5.13.3 Free Run Stop

To turn off the inverter output when the stop command is on, set the Ad08 code to 2 (Free run stop) in the Advanced (Ad) group.

| Group | Code | Name | Parameter Setting | Setting Range | Initial Value | Unit |
|---------------|------|-----------|-------------------|---------------|---------------|------|
| Ad (Advanced) | 08 | Stop mode | 2 | 0–2 | 0 | - |

When the operation command is off, the frequency and voltage outputs turn off.

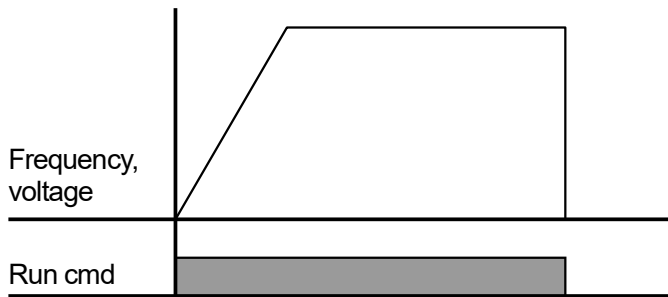

5.14 Frequency Limit

Configure the setting range of the command frequency.

5.14.1 Frequency Limit Using Maximum Frequency and Start Frequency

| Group | Code | Name | Parameter Setting | Setting Range | Initial Value | Unit |
|------------|------|-------------------|-------------------|---------------|---------------|------|
| Operation | FrM | Maximum frequency | - | 40.00–400.00 | 60.00 | Hz |
| dr (Drive) | 19 | Start frequency | - | 0.10–10.00 | 0.50 | Hz |

Maximum frequency: Set the upper limit value for parameters that are expressed as a frequency unit, except for MbF (Base frequency). You cannot set the frequency value higher than the maximum frequency within this function.

Start frequency: Set the lower limit value for parameters that are expressed as a frequency unit. If an input frequency is lower than the start frequency, the parameter value will be 0.00.

5.14.2 Frequency Limit Using Upper and Lower Limit Frequency Values

| Group | Code | Name | Parameter Setting | Setting Range | Initial Value | Unit |
|------------------|------------------|-------------------------------------|-------------------|----------------------------------------------|---------------|------|
| Ad (Advanced) | 24 | Frequency upper/lower limit options | 1 | 0–1 | 0 | - |
| | 25 ¹⁾ | Frequency lower limit | - | Start frequency– Frequency upper limit | 0.50 | Hz |
| | 26 ¹⁾ | Frequency upper limit | - | 0.00-Max frq. | 60.00 | Hz |

1) Available when the Ad24 code is set to 1.

Set the Ad24 code in the Ad group to 1. The inverter operates within the frequency range set at the Ad25 and Ad26 codes. When the frequency is set via analog input (or digital input) as shown in the graph below, the set frequency operates only within the upper limit and lower limit range.

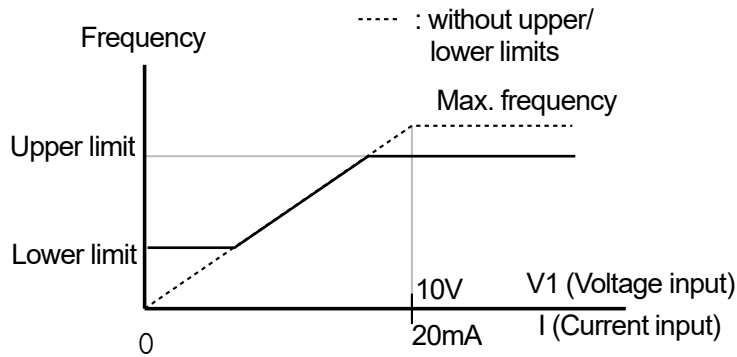

5.14.3 Frequency Jump

Use frequency jump to prevent the frequency setting within a specific section.

| Group | Code | Name | Parameter Setting | Setting Range | Initial Value | Unit |
|------------------|------------------|------------------------------|-------------------|--------------------------------------------------|---------------|------|
| Ad (Advanced) | 27 | Frequency jump | 1 | 0–1 | 0 | - |
| | 28 ¹⁾ | Frequency jump lower limit 1 | - | Start frequency– Frequency jump upper limit 1 | 10.00 | Hz |
| | 29 ¹⁾ | Frequency jump upper limit 1 | - | Frequency jump lower limit 1 –Max frq. | 15.00 | Hz |
| | 30 ¹⁾ | Frequency jump lower limit 2 | - | Start frequency– Frequency jump upper limit 2 | 20.00 | Hz |
| | 31 ¹⁾ | Frequency jump upper limit 2 | - | Frequency jump lower limit 2 –Max frq. | 25.00 | Hz |
| | 32 ¹⁾ | Frequency jump lower limit 3 | - | Start frequency– Frequency jump upper limit 3 | 30.00 | Hz |
| | 33 ¹⁾ | Frequency jump upper limit 3 | - | Frequency jump lower limit 3 –Max frq. | 35.00 | Hz |

1) Available when the Ad27 code is set to 1.

Set the Ad 27 code in the Ad group to 1. The command frequency cannot be set within the Ad 28–33 frequency range.

Upper limit and lower limit values for each section can be set within the range of the FrM

(Maximum frequency) and dr19 (Start frequency) codes.

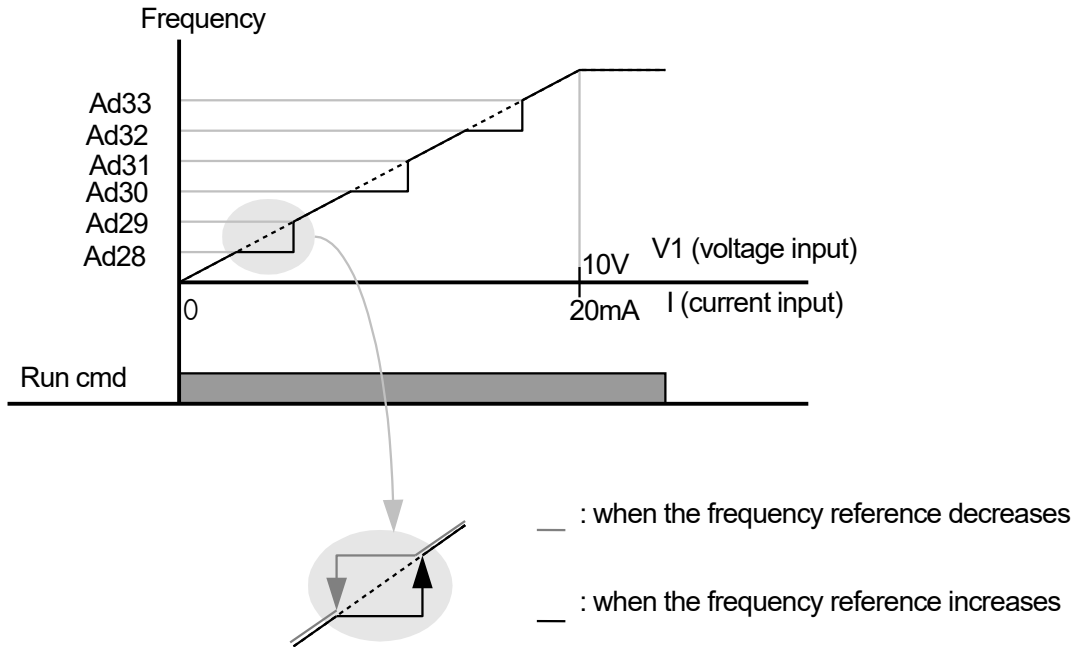

Use frequency jump to prevent motor operation at mechanical resonance frequencies. When jumping through a frequency bands while a motor accelerates and decelerates, operation frequencies cannot be set within the preset frequency jump band and the inverter operates at a constant speed.

When a frequency setting is increased, while the frequency parameter setting value (voltage, current, RS-485 communication, keypad setting, etc.) is within a jump frequency band, the frequency will be maintained at the lower limit value of the frequency band. Then, the frequency will increase when the frequency parameter setting exceeds the range of frequencies used by the frequency jump band.

On the contrary, when a frequency setting is decreased, while the frequency parameter setting value (voltage, current, RS-485 communication, keypad setting, etc.) is within a jump frequency band, the frequency will be maintained at the upper limit value of the frequency band. Then, the frequency will decrease when the frequency parameter setting exceeds the range of frequencies used by the frequency jump band.

5.15 Cooling Fan Control

This function turns the inverter’s heat-sink cooling fan on and off. It is used in situations where the load stops and starts frequently, or noise free environment is required. The correct use of cooling fan control can extend the cooling fan’s life. Ad.68 Fan Control is only applied to Advanced type.

| Group | Code | Name | Setting | Setting Range | Unit | |
|-------|------|---------------------|---------|---------------|------|---|
| Ad | 68 | Cooling fan control | 0 | During Run | 0–2 | - |

Cooling Fan Control Detail Settings

| Code and Features | Function | |
|-------------------|---------------|--------------------------------------------------------------------------------------------------------------------------------------------------------------------------------------------------------------------------------------------------------------------------------------------------------------------------------------------------|
| Ad.68 Fan Control | Configuration | |
| | 0 | During Run |
| | 1 | Always On |
| 2 | Temp Control | Function |
| | | Cooling fan runs when the power is supplied to the inverter and the operation command is on. The cooling fan stops when the power is supplied to the inverter and the operation command is off. When the inverter heat sink temperature is higher than its set value, the cooling fan operates automatically regardless of its operation status. |
| | | Cooling fan runs constantly if the power is supplied to the inverter. |
| | | With power connected and the run operation command on, if the setting is in Temp Control, the cooling fan will not operate unless the temperature in the heat sink reaches the set temperature. |

Note

Despite setting Ad.68 to 0 (During Run), if the heat sink temperature reaches a set level by current input harmonic wave or noise, the cooling fan may run as a protection function.

6 Learning Advanced Features

6.1 DC Braking

When the operation frequency reaches the set value during deceleration (DC braking frequency), the inverter stops the motor by supplying DC power to the motor.

6.1.1 Stop After DC Braking

With a stop command input, the inverter begins decelerating the motor. When the frequency reaches the DC braking frequency set at Ad17, the inverter supplies DC voltage to the motor and stops it.

| Group | Code | Name | Parameter Setting | Setting Range | Initial Value | Unit |
|------------------|------------------|----------------------------------|-------------------|---------------------------|---------------|------|
| Ad (Advanced) | 08 | Stop mode | 1 | 0–2 | 0 | - |
| | 14 ¹⁾ | Output block time before braking | - | 0.00–60.00 | 0.00 | sec |
| | 15 ¹⁾ | DC braking time | - | 0.0–60.0 | 1.0 | sec |
| | 16 ¹⁾ | DC braking amount | - | 0–200 | 50 | % |
| | 17 ¹⁾ | DC braking frequency | - | Start frequency –60.00 | 5.00 | Hz |

1) Available when the Ad08 code is set to 1.

Set the Ad08 code to 1 (DC braking stop) in the Advanced group.

Ad14: Set the time to block the inverter output before DC braking.

Ad15: Set the time duration for the DC voltage supply to the motor.

Ad16: Set the amount of DC braking to apply. The parameter setting is based on the rated current of the motor (MrC).

Ad17: Set the frequency to start DC braking.

ⓘ Caution

Note that the motor can overheat or be damaged if excessive amount of DC braking is applied to the motor, or DC braking time is set too long.

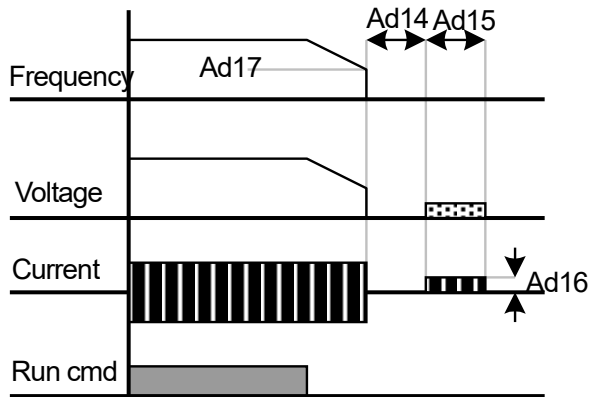

This feature is disabled if the Ad16 or Ad15 code is set to 0.

Output block time before braking (Ad14): If the inertia of the load is great, or if DC braking frequency is set too high, a fault trip may occur due to overcurrent conditions when the inverter supplies DC voltage to the motor. Prevent overcurrent fault trips by adjusting the output block time before DC braking (Ad14).

When the inertia of the load is great and DC braking frequency is set too high, modify the inertia rate at the bA16 code. The DC braking controller's controller gain will be changed based on the set value of the bA16 code.

| Code | Name | Parameter Setting | Description |
|------|--------------|-------------------|----------------------------------|
| bA16 | Inertia rate | 0 | Less than 10 times motor inertia |
| | | 1 | 10 times motor inertia |
| | | 2 | More than 10 times motor inertia |

6.1.2 Start After DC Braking

With the DC voltage is input, the inverter will begin accelerating the motor.

| Group | Code | Name | Parameter Setting | Setting Range | Initial Value | Unit |
|------------------|------|----------------------------|-------------------|---------------|---------------|------|
| Ad (Advanced) | 13 | DC braking amount at start | - | 0–200 | 50 | % |
| | 12 | DC braking time at start | - | 0.0–60.0 | 0.0 | sec |

Ad13: The parameter setting is based on the rated current of the motor (MrC).

Ad12: The motor accelerates after the DC voltage is supplied during the set time.

⚠ Caution

Note that the motor can overheat or be damaged if excessive amount of DC braking is applied to the motor, or DC braking time is set too long.

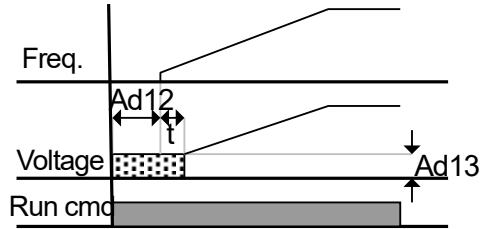

This feature is disabled if the Ad13 or Ad12 code is set to 0.

t : The acceleration frequency starts running after the duration set at the Ad12 code.

6.1.3 DC Braking During Stop

| Group | Code | Name | Parameter Setting | Setting Range | Initial Value | Unit |
|---------------------|------|---------------------------------------------------|-------------------|---------------|---------------|------|
| Ad (Advanced) | 13 | DC braking amount at start | - | 0–200 | 50 | % |
| In (Input Terminal) | 67 | Multi-function input terminal P3 function setting | 11 | 0–27 | 2 | - |

Ad13: The parameter setting is based on the rated current of the motor (MrC).

Select a terminal to use as the DC braking during a stop from the multi-function input terminal (standard I/O model: P1–P3, advanced I/O model: P1–P5).

If you select the P3 terminal to use as a frequency for the DC braking during a stop, the In67 code in the Input Terminal group must be set to 11 (DC braking during stop) as shown in the table above.

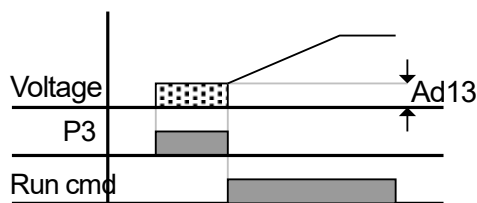

6.2 Jog operation

6.2.1 Jog Operation 1-Forward Jog by Multi-function Terminal

| Group | Code | Name | Parameter Setting | Setting Range | Initial Value | Unit |
|---------------------|------------------|---------------------------------------------------|-------------------|-------------------|---------------|------|
| dr (Drive) | 11 | Jog frequency | - | 0.00– Max frq. | 10.00 | Hz |
| In (Input Terminal) | 69 ¹⁾ | Multi-function input terminal P5 function setting | 4 | 0–27 | 4 | - |

1) For models equipped with standard I/O, you can set the parameter by In65-67 (Multi-function input terminal P1-P3).

You can set the jog frequency for operation by the dr11 code in the Drive (dr) group.

Select a terminal to use as a jog operation from the multi-function input terminals (standard I/O model: P1–P3, advanced I/O model: P1–P5).

If you select the P5 terminal to use as a jog operation terminal, the In69 code in the Input Terminal group must be set to 4 (Jog operation) as shown in the table above.

You can set the jog frequency range within the range of the maximum frequency (FrM) and the start frequency (dr19).

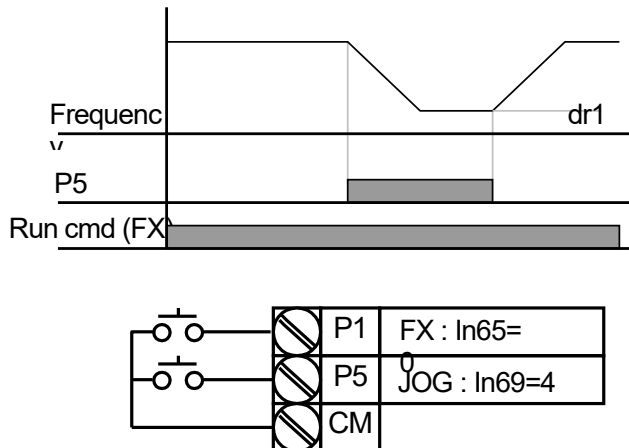

The jog operation is the second highest priority operation, after the dwell operation. If a jog operation is requested while operating the multi-step, up-down, or 3-wire operation modes, the jog operation overrides all other operation modes. The diagram above shows the example when the multi-function input is set to the NPN mode.

6.2.2 Jog Operation 2-Fwd/Rev Jog by Multi-function Terminal

| Group | Code | Name | Parameter Setting | Setting Range | Initial Value | Unit |
|---------------------|------------------|---------------------------------------------------|-------------------|-------------------|---------------|------|
| dr (Drive) | 11 | Jog frequency | - | 0.00–Max freq. | 10.00 | Hz |
| In (Input Terminal) | 68 ¹⁾ | Multi-function input terminal P4 function setting | 26 | 0-27 | 3 | - |
| | 69 ¹⁾ | Multi-function input terminal P5 function setting | 27 | 0-27 | 4 | - |

1) For models equipped with standard I/O, you can set the parameter by In65-67 (Multi-function input terminal P1-P3).

You can set the jog frequency for operation by the dr11 code in the Drive (dr) group.

Select a terminal to use as a JOG-FX operation from the multi-function input terminals (standard I/O model: P1–P3, advanced I/O model: P1–P5). The In68 code in the Input Terminal (In) group must be set to 24 (JOG-FX operation) to use the P4 terminal as a JOG-FX operation terminal.

You can set the jog frequency range within the range of the maximum frequency (FrM) and the start frequency (dr19).

The following graph is an example waveform of when the goal frequency is set to 30 Hz while the jog frequency is set to 10 Hz.

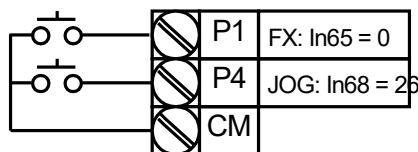
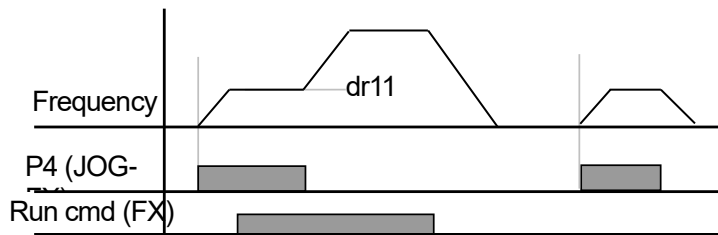

6.3 Up-down Operation

| Group | Code | Name | Parameter Setting | Setting Range | Initial Value | Unit |
|---------------------|------------------|---------------------------------------------------|-------------------|----------------|---------------|------|
| Operation | Frq | Frequency reference source | 10 | 0–11 | 0 | - |
| In (Input Terminal) | 65 | Multi-function input terminal P1 function setting | 0 | 0–27 | 0 | - |
| | 67 | Multi-function input terminal P3 function setting | 25 | | 2 | - |
| | 68 ¹⁾ | Multi-function input terminal P4 function setting | 15 | | 3 | - |
| | 69 ¹⁾ | Multi-function input terminal P5 function setting | 16 | | 4 | - |
| Ad (Advanced) | 65 | Up-down frequency save options | - | 0–1 | 0 | - |
| | 64 ²⁾ | Up-down frequency save | - | 0.00–Max freq. | 0.00 | Hz |

1) For models equipped with standard I/O, you can set the parameter by In65-67 (Multi-function input terminal P1-P3). You can use up to 3 multi-function input terminals for models equipped with standard I/O. If you must use more than 3 multi-function input terminals, use models equipped with advanced I/O.

2) Available when the Ad65 code is set to 1.

Up-down Frequency Save Details

You can set the up-down frequency save feature by setting the Frq (frequency reference source) code to 10 in the Operation group.

Select a terminal to use as the up-down operation frequency from the multi-function input terminals (standard I/O model: P1–P3, advanced I/O model: P1–P5).

The In68 and In69 codes must be set to 15 (Frequency increase) and 16 (Frequency reduction) respectively to use the P4 and P5 terminals as the up-down operation terminals.

The In67 code must be set to 25 (Up-down frequency save initialization) in the Input Terminal (In) group to use the P3 terminal as the terminal for the up-down frequency save initialization.

If the Ad65 code is set to 1 (Up-down frequency save options), the up-down save function allows the inverter to save the frequency to the Ad64 code before stopping or decelerating.

When the inverter is running the up-down operation, you can clear the saved up-down frequency setting by configuring the P3 terminal to 25 (Up-down frequency save initialization).

| Code | Name | Description | |
|------|--------------------------------|--------------------------|--------------------------------|
| Ad65 | Up-down frequency save options | 0 (Initial value) | Up-down frequency save off |
| | | 1 | Up-down frequency save setting |
| Ad64 | Up-down frequency save | Saves up-down frequency. | |

When the Up-down frequency save initialization signal is input to the P3 terminal while the Up terminal signal or the Down terminal signal is on, this signal becomes invalid.

Selecting Up-down Mode

| Group | Code | Name | Parameter Setting | Setting Range | Initial Value | Unit |
|---------------------|------------------|---------------------------------------------------|-------------------|-------------------|---------------|------|
| Operation | Frq | Frequency reference source | 10 | 0-10 | 0 | - |
| In (Input Terminal) | 65 | Multi-function input terminal P1 function setting | 0 | 0-27 | 0 | - |
| | 68 ¹⁾ | Multi-function input terminal P4 function setting | 15 | | 3 | - |
| | 69 ¹⁾ | Multi-function input terminal P5 function setting | 16 | | 4 | - |
| Ad (Advanced) | 66 | Up-down mode selection | - | 0-2 | 0 | - |
| | 67 | Up-down step frequency | - | 0.00-Max freq. | 0.00 | Hz |

1) For models equipped with standard I/O, you can set the parameter by In65-67 (Multi-function input terminal P1-P3).

You can set the up-down mode by setting the frequency reference source (Frq code) to 10 in the Operation group.

Select a terminal to use as an up-down operation frequency from the multi-function input terminals (standard I/O model: P1-P3, advanced I/O model: P1-P5).

The inverter is operated by the mode set by the step frequency at the Ad67 code.

Refer to the following table to learn how to select the up-down mode.

| Code | Name | Description | |
|------|--------------|----------------|--------------------------------------------------------------------------------------------|
| Ad66 | Up-down mode | 0 (Initial) | Increases or decreases the command frequency based on the maximum and minimum frequencies. |

| Code | Name | Description | |
|------|------------------------|------------------------------------------------------|-----------------------------------------------------------------------------------------------------------------|
| | selection | value) | |
| | | 1 | Increases or decreases the command frequency by the set up-down step frequency (Ad67) according the edge input. |
| | | 2 | Compound operation of 0 and 1 |
| Ad67 | Up-down step frequency | Frequency that will increase based on the edge input | |

When the Ad66 code is set to 0: If the Up terminal signal is on, the frequency reaches up to the maximum value for the set acceleration time. It reaches up to the upper limit when the upper limit has been set. If the Down terminal signal is on, the frequency decelerates to the value for the set deceleration time, regardless of the stop mode. It decelerates to the lower limit when the lower limit has been set.

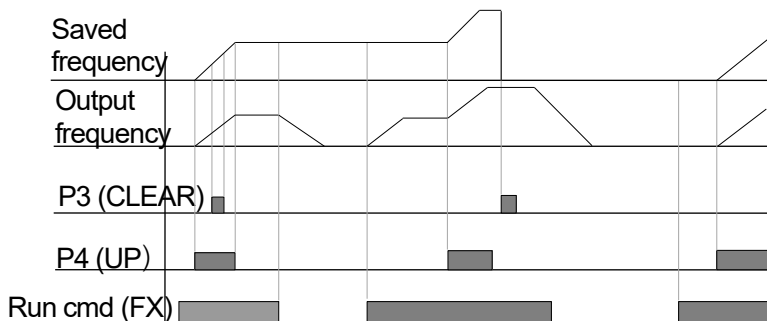
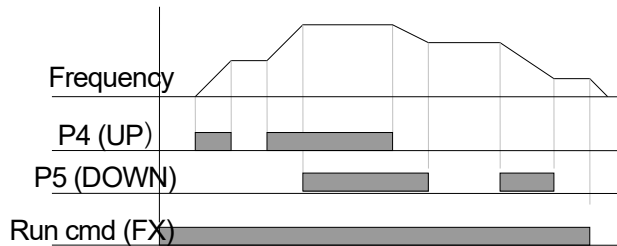
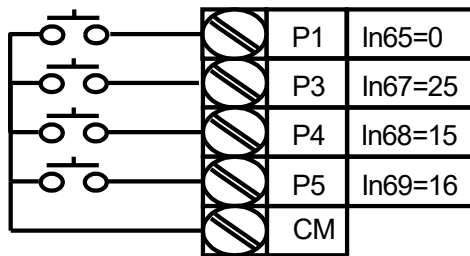

When the Ad66 code is set to 1: The motor accelerates by as much as the step frequency set by the Ad67 code at the multi-function input's positive edge that has been set as the Up

terminal signal. The motor decelerates by as much as the step frequency set at the Ad67 code at the multi-function input's positive edge that has been set as the Down signal. The frequency is saved at the falling edge when the Up/down signal is specified. In this case, when the stop command is supplied while the multi-function input set as the Up or Down signal has been set, the previous edge value is saved continuously and the current frequency is not saved, even when the multi-function input is not set during a stop. The acc/dec time is identical to the time when 0 is set.

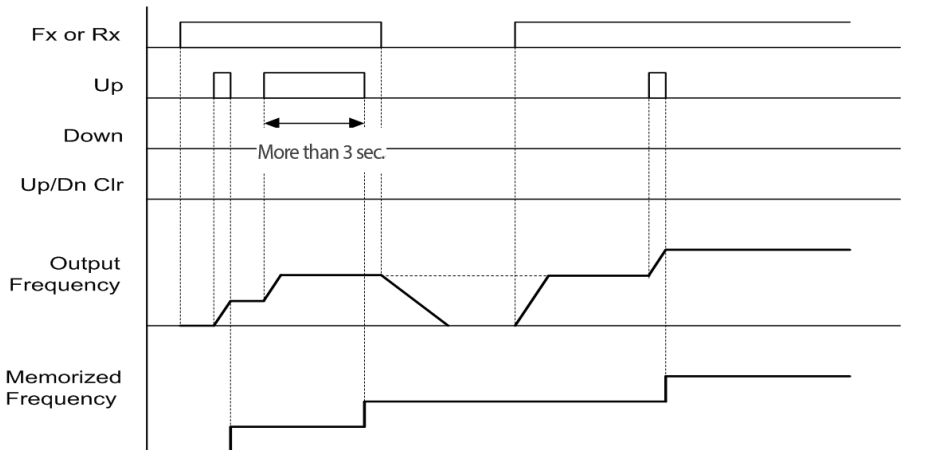

When the Ad66 code is set to 2: The motor accelerates by as much as the step frequency set by the Ad67 code at the multi-function input's positive edge that has been set as the Up terminal signal. The motor operation is identical to when 0 is set when the function is activated for more than 3 seconds. The motor decelerates by as much as the step frequency set at the Ad67 code at the multi-function input's positive edge that has been set as the Down signal. The motor operation is identical to when 0 is set when the function is activated for more than 3 seconds, and the acc/dec time is identical to the time when 0 is set.

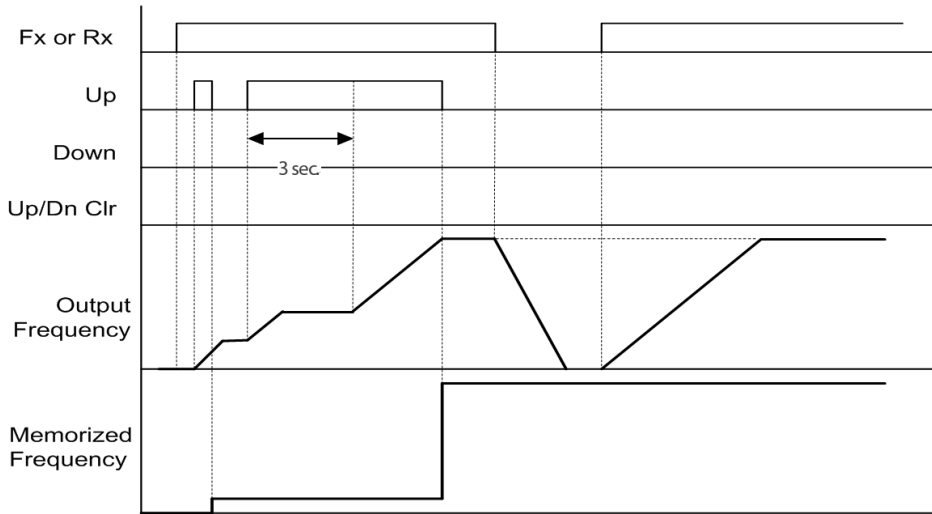

ⓘ Caution

The signal is void when the input is supplied again before it increases 1 step frequency by the Up or Down signal. The frequency at deactivation is saved.

6.4 3-Wire Operation

| Group | Code | Name | Parameter Setting | Setting Range | Initial Value | Unit |
|---------------------|------------------|---------------------------------------------------|-------------------|---------------|---------------|------|
| In (Input Terminal) | 65 | Multi-function input terminal P1 function setting | - | 0-27 | 0 | - |
| | ~ | ~ | ~ | | ~ | |
| | 69 ¹⁾ | Multi-function input terminal P5 function setting | 17 | | 4 | |

1) For models equipped with standard I/O, you can set the parameter by In65-67 (Multi-function input terminal P1-P3).

Select a terminal to use as a 3-wire operation from the multi-function input terminals (standard I/O model: P1-P3, advanced I/O model: P1-P5). The In67 code must be set to 17 (3-wire command) in the Input Terminal group to set the P3 terminal as a 3-wire operation terminal.

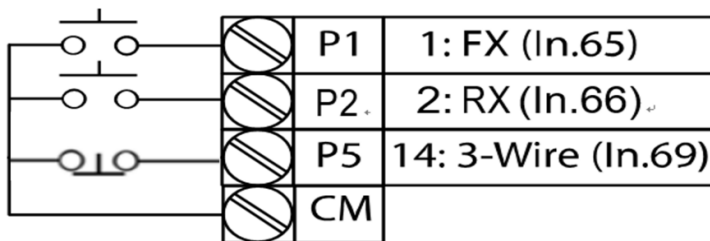
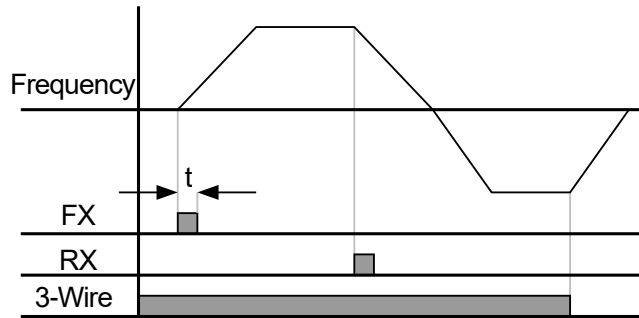

The 3-wire operation latches the signal input (the signal stays on after the button is released) as shown in the diagram above, and is used when operating the inverter with a push button switch.

Pulse width (t) of command in the diagram above must be at least 50 msec.

6.5 Dwell Operation

When an operation command runs, acceleration starts after running by set dwell frequency during dwell operation time. The inverter can be used for dwell frequency operations before opening the mechanical brake of lift-type loads and for opening the brake.

| Group | Code | Name | Parameter Setting | Setting Range | Initial Value | Unit |
|------------------|------|-----------------|-------------------|------------------------------------------|---------------|------|
| Ad (Advanced) | 20 | Dwell frequency | - | Start frequency– Maximum frequency | 5.00 | Hz |
| | 21 | Operation time | - | 0.0–10.0 | 0.0 | sec |

Dwell frequency: A rated slip frequency that supplies the rated torque to the motor before opening the mechanical brake of lift-type loads. The rated slip frequency is different from the rated frequency converted from the rated RPM on the motor rating plate.

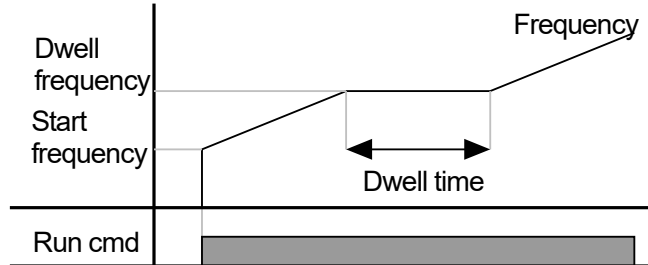

Note

Dwell operation does not work when:

- Dwell operation time is set to 0 sec or dwell frequency is set to 0 Hz.
- Re-acceleration is attempted from stop, as only the first acceleration dwell operation command is valid.

[Dwell operation]

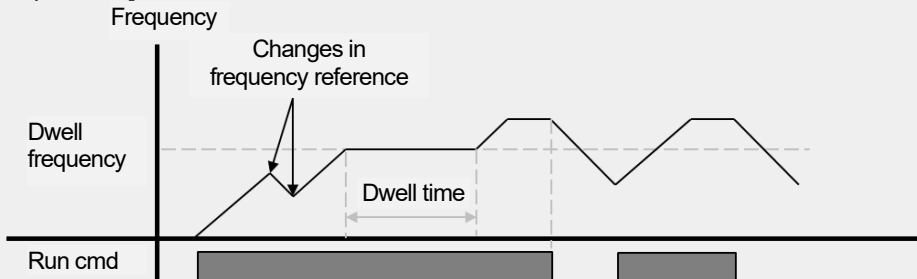

⚠ Caution

When a dwell operation is carried out for a lift - type load before its mechanical brake is released, motors can be damaged or their lifecycle reduced due to overflow current in the motor.

6.6 Slip Compensation Operation

| Group | Code | Name | Parameter Setting | Setting Range | Initial Value | Unit |
|------------|------|----------------------------|-------------------|---------------|---------------|------|
| Operation | MrC | Motor rated current | - | 0.1–150.0 | - | A |
| | MkW | Motor capacity option | - | 0.1–2.2 | - | kW |
| bA (Basic) | 11 | Number of motor poles | - | 2–12 | 4 | - |
| | 12 | Motor rated slip frequency | - | 0.00–10.00 | - | Hz |
| | 14 | Motor no-load current | - | 0.1–100.0 | - | A |
| | 15 | Motor efficiency | - | 50–100 | - | % |
| | 16 | Load inertia rate | - | 0–2 | 0 | - |
| dr (Drive) | 09 | Control method option | 1 | 0–2 | 1 | - |

(Initial values of the MrC and bA12–15 codes are determined by the MkW parameter.)

Set the dr09 code in the Drive group to 1 (Slip compensation control).

This feature ensures that the motor rotates at a constant speed, by compensating for the motor slip as a load increases.

MkW: Set the capacity of the motor connected to the inverter output terminal.

| Code | Name | Parameter Setting | Description |
|------|-----------------------|-------------------|-------------|
| MkW | Motor capacity option | 0.1 | 0.1kW |
| | | ~ | ~ |
| | | 2.2 | 2.2kW |

bA11: Enter the number of poles from the motor rating plate.

bA12: Enter the motor-rated slip frequency referring to the motor rating plate and the following formula:

$$f_s = f_r - \left(\frac{rpm \times P}{120} \right)$$

f_s = Rated slip frequency

f_r = Rated frequency

rpm = Number of the rated motor rotations

P = Number of motor poles

Example) When the rated frequency is 60 Hz, the number of the rated motor rotations is 1740 rpm, and the number of motor poles is 4:

$$f_s = 60 - \left(\frac{1740 \times 4}{120} \right) = 2Hz$$

MrC: Enter the rated current from the motor rating plate.

bA14: Enter the measured current when the load on the motor axis is removed and when the motor is operated at the rated frequency. If no-load current is difficult to measure, enter a current equivalent to 40 % of the rated motor current.

bA15: Enter the efficiency from the motor rating place.

bA16: Select load inertia based on motor inertia.

| Code | Name | Parameter Setting | Description |
|------|--------------|-------------------|----------------------------------|
| bA16 | Inertia rate | 0 | Less than 10 times motor inertia |
| | | 1 | 10 times motor inertia |
| | | 2 | More than 10 times motor inertia |

For the induction motor, the difference between the number of motor rotations and frequency (synchronous speed) increases according to the load rate as shown in the graph below. Therefore, the slip compensation control is used when the speed difference must be decreased.

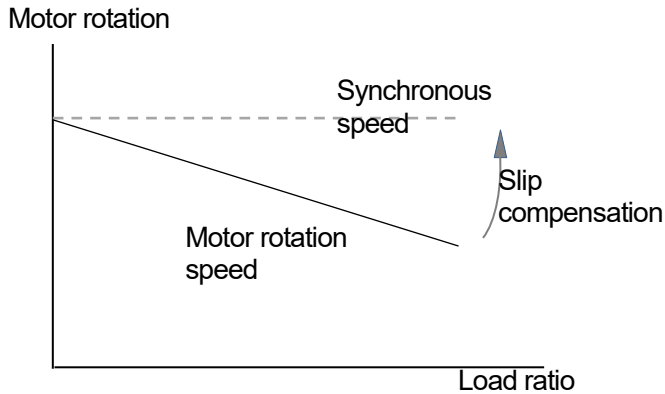

6.7 Simple Sensorless Control

| Group | Code | Name | Parameter Setting | Setting Range | Initial Value | Unit |
|------------|------|--------------|-------------------|---------------|---------------|------|
| dr (Drive) | 09 | Control mode | 2 | 0-2 | 1 | - |

Set the dr09 Code in the dr group to 2.

Simple sensorless control automatically increases the starting torque when high starting torque is required to enable starting. It also compensates for the slip of the motor so that it can rotate at a constant speed.

Manual torque boost is disabled if the Dr09(Control mode) code is set to 2(Simple sensorless control).

6.8 PID Control

| Group | Code | Name | Parameter Setting | Setting Range | Initial Value | Unit |
|---------------------|--------------------|-----------------------|-------------------|----------------------------|---------------|-----------|
| AP (Application) | 01 | PID control selection | 1 | 0-1 | 0 | - |
| | 18 ¹⁾²⁾ | PID feedback | - | 0.00-400.00 / 0.0-100.0 | 0.00 / 0.0 | Hz / % |

| Group | Code | Name | Parameter Setting | Setting Range | Initial Value | Unit |
|---------------------|--------------------|------------------------------------------------|-------------------|-------------------------------------------------|---------------|-----------|
| | 19 ¹⁾²⁾ | PID reference | - | 0.00– Max freq. / 0.0–100.0 | 0.00 / 0.0 | Hz / % |
| | 20 ¹⁾ | PID reference source | - | 0–5 | 0 | - |
| | 21 ¹⁾ | PID feedback source | - | 0–3 | 2 | - |
| | 22 ¹⁾ | PID controller P gain | - | 0.0–999.9 | 300.0 | % |
| | 23 ¹⁾ | PID controller integral time (I gain) | - | 0.10–32.00 | 1.00 | sec |
| | 24 ¹⁾ | PID controller differentiation time (D gain) | - | 0.00–30.00 | 0.00 | sec |
| | 28 ¹⁾ | PID mode | - | 0–1 | 0 | - |
| | 29 ¹⁾ | PID output frequency upper limit | - | PID output freq. Lower limit– Max freq. | 60.00 | Hz |
| | 30 ¹⁾ | PID output frequency lower limit | - | Start freq.– PID output freq. upper limit | 0.50 | Hz |
| | 02 ¹⁾ | PID scale selection | - | 0–1 | 0 | - |
| | 37 ¹⁾ | Sleep mode delay time | - | 0.0–2000.0 | 60.0 | sec |
| | 38 ¹⁾ | Sleep mode frequency | - | 0.00–Max freq. | 0.00 | Hz |
| | 39 ¹⁾ | Wake-up Level | - | 0.0–100.0 | 35.0 | % |
| In (Input Terminal) | 65 | Multi-function input terminal function setting | 21 | 0–27 | - | - |

1) Available when the AP01 code is set to 1.

2) The parameter of the AP19 and AP20 codes are displayed in a different format depending on the AP02 parameter. (Frequency when AP02=0, percentage when AP02=1)

6.8.1 PID Basic Control

PID control provides constant automated control of flow, pressure, and temperature by adjusting the output frequency of the inverter.

Set the AP01 code to 1 (PID operation) in the Application (AP) group. Then, you can set the PID reference at AP19 and monitor the actual PID feedback volume.

There are 2 types of PID operation mode; normal PID mode and process PID mode. You can set the PID operation mode by AP28 (PID mode).

AP21: Set the feedback source of the PID controller.

| Code | Name | Parameter Setting | Description |
|------|---------------------|-------------------|------------------------------------------------------------------|
| AP21 | PID feedback source | 0 | I2 (I input) of analog input terminal (0-20 [mA]) ¹⁾ |
| | | 1 | I2 (V input) of analog input terminal (0-10 [V]) ¹⁾ |
| | | 2 | V1 terminal input of analog input terminal block (0-10 [V]) |
| | | 3 | RS-485 communication ¹⁾²⁾ |

1) Available only for models equipped with advanced I/O.

2) When you input the PID feedback via RS-485 communication, you can read and/or write in 0.1 % increments using 0x001E (common address), regardless of the AP02 (PID unit selection) value.

AP22: Sets the P gain as the output ratio to the error rate. If the P gain is set to 50%, 50% of the error is output. Higher input value leads to reaching the target control variable faster, but oscillation may occur at the controller when the value is too high.

AP23: Sets the time to output accumulated errors. When the error is 100%, the time taken for 100% output is set. When the integral time is set to 1 second, 100% output occurs after 1 second of the error remaining at 100%. Differences in a normal state can be reduced by the integral time. Adjusting the value leads to a faster response, but oscillation may occur at the controller.

AP24: Sets the output volume for the rate of change in errors. M100 detects error every 1 ms. When the differential time is set to 1 ms and the rate of change in errors per sec is 100%, output occurs at 1% per 10 ms.

AP28: Adds the set target to the PID controller and sets the volume of the target.

AP29, AP30: Limits the output of the controller.

AP20: Selects the PID reference source.

AP02: You can set the unit of the PID reference (AP19) and PID feedback (AP18) to Hz (frequency) or % (percentage). (AP02 = 0: Hz, AP02 = 1: %)

In65-In69: When one the multi-function input terminal P1-P5 is set to 21 (PID switch operation) and turn the terminal ON, the PID control is switched to normal PID control where the command frequency is operated as the PID reference but not as the PID controller output.)

rPM: Converts the feedback volume set at AP21 to motor frequency.

When running the PID switch operation, the output frequency is displayed, but the feedback volume is not displayed.

Normal PID operation (AP28=0)

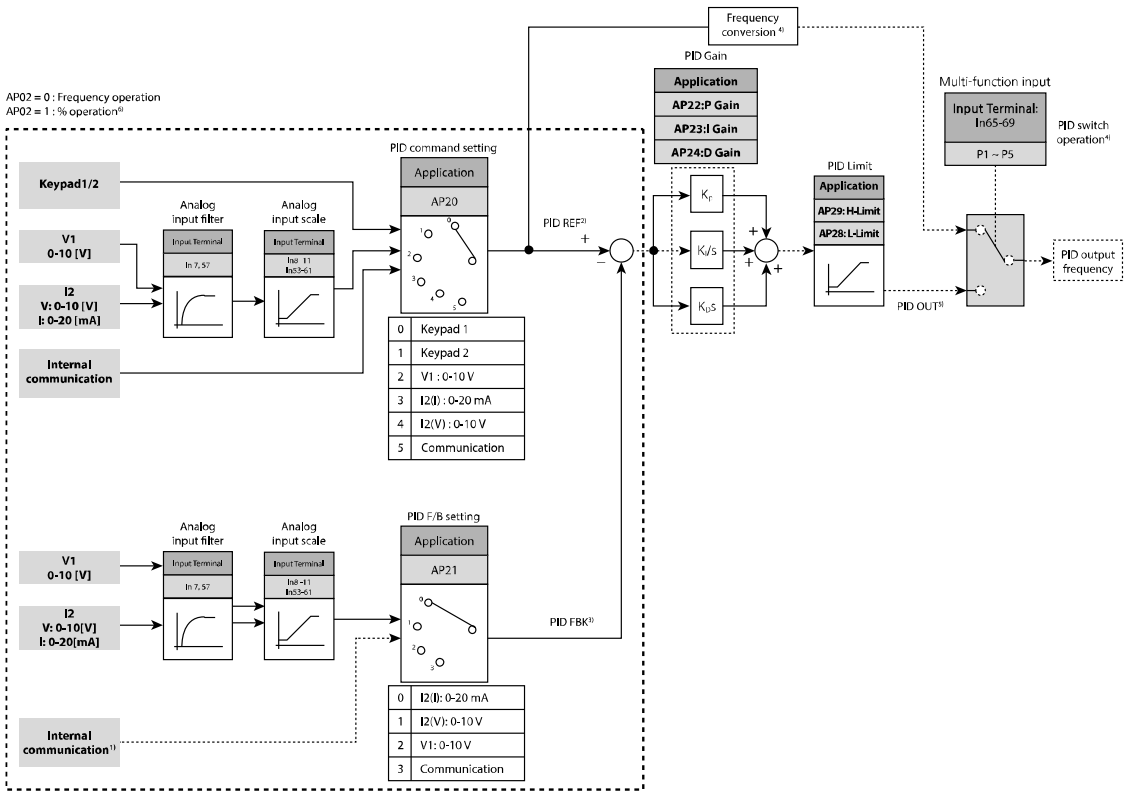

Normal PID control block diagram

- 1) RS-485 communication is added to the PID feedback group.
- 2) PID REF (PID reference) value can be checked and configured at AP19. When AP02 = 0, the unit is set to [Hz]. When AP02 = 1, the unit is set to [%].
- 3) PID FBK (PID feedback volume) value can be checked at AP18. The unit is identical to the unit of the AP19 parameter value.
- 4) When the PID switch operation (21, PID operation switched to normal operation) signal is input to the multi-function input (standard I/O model: P1–P3, advanced I/O model: P1–P5) while the AP02 is set to 1, percentage value is converted and output to the frequency value.
- 5) Polarity of PID OUT (Normal PID output) is unipolar, and it is limited by AP29 (H-Limit, Frequency jump upper limit 1) and AP28 (L-Limit, Frequency jump lower limit 1).
- 6) 100.0% is the FrM (maxFreq that is the maximum frequency) parameter setting.

Process PID operation (AP28=1)

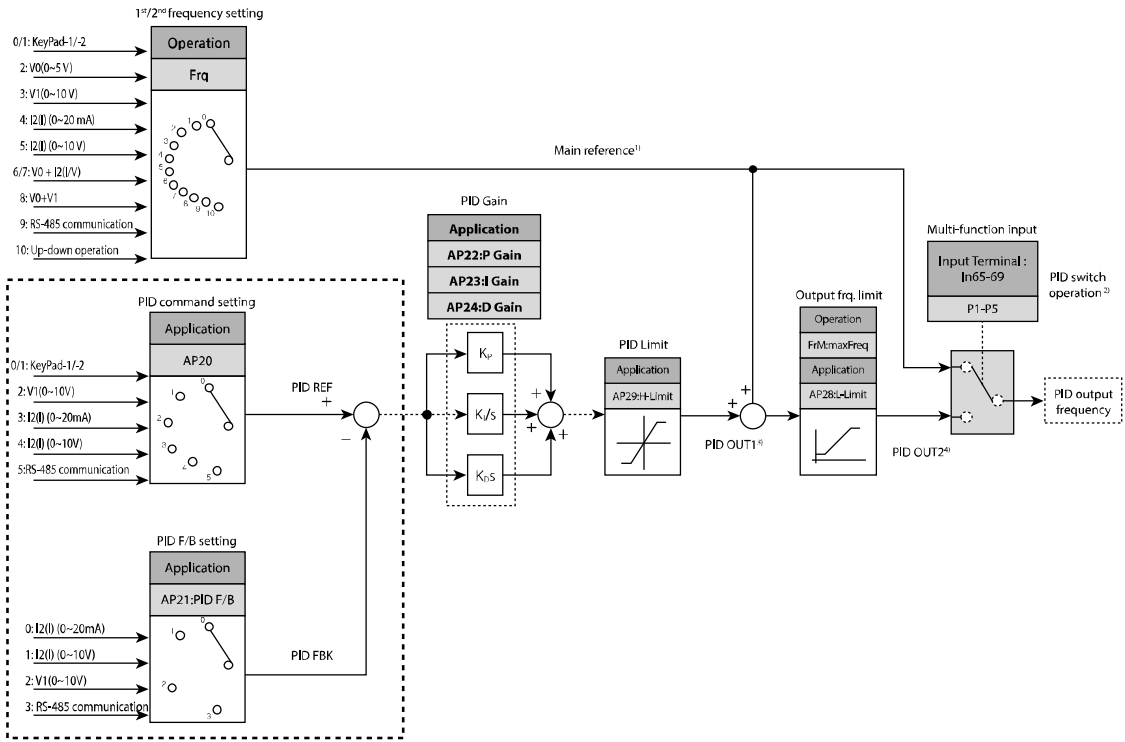

AP02 = 0 : frequency operation
 AP02 = 1 : % operation

Process PID control block diagram

- 1) Main reference is a frequency (Frq=10, Up/Down operation excluded) set at the Frq/bA05 codes in the Operation group, and the actual output frequency is the main reference and PID OU2 (PID block output).
- 2) When the PID switching operation is selected, the main reference becomes the actual output frequency.
- 3) PID OU1, the output in the PID block diagram, is bipolar and the parameter is limited by the AP29 (PID upper limit) code.
- 4) PID OU2 is the actual frequency and is limited by the FrM (maxFreq, the maximum frequency) and AP28 (L- Limit, frequency jump lower limit 1) codes.

Other operations are identical to those using normal PID operation.

PID Sleep & Wake-up

The inverter automatically enters sleep mode and stops operating when the PID controller's output frequency is maintained at the sleep frequency (AP38) for sleep delay time (AP37). Monitoring still operates in the sleep mode, and the inverter wakes up and runs again when deviation between the PID reference and the feedback volume becomes higher than the wake-up level (AP39).

Sleep mode is disabled when a stop command is input.

This feature can be used, for example, at night when the flow rate to the pump load is low.

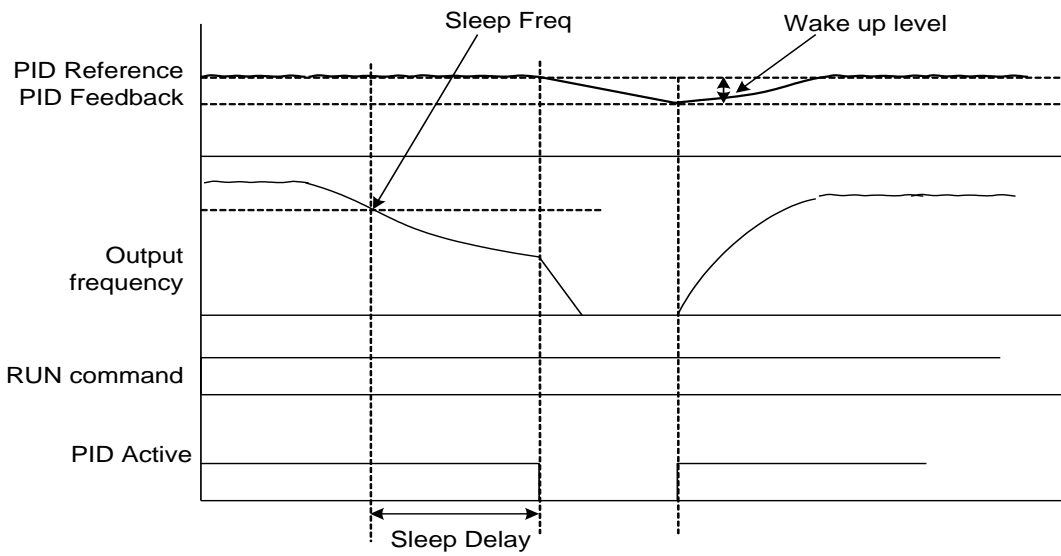

6.9 Energy Saving Operation

| Group | Code | Name | Parameter Setting | Setting Range | Initial Value | Unit |
|---------------|------|-------------------------|-------------------|---------------|---------------|------|
| Ad (Advanced) | 51 | Energy saving operation | - | 0-30 | 0 | % |

You can set the reduced amount of the output voltage at the Ad51 code based on the maximum output voltage (IOv).

This operation is used to save energy by reducing the voltage supplied to motors during low-load and no-load conditions when a fan or pump is operating.

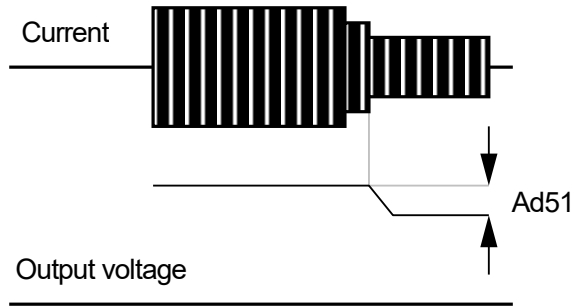

6.10 Speed Search Operation

| Group | Code | Name | Parameter Setting | Setting Range | Initial Value | Unit |
|----------------------|-----------|----------------------------------------------------------------------------------------------------|-------------------|---------------|---------------|------|
| Cn (Control) | 71 | Speed search selection | - | 0000–1111 | 0000 | Bits |
| | 72 | Speed search current level | - | 80–200 | 100 | % |
| | 73 | Speed search P gain | - | 0–9999 | 500 | - |
| | 74 | Speed search I gain | - | 0–9999 | 1000 | - |
| OU (Output Terminal) | 31/ 32 | Multi-function relay function selection / Multi-function output 2 nd function selection | 15 | 0–19 | 17 | - |

This operation is used to prevent fault trips that can occur while the inverter output voltage is disconnected and the motor is idling.

Because this feature estimates the motor rotation speed based on the inverter output current, it does not give the exact speed.

You can select a speed search operation from the following four types.

| Code | Name | BIT | Function |
|------|------------------------|------|------------------------------------------------|
| Cn71 | Speed search selection | ---1 | Speed search for general acceleration |
| | | --1- | Initialization after a fault trip (Pr08=1) |
| | | -1-- | Restart after instantaneous power interruption |
| | | 1--- | Starting with power-on (Ad10) |

Cn72: The amount of current flow is controlled during speed search operation based on the motor's rated current (MrC).

Cn73, Cn74: The P/I gain of the speed search controller can be adjusted. The P/I gain are adjusted according to the characteristics of a load.

OU31, OU32: Outputs the speed search operation state to the external sequence using a multi-function relay (3ABC).

Example) After an instantaneous power interruption

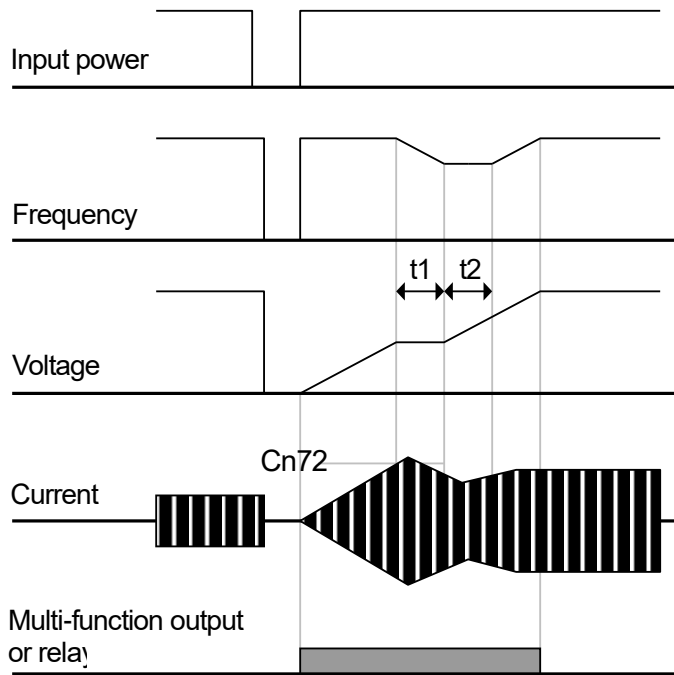

If an instantaneous power interruption occurs and the input power is disconnected, the inverter generates a low voltage trip and blocks the output.

When the input power returns, the operation frequency before the low voltage trip and the voltage is increased by the inverter's inner PI control.

t1: If the current increases above the value set at Cn72, the voltage stops increasing and the frequency decreases.

t2: If the current decreases below the value set at Cn72, the voltage increases again and the frequency stops decelerating.

When the normal frequency and voltage are resumed, the speed search operation accelerates the motor back to its frequency reference before the fault trip.

Speed search operation is suitable for loads with high inertia. When the load with high friction force occurs, stop and restart the inverter.

If operated within the rated output, the M100 series inverter is designed to withstand instantaneous power interruptions within 15 ms and maintain normal operation.

The DC voltage inside the inverter may vary depending on the output load. If the power interruption time is longer than 15 ms, a low voltage trip may occur. The instantaneous power interruption specification is applied when the input voltage is 200–240 VAC.

6.11 Auto Restart Settings

| Group | Code | Name | Parameter Setting | Setting Range | Initial Value | Unit |
|--------------------|------|------------------------------------|-------------------|---------------|---------------|-------|
| Pr (Protection) | 09 | Auto restart count | - | 0–10 | 0 | count |
| | 10 | Auto restart delay time after trip | - | 0.0–60.0 | 1.0 | sec |

Auto restart count can be set using the Pr09 code.

An auto restart is used to activate the inverter protection feature and protect the inverter from noise or other problems, therefore preventing the shutdown of the system.

Pr09: When a trip occurs and the run command is input after the trip, the inverter protection feature is activated and the inverter restarts automatically after the set time programmed at the Pr10 code. At each restart, the inverter counts the number of tries and subtracts it from the number set at the Pr09 code until the retry number count reaches 0. The retry number count returns to the original setting when you manually reset it using the inverter terminal block or the [STOP/RESET] key, and when a trip does not occur within 30 seconds after an auto restart.

If the inverter stops due to low voltage, emergency stop (Bx), inverter overheating, or hardware diagnosis, an auto restart is not activated.

The inverter start acceleration automatically after the auto restart delay time set by the Pr10 code. At auto restart, the acceleration options are identical to those of speed search operation (Cn71–74).

The following graph is an example when the auto restart count is set to 2.

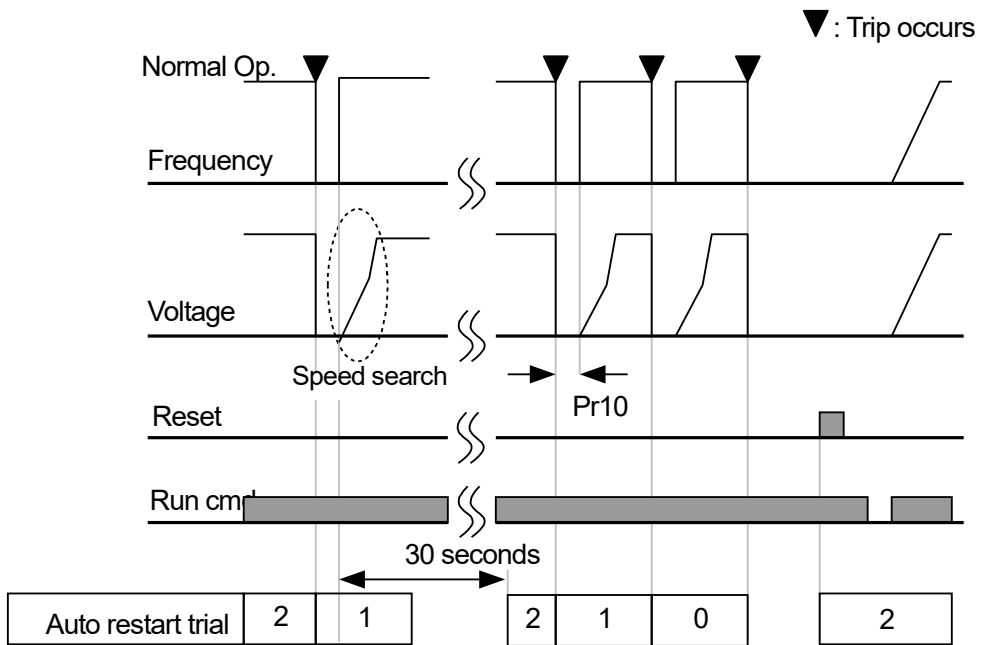

6.12 Operational Noise Settings (carrier frequency settings)

| Group | Code | Name | Parameter Setting | Setting Range | Initial Value | Unit |
|--------------|------|-------------------|-------------------|---------------|---------------|------|
| Cn (Control) | 04 | Carrier frequency | - | 1.0–15.0 | 3.0 | kHz |

An operational noise can be selected. There are pros and cons according to the operational noise volume as described in the table below.

| Code | Parameter Setting | Pros and Cons |
|------|------------------------|------------------------------------|
| Cn04 | High carrier frequency | Low motor noise |
| | | Increased heat loss |
| | | Increased inverter noise |
| | | Increased inverter leakage current |

6.13 2nd Motor Operation

The 2nd motor operation is used when a single inverter switch operates two motors with different type of loads. Note that this operation does not operate the two motors simultaneously.

| Group | Code | Name | Parameter Setting | Setting Range | Initial Value | Unit |
|---------------------------------------|------------------|-------------------------------------------------------------------|-------------------|-------------------------------------------------------------------|---------------|------|
| M2 (Secondary Motor) ¹⁾ | 04 | 2 nd motor acceleration time | - | 0.0–6000.0 | 5.0 | sec |
| | 05 | 2 nd motor deceleration time | - | 0.0–6000.0 | 10.0 | sec |
| | 07 | 2 nd motor base frequency | - | 30.00–Max freq. | 60.00 | Hz |
| | 12 | 2 nd motor rated current | - | 0.1–100.0 | - | A |
| | 25 | 2 nd motor V/F pattern | - | 0–2 | 0 | - |
| | 26 | 2 nd motor forward torque boost | - | 0.0–15.0 | 4.0 | % |
| M2 (Secondary Motor) ¹⁾ | 27 | 2 nd motor reversed torque boost | - | 0.0–15.0 | 4.0 | % |
| | 28 | 2 nd motor stall level | - | 30–150 | 150 | % |
| | 29 | 2 nd motor electric thermal 1 min level | - | 2nd motor electric thermal continuous operation level (M2-30)–200 | 150 | % |
| | 30 | 2 nd motor electric thermal continuous operation level | - | 50–2nd motor electric thermal 1 min level (M2-29) | 100 | % |
| In (Input Terminal) | 65 | Multi-function input terminal P1 function setting | - | 0–27 | 0 | - |
| | ~ | ~ | ~ | | ~ | ~ |
| | 69 ²⁾ | Multi-function input terminal P5 function setting | 12 | | 4 | - |

1) Available when one of the multi-function input terminal codes is set to 12 (Second motor selection).

2) For models equipped with standard I/O, you can set the parameter by In65–67 (Multi-function input terminal P1–P3).

Select a terminal to use as a second motor selection operation from the multi-function input terminals (standard I/O model: P1–P3, advanced I/O model: P1–P5) and set the corresponding code (In65–In69) to 12 (Second motor selection).

When the P5 terminal is selected, set the In69 code of the I/O Terminal groups to 12.

Select a motor between two motors connected to the inverter output terminals using the multi-function terminals. When the first motor stops, you can run the second motor by the M2-04–30 parameters and the second motor selection terminal input.

Input the signal to the second motor selection terminal after the motor stops.

The M2-04, M2-05, M2-07, M2-12, and M2-25–M2-30 codes are identical to the parameter function parameter.

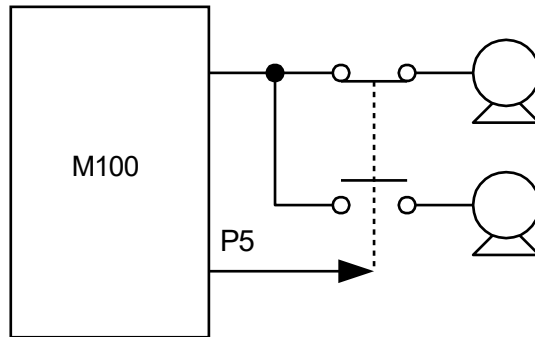

6.14 Frequency Setting and 2nd Operation Mode Setting

The 2nd operation mode enables switching the parameter setting of the frequency reference source and run command to the second parameter setting simultaneously using multi-function terminals. For example, you can stop using the remote control that is operated using the communication option and start control on the inverter unit.

| Group | Code | Name | Parameter Setting | Setting Range | Initial Value | Unit |
|---------------------|---------------------|-------------------------------------------------|-------------------|---------------|---------------|------|
| Operation | drv | 1 st Command source | - | 0–3 | 1 | - |
| | Frq | 1 st Frequency reference source | - | 0–11 | 0 | - |
| bA (Basic) | 04 ¹⁾ | 2 nd Command source | - | 0–3 | 1 | - |
| | 05 ¹⁾ | 2 nd Frequency reference source | - | 0–11 | 0 | - |
| In (Input Terminal) | 65–69 ²⁾ | Multi-function output terminal function setting | 22 | 0–27 | - | - |

1) Set one of the multi-function input terminal codes (standard I/O model: In65–67, advanced I/O model: In65–69) to 22 (2nd Source).

2) In68 and In69 are available only for models equipped with advanced I/O.

The 1st operation mode is an operation without a 2nd source input set by the multi-function input (In65–69).

Switching between the 1st and 2nd operations is enabled by turning ON/OFF the selected multi-function input terminal.

The command source and frequency reference source are set by the 1st operation mode when the multi-function terminal set as the 2nd operation mode is OFF. When the multi-function terminal is ON, the command source and frequency reference source are set by the 2nd operation mode.

The following table details for bA04 and bA05 setting of the 2nd operation mode. The setting method is the same as the 1st command source (drv) and the 1st frequency reference source (Frq).

| Code | Name | Parameter Setting | Description | |
|------|------------------------------|----------------------------------------------------------------------|------------------------------------------------------|-------------------------------------------------------------------------------------|
| bA04 | Command source 2 | 0 | Operation via the [RUN] and [STOP/RESET] keys | |
| | | 1 | Terminal block operation | FX: Forward operation command RX: Reverse operation command |
| | | 2 | | FX: Run command, stop command RX: Select rotation direction (forward or reverse) |
| | | 3 | Operation via the RS-485 communication ¹⁾ | |
| bA05 | Frequency reference source 2 | 0 | Digital | Keypad as digital frequency setting source 1 |
| | | 1 | | Keypad as digital frequency setting source 2 |
| | | 2 | Analog | Integrated volume operation: 0–5 [V] |
| | | 3 | | Terminal block's V1 terminal: 0–10 [V] |
| | | 4 | | Terminal block's I2 (I) terminal: 0–20 [mA] ¹⁾ |
| | | 5 | | Terminal block's I2(V) terminal: 0–10[V] ¹⁾ |
| | | 6 | | Integrated volume and terminal block I2 (I) ¹⁾ |
| | | 7 | | Integrated volume and terminal block I2 (V) ¹⁾ |
| | | 8 | Integrated volume and terminal block V1 | |
| | | 9 | Operation via the RS-485 communication ¹⁾ | |
| | | 10 | Up-down operation | |
| 11 | Analog | Integrated terminal block V1 and terminal block I2 (V) ¹⁾ | | |

1) Available only for models equipped with advanced I/O.

The following table details the operation settings when switching between the 1st operation mode and the 2nd operation mode.

| Group | Code | Name | Parameter Setting | Setting Range | Initial Setting | Unit |
|---------------------|------------------|-----------------------------------------------|-------------------|---------------|-----------------|------|
| Operation | drv | (1 st) Command source | 3 | 0–3 | 1 | - |
| | Frq | (1 st) Frequency reference source | 0 | 0–11 | 0 | - |
| bA (Basic) | 04 | 2 nd Command source | 1 | 0–3 | 1 | - |
| | 05 | 2 nd Frequency reference source | 0 | 0–11 | 0 | - |
| In (Input Terminal) | 69 ¹⁾ | Multi-function input P5 input terminal | 22 | 0–27 | 4 | - |

1) For models equipped with standard I/O, you can set the parameter by In65–67 (Multi-function input terminal P1–P3)

The operation is as shown in the graph below when the parameters are set as above, the command frequency is set to 30 Hz, and Ad08=0.

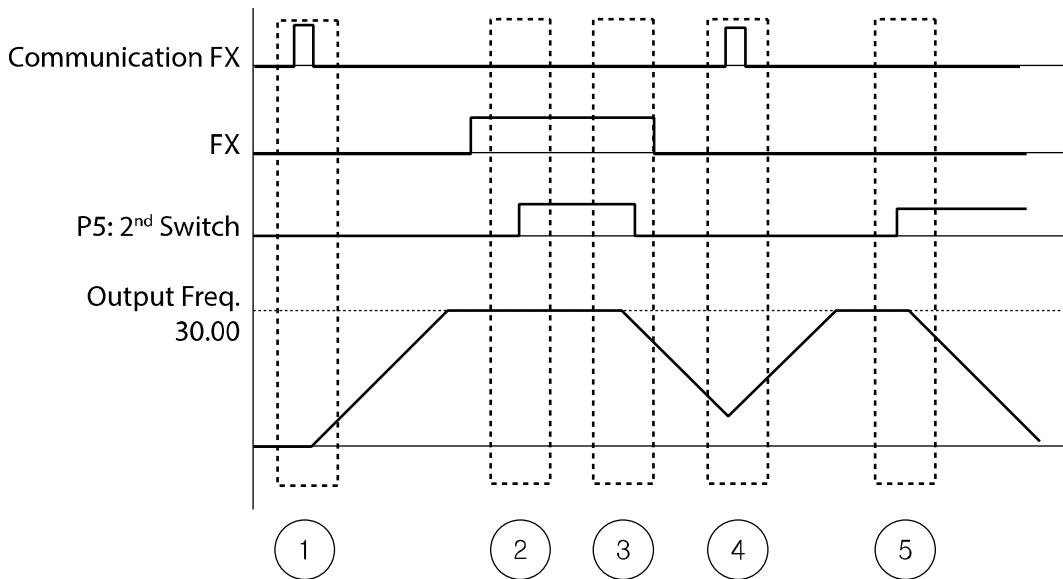

- ① Accelerates to the set frequency for the acceleration time by receiving the FX signal as the 1st operation command.
- ② The P5 terminal input is ON and the operation mode is switched to the 2nd operation mode. With the bA04 code set to Terminal operation 1, the inverter keeps operating while the FX terminal is ON.

- ③ The P5 terminal input is OFF and the operation mode is switched to the 1st operation mode. With the drv code set to the operation command, the inverter decelerates and stops according to the stop command.
- ④ With the communication FX signal (1st operation command) ON, the inverter accelerates to the set frequency.
- ⑤ The P5 terminal input is ON and the operation mode switches to the 2nd operation mode. With the bA04 code set to Terminal operation 1 and FX terminal set to OFF, the inverter decelerates and stops.

⚠ Caution

When setting the multi-function terminal (standard I/O model: P1–P3, advanced I/O model: P1–P5) is set to the 2nd command source (2nd Source) and input (ON) the signal, operation state is changed because the frequency setting and the Operation command will be changed to the 2nd command. Before shifting input to the multi-function terminal, ensure that the 2nd command is correctly set.

6.15 Input Voltage Setting

| Group | Code | Name | Parameter Setting | Setting Range | Initial Value | Unit |
|------------|------|------------------------|-------------------|---------------|---------------|------|
| bA (Basic) | 19 | Inverter input voltage | - | 170–240 | 220 | V |

The inverter input voltage can be set at the bA19 code.

The low voltage trip level is modified according to the input voltage.

6.16 Parameter Initialization

| Group | Code | Name | Parameter Setting | | Initial Value |
|-----------------------|------|--------------------------|-------------------|----------------------------|---------------|
| CF (Configuration) | 93 | Parameter initialization | 0 | Do not initialize | 0 |
| | | | 1 | Initialize all groups | |
| | | | 2 | Initialize Operation group | |
| | | | 3 | Initialize dr group | |
| | | | 4 | Initialize bA group | |
| | | | 5 | Initialize Ad group | |
| | | | 6 | Initialize Cn group | |
| | | | 7 | Initialize In group | |
| | | | 8 | Initialize OU group | |
| | | | 9 | Initialize CM group | |
| | | | 10 | Initialize AP group | |
| | | | 11 | Initialize Pr group | |
| | | | 12 | Initialize M2 group | |
| | | | 13 | Initialize CF group | |

Select a group to initialize and then execute the initialization at the CF93 code.

Set the parameter value at the CF93 code and press the [ENT] key. After the initialization is complete, CF93 is displayed again.

Password Registration

| Group | Code | Name | Parameter Setting | Setting Range | Initial Value | Unit |
|-----------------------|------|-----------------------|-------------------|---------------|---------------|------|
| CF (Configuration) | 94 | Password registration | - | 0000–FFFF | 0000 | - |
| | 95 | Parameter lock | - | 0000–FFFF | 0000 | - |

Register a password to prevent unauthorized modification of parameter settings (CF95). The password must be comprised of hexadecimal characters (0–9, A, b, C, d, E, F).

⚠ Caution

If you locked the parameter using a password, you must use the password to disable the parameter lock. Therefore, it is very important that you memorize the password.

The factory default password is '0000.' When first registering a password, enter any password except for '0000.'

Follow the instructions below when you first register a password.

| Step | Instruction | Keypad Display |
|------|----------------------------------------------|----------------|
| 1 | Go to the CF94 code. | CF94 |
| 2 | Press the [ENT] key twice. | 0000 |
| 3 | Register the password (for example, '0123'). | 0 123 |
| 4 | The password flashes. | 0 123 |
| 5 | Press the [ENT] key. | --CF94_ |

Follow the instructions below to change the password. The following example details changing the current password '0123' to a new password '0456.'

| Step | Description | Keypad Display |
|------|-----------------------------------------------------------------------------------------------------------------|----------------|
| 1 | Go to the CF94 code. | CF94 |
| 2 | Press the [ENT] key. | 0000 |
| 3 | Try entering different passwords from the current password (for example, '0122'), and then press the [ENT] key. | 0 122 |
| 4 | '0' is displayed when the wrong password is entered. You cannot change the password. | 0000 |
| 5 | Enter the correct current password. | 0 123 |
| 6 | Press the [ENT] key. | 0 123 |
| 7 | Enter a new password. | 0456 |
| 8 | Press the [ENT] key again. The new password will flash. | 0456 |
| 9 | Press the [ENT] key. | CF94 |

6.17 Parameter Lock

| Group | Code | Name | Parameter Setting | Setting Range | Initial Value | Unit |
|--------------------|------|-----------------------|-------------------|---------------|---------------|------|
| CF (Configuration) | 95 | Parameter lock | - | 0000–FFFF | 0000 | - |
| | 94 | Password registration | - | 0000–FFFF | 0000 | - |

Use parameter lock to prevent unauthorized modification of parameter settings. To enable parameter lock, register and enter a user password first.

Follow the instructions below to prevent unauthorized modification of parameter settings using the password registered at the CF94 code.

| Step | Instruction | Keypad Display |
|------|-------------------------------------------------------------------------|----------------|
| 1 | Go to the CF95 code. | CF95 |
| 2 | Press the [ENT] key. | UL |
| 3 | 'UL' (Unlock) is displayed when the parameter settings can be modified. | UL |
| 4 | Press the [ENT] key. | 0000 |
| 5 | Enter the value registered at the CF94 code (for example, '0123'). | 0 123 |

| Step | Instruction | Keypad Display |
|------|-------------------------------------------------------------------------|----------------|
| 6 | Press the [ENT] key. | L |
| 7 | 'L' (Lock) is displayed when the parameter settings cannot be modified. | L |
| 8 | Press the [ENT] key. | CF95 |

Follow the instructions below to disable parameter lock settings using the password registered at the CF94 code.

| Step | Instruction | Keypad Display |
|------|-------------------------------------------------------------------------|----------------|
| 1 | Go to the CF95 code. | CF95 |
| 2 | Press the [ENT] key. | L |
| 3 | 'L' (Lock) is displayed when the parameter settings cannot be modified. | L |
| 4 | Press the [ENT] key. | 0000 |
| 5 | Enter the value registered at the CF94 code (for example, '0123'). | 0 123 |
| 6 | Press the [ENT] key. | UL |
| 7 | 'UL' (Unlock) is displayed when the parameter settings can be modified. | UL |
| 8 | Press the [ENT] key. | CF95 |

6.18 Voltage Trip Prevention During Deceleration

Voltage trip prevention during deceleration uses regenerative brake force to prevent over voltage trips when the inverter decelerates or stops.

| Group | Code | Name | Parameter Setting | Setting Range | Initial Value | Unit |
|--------------------|------------------|-------------------------------------------------------------------|-------------------|---------------|---------------|------|
| Ad (Advanced) | 08 | Stop mode | 0 | 0-2 | 0 | - |
| Pr (Protection) | 50 | BIT 0 (-1): Stall protection during acceleration | - | 000-111 | 000 | Bits |
| | | BIT 1 (-1-): Stall protection while operating at a constant speed | | | | |
| | 53 ¹⁾ | Voltage limit during deceleration | 0 | 0-1 | 0 | - |

| Group | Code | Name | Parameter Setting | Setting Range | Initial Value | Unit |
|-------|------|--------------|-------------------|---------------|---------------|------|
| | | deceleration | | | | |

1) Pr53 (Voltage limit during deceleration) is available when BIT2 of the Pr50 code is set to 1.

To enable the over voltage trip during deceleration, set BIT2 of the Pr50 code to 1. The stall prevention during deceleration is enabled only during deceleration.

6.19 Brake Control

| Group | Code | Name | Parameter Setting | Setting Range | Initial Value | Unit |
|----------------------|------------------|-------------------------------------------------------------------------------------|-------------------|--------------------|---------------|------|
| dr (Drive) | 09 | Control mode | 0 | 0–2 | 1 | - |
| Ad (Advanced) | 41 ¹⁾ | Brake open current | - | 0.0–180.0 | 50.0 | % |
| | 42 ¹⁾ | Brake open delay time | - | 0.00–10.00 | 1.00 | sec |
| | 44 ¹⁾ | Brake open forward frequency | - | 0.00– Max freq. | 1.00 | Hz |
| | 45 ¹⁾ | Brake open reverse frequency | - | 0.00– Max freq. | 1.00 | Hz |
| | 46 ¹⁾ | Brake close delay time | - | 0.00–10.00 | 1.00 | sec |
| | 47 ¹⁾ | Brake close frequency | - | 0.00– Max freq. | 2.00 | Hz |
| OU (Output Terminal) | 31/ 32 | Multi-function relay function setting / Multi-function output 2 function setting | 19 | 0–19 | 17 | - |

1) Ad41, Ad42, and Ad44–47 are available when OU31 or OU32 is set to 19.

Brake control is used to control the On/Off operation of the electronic brake load system and is enabled only when the dr09 code is set to 0 (V/F steady control). Therefore, check the control mode first and then configure the sequence.

The DC braking and dwell operation are disabled at startup with the brake control enabled.

Brake release sequence

During motor stop state, if an operation command is entered, the inverter accelerates up to brake release frequency (Ad44– 45) in forward or in reverse direction. After reaching brake release frequency, if motor current reaches brake release current (Ad41), the output relay or multi-function output terminal for brake control sends a release signal. Once the signal has been sent, acceleration will begin after maintaining frequency for brake release delay time (Ad42).

Brake engage sequence

If a stop command is sent during operation, the motor decelerates. Once the output frequency reaches brake engage frequency (Ad47), the motor stops deceleration and sends out a brake engage signal to a preset output terminal. Frequency is maintained for the brake engage delay time (Ad46) and will become 0 afterwards.

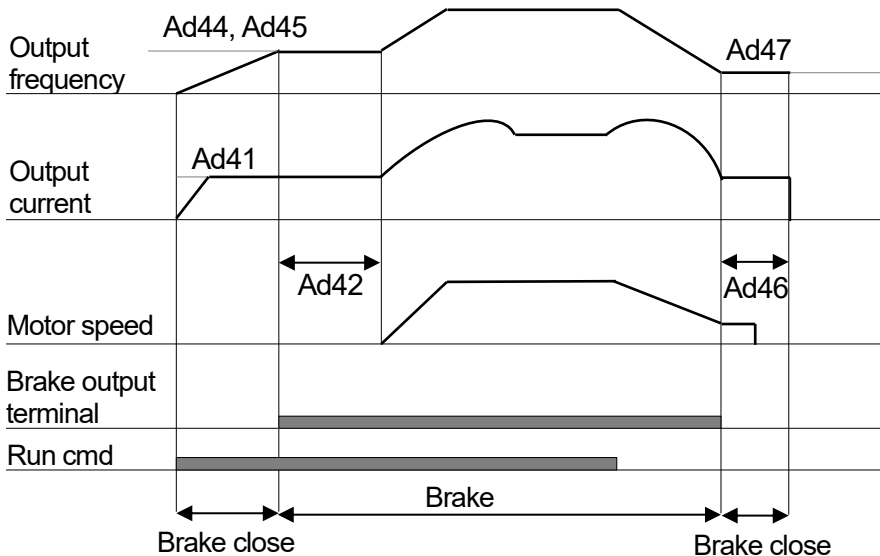

V/F Steady Control

⚠ Caution

The external brake control is used only when the control mode is set to V/F steady control and the brake open frequency is lower than the brake close frequency.

6.20 Analog Output

An output size can be adjusted by selecting an output option at the AO (Analog Output) terminal.

OU01: Outputs a selected output option in the following table at the AO (Analog Output) terminal.

| Group | Code | Name | Parameter Setting | Setting Range | Initial Value | Unit |
|----------------------|------|----------------------|-------------------|---------------|---------------|------|
| OU (Output Terminal) | 01 | Analog output option | - | 0-3 | 0 | - |
| | 02 | Analog output level | - | 10-200 | 100 | % |

| Code | Name | Parameter Setting | | Outputs for 10V |
|------|----------------------|-------------------|---------------------|------------------------------------|
| OU01 | Analog output option | 0 | Output frequency | Maximum frequency (FrM) |
| | | 1 | Output current | 150% of the inverter rated current |
| | | 2 | Output voltage | AC 282 V |
| | | 3 | Inverter DC voltage | DC 410 V |

OU02: Adjusts the analog output value based on various meters when an analog output is used as the input to the meter.

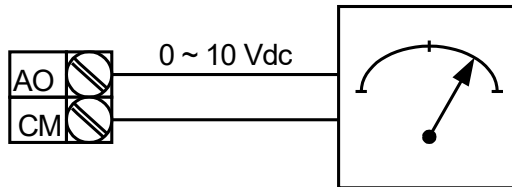

6.21 Digital Output

6.21.1 Multi-function Relay Output Terminal Settings

Set an output option for the inverter relay.

| Group | Code | Name | Setting Range | Initial Value | |
|-------------------------|-------------------------|-----------------------------------------------------------------|------------------------------------------------------------------|----------------------------------------|----|
| OU (Output Terminal) | 31 /32 ¹⁾ | Multi-function relay function /Multi-function output 2 function | 0 | FDT-1 | 17 |
| | | | 1 | FDT-2 | |
| | | | 2 | FDT-3 | |
| | | | 3 | FDT-4 | |
| | | | 4 | FDT-5 | |
| | | | 5 | Overload (OL) | |
| | | | 6 | Inverter overload (IOL) | |
| | | | 7 | Motor stall (STALL) | |
| | | | 8 | Over voltage trip (Ovt) | |
| | | | 9 | Low voltage trip (Lvt) | |
| | | | 10 | Inverter cooling pin overheat (OHt) | |
| | | | 11 | Lost command | |
| | | | 12 | RUN | |
| | | | 13 | Stop | |
| | | | 14 | Steady | |
| | | | 15 | Speed search | |
| | | | 16 | Ready | |
| | | | 17 | Trip output | |
| | | | 18 | Cooling fan abnormal condition warning | |
| | 19 | Brake control signal | | | |
| 30 ¹⁾ | Fault output | bit | 000–111 | 010 | |
| | | --1 | When the low voltage trip occurs | | |
| | | -1- | When a trip occurs except low voltage trip | | |
| | | 1-- | After a trip occurs while Pr09 (Auto restart count) has been set | | |

1) OU30: The multi-function output terminal and relay with the OU30 settings operate when the OU31 or OU32 code is set to 17 (Trip output).

Multi-function Relay Function/Multi-function Output 2 Function Setting Details

| OU31 (OU32) Parameter Setting | Description | | | | | | | | | | | | | | | | | | | | | | |
|------------------------------------------------------------------------------------------------------------------|-------------------------------------------------------------------------------------------------------------------------------------------------------------------------------------------------------------------------------------------------------------------------------------------------------------------------------------------------------------------------------------------------------------------------------------------------------------------------------------------------------------------------------------------|--------------------------|-------------------|---------------|-------------------|---------------|---------------|------|----------------------|----|--------------------------|---|---------------|-------|----|----|--------------------------|---|-------|--|--|--|--|
| 0 : FDT-1 | Detects inverter output frequency reaching the user set frequency. Outputs a signal when the absolute value (set frequency–output frequency) ≤ detected frequency width/2. | | | | | | | | | | | | | | | | | | | | | | |
| | <table border="1"> <thead> <tr> <th>Group</th> <th>Code</th> <th>Name</th> <th>Parameter Setting</th> <th>Setting Range</th> <th>Initial Value</th> <th>Unit</th> </tr> </thead> <tbody> <tr> <td>OU (Output Terminal)</td> <td>58</td> <td>Detection frequency band</td> <td>-</td> <td>0.00–Max frq.</td> <td>10.00</td> <td>Hz</td> </tr> </tbody> </table> | Group | Code | Name | Parameter Setting | Setting Range | Initial Value | Unit | OU (Output Terminal) | 58 | Detection frequency band | - | 0.00–Max frq. | 10.00 | Hz | | | | | | | | |
| Group | Code | Name | Parameter Setting | Setting Range | Initial Value | Unit | | | | | | | | | | | | | | | | | |
| OU (Output Terminal) | 58 | Detection frequency band | - | 0.00–Max frq. | 10.00 | Hz | | | | | | | | | | | | | | | | | |
| <p>When the OU58 code is set to 10.0, the FDT-1 output is as shown in the graph.</p> | | | | | | | | | | | | | | | | | | | | | | | |
| 1 : FDT-2 | Outputs a signal when the user set frequency and detected frequency (OU57) are equal, and fulfills FDT-1 condition at the same time. | | | | | | | | | | | | | | | | | | | | | | |
| | <p>(Set frequency = detected frequency) &[FDT-1]</p> <table border="1"> <thead> <tr> <th>Group</th> <th>Code</th> <th>Name</th> <th>Parameter Setting</th> <th>Setting Range</th> <th>Initial Value</th> <th>Unit</th> </tr> </thead> <tbody> <tr> <td rowspan="2">OU (Output Terminal)</td> <td>57</td> <td>Detection frequency</td> <td>-</td> <td rowspan="2">0.00–Max frq.</td> <td>30.00</td> <td rowspan="2">Hz</td> </tr> <tr> <td>58</td> <td>Detection frequency band</td> <td>-</td> <td>10.00</td> </tr> </tbody> </table> | Group | Code | Name | Parameter Setting | Setting Range | Initial Value | Unit | OU (Output Terminal) | 57 | Detection frequency | - | 0.00–Max frq. | 30.00 | Hz | 58 | Detection frequency band | - | 10.00 | | | | |
| Group | Code | Name | Parameter Setting | Setting Range | Initial Value | Unit | | | | | | | | | | | | | | | | | |
| OU (Output Terminal) | 57 | Detection frequency | - | 0.00–Max frq. | 30.00 | Hz | | | | | | | | | | | | | | | | | |
| | 58 | Detection frequency band | - | | 10.00 | | | | | | | | | | | | | | | | | | |
| <p>When the OU57, OU58 codes are set to 30 Hz and 10 Hz respectively, FDT-2 output is as shown in the graph.</p> | | | | | | | | | | | | | | | | | | | | | | | |

| OU31 (OU32) Parameter Setting | Description | | | | | | | | | | | | | | | | | | | | | |
|----------------------------------------------------------------------------------------------------------------------------------------------------------------------------------------------------------------------------------------------------------------------------------------------------------------------------------------------------------------------------------------------------------------------------------------------------------------------------------|----------------------------------------------------------------------------------------------------------------------------------------------------------------------------------------------------------------------------------------------------------------------------------------------------------------------------------------------------------------------------------------------------------------------------------------------------------------------------------|--------------------------|-------------------|-------------------|-------------------|---------------|---------------|----------------------|----------------------|---------------------|---------------------|---------------|---------------|-------|----|--------------------------|--------------------------|-------|-------|--|--|--|
| 2 : FDT-3 | Outputs a signal when the Absolute value (output frequency–operation frequency) ≤ detected frequency width/2. | | | | | | | | | | | | | | | | | | | | | |
| | <table border="1"> <thead> <tr> <th>Group</th> <th>Code</th> <th>Name</th> <th>Parameter Setting</th> <th>Setting Range</th> <th>Initial Value</th> <th>Unit</th> </tr> </thead> <tbody> <tr> <td rowspan="2">OU (Output Terminal)</td> <td>57</td> <td>Detection frequency</td> <td>-</td> <td rowspan="2">0.00–Max frq.</td> <td>30.00</td> <td rowspan="2">Hz</td> </tr> <tr> <td>58</td> <td>Detection frequency band</td> <td>-</td> <td>10.00</td> </tr> </tbody> </table> | Group | Code | Name | Parameter Setting | Setting Range | Initial Value | Unit | OU (Output Terminal) | 57 | Detection frequency | - | 0.00–Max frq. | 30.00 | Hz | 58 | Detection frequency band | - | 10.00 | | | |
| Group | Code | Name | Parameter Setting | Setting Range | Initial Value | Unit | | | | | | | | | | | | | | | | |
| OU (Output Terminal) | 57 | Detection frequency | - | 0.00–Max frq. | 30.00 | Hz | | | | | | | | | | | | | | | | |
| | 58 | Detection frequency band | - | | 10.00 | | | | | | | | | | | | | | | | | |
| When the OU57, OU58 codes are set to 30 Hz and 10 Hz respectively, FDT-3 output is as shown in the graph. | | | | | | | | | | | | | | | | | | | | | | |
| 3 : FDT-4 | Outputs a signal in the following conditions: | | | | | | | | | | | | | | | | | | | | | |
| | <ul style="list-style-type: none"> • In acceleration: Operation frequency ≥ Detected frequency • In deceleration: Operation frequency > (Detected frequency–Detected frequency width/2) | | | | | | | | | | | | | | | | | | | | | |
| <table border="1"> <thead> <tr> <th>Group</th> <th>Code</th> <th>Name</th> <th>Parameter Setting</th> <th>Setting Range</th> <th>Initial Value</th> <th>Unit</th> </tr> </thead> <tbody> <tr> <td rowspan="2">OU (Output Terminal)</td> <td>57</td> <td>Detection frequency</td> <td>-</td> <td rowspan="2">0.00–Max frq.</td> <td>30.00</td> <td rowspan="2">Hz</td> </tr> <tr> <td>58</td> <td>Detection frequency band</td> <td>-</td> <td>10.00</td> </tr> </tbody> </table> | Group | Code | Name | Parameter Setting | Setting Range | Initial Value | Unit | OU (Output Terminal) | 57 | Detection frequency | - | 0.00–Max frq. | 30.00 | Hz | 58 | Detection frequency band | - | 10.00 | | | | |
| Group | Code | Name | Parameter Setting | Setting Range | Initial Value | Unit | | | | | | | | | | | | | | | | |
| OU (Output Terminal) | 57 | Detection frequency | - | 0.00–Max frq. | 30.00 | Hz | | | | | | | | | | | | | | | | |
| | 58 | Detection frequency band | - | | 10.00 | | | | | | | | | | | | | | | | | |
| When the OU57, OU58 codes are set to 30 Hz and 10 Hz respectively, FDT-4 output is as shown in the graph. | | | | | | | | | | | | | | | | | | | | | | |

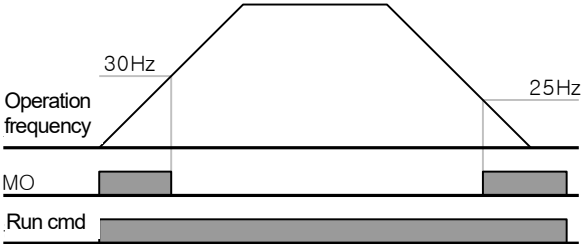
| OU31 (OU32) Parameter Setting | Description | | | | | | | | | | | | | | | | | | |
|------------------------------------------------|------------------------------------------------------------------------------------------------------------------------------------------------------------------------------------------------------------------------------------------------------------------------------------------------------------------------------------------------------------------------------------------------------------------------------------------------------------------------------------------------------------------------------------------------------------------------------------------------------------------------------------------------------------------------------------------------------------------------------------------------------------------------------------------------------------------------------------------------------------------------------------------------------------------------------------------------------------------------------------------------------------------------------------------------------------------------------------------|--------------------------|-------------------|-------------------|-------------------|---------------|---------------|------|----------------------|----|---------------------|---|-------------------|-------|----|----|--------------------------|---|-------|
| 4 : FDT-5 | <p>Outputs a signal to the B contact, in reverse to the FDT-4, in the following conditions:</p> <ul style="list-style-type: none"> • In acceleration: Operation frequency \geq Detected frequency • In deceleration: Operation frequency $>$ (Detected frequency – Detected frequency width/2) <table border="1" data-bbox="323 546 1230 774"> <thead> <tr> <th>Group</th> <th>Code</th> <th>Name</th> <th>Parameter Setting</th> <th>Setting Range</th> <th>Initial Value</th> <th>Unit</th> </tr> </thead> <tbody> <tr> <td rowspan="2">OU (Output Terminal)</td> <td>57</td> <td>Detection frequency</td> <td>-</td> <td rowspan="2">0.00– Max frq.</td> <td>30.00</td> <td rowspan="2">Hz</td> </tr> <tr> <td>58</td> <td>Detection frequency band</td> <td>-</td> <td>10.00</td> </tr> </tbody> </table> <p>When the OU57, OU58 codes are set to 30 Hz and 10 Hz respectively, FDT- 5 output is as shown in the graph.</p>  | Group | Code | Name | Parameter Setting | Setting Range | Initial Value | Unit | OU (Output Terminal) | 57 | Detection frequency | - | 0.00– Max frq. | 30.00 | Hz | 58 | Detection frequency band | - | 10.00 |
| Group | Code | Name | Parameter Setting | Setting Range | Initial Value | Unit | | | | | | | | | | | | | |
| OU (Output Terminal) | 57 | Detection frequency | - | 0.00– Max frq. | 30.00 | Hz | | | | | | | | | | | | | |
| | 58 | Detection frequency band | - | | 10.00 | | | | | | | | | | | | | | |
| 5 : Overload (OL) | Refer to 7.1.2 Overload Early Warning and Trip on page 161 . | | | | | | | | | | | | | | | | | | |
| 6 : Inverter overload (IOL) | Refer to 7.2.3 Inverter Overload Protection on page 165 . | | | | | | | | | | | | | | | | | | |
| 7 : Motor stall (STALL) | Refer to 7.1.3 Stall Prevention on page 162 . | | | | | | | | | | | | | | | | | | |
| 8 : Over voltage trip (Ovt) | Outputs a signal when the DC voltage of the inverter’s main circuit rises above the rated voltage (410 Vdc). | | | | | | | | | | | | | | | | | | |
| 9 : Low voltage trip (Lvt) | Outputs a signal when the DC voltage of the inverter’s main circuit drops under the rated voltage (initial value: 170 Vdc, determined by the bA19 setting) and a low voltage trip occurs. | | | | | | | | | | | | | | | | | | |
| 10 : Inverter cooling pin overheat (Oht) (Oht) | Outputs a signal when the inverter cooling pin overheats. | | | | | | | | | | | | | | | | | | |

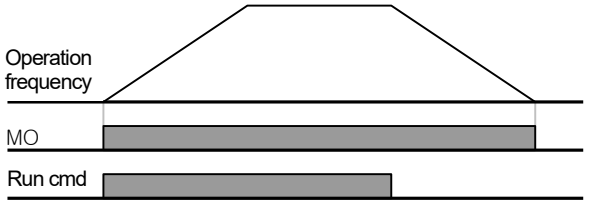
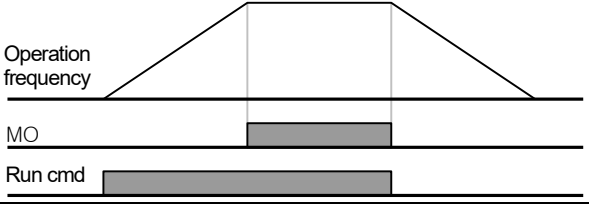
| OU31 (OU32) Parameter Setting | Description |
|-----------------------------------|----------------------------------------------------------------------------------------------------------------------------------------------------------------------------------------------------------------|
| 11 : Lost command | Outputs a signal when there is a loss of analog input (V0, V1 ,I2 ¹) input terminal and RS-485 communication command. |
| 12 : RUN | <p>Outputs a signal when operation command is entered and the inverter outputs voltage.</p>  |
| 13: Stop | Outputs a signal when the inverter does not run. |
| 14 : Steady | <p>Outputs a signal in steady operation.</p>  |
| 15 : Speed search | Refer to 6.10 Speed Search Operation on page 127 . |
| 16 : Ready | Outputs signal when the inverter is in stand by operation and ready to receive an external operation command. |
| 17 : Trip output | Outputs a signal according to the OU30 code settings. Example) If the OU31 code is set to 17, and the OU30 code is set to 2, the multi-function relay operates when a trip (except a low voltage trip) occurs. |
| 18 : Cooling fan abnormal warning | Outputs a signal when the Pr79 code is set to 0 (Continuous operation when cooling fan fault). Refer to 6.23 Operation Mode Setting When Cooling Fan is Abnormal on page 150 . |
| 19 : Brake control signal | Outputs a signal when the external brake signal is set. Refer to 6.19 Brake Control on page 140 . |

1) I2 input is available only for models equipped with advanced I/O.

6.22 Draw Operation

| Group | Code | Name | Parameter Setting | Setting Range | Initial Setting | Unit |
|---------------------|------|----------------|-------------------|---------------|-----------------|------|
| AP (Application) | 70 | Draw operation | - | 0–4 | 0 | - |
| | 71 | Draw ratio | - | 0.0–100.0 | 0.0 | % |

Draw operation is a tension control. This feature allows a constant tension to be applied to the material that is drawn by a motor-driven device, by fine-tuning the motor speed using operation frequencies that are proportional to a ratio of the main frequency reference.

The ratio applied to the output frequency differs by the AP70 (Draw operation) parameter setting.

| Code | Name | Parameter Setting | Function |
|------|----------------|-------------------|-----------------------------------------------------|
| AP70 | Draw operation | 0 | No draw operation |
| | | 1 | V1 (0–10 V) input draw operation |
| | | 2 | V0 (0–5 V) input draw operation |
| | | 3 | I2 (I) (0–20 mA) input draw operation ¹⁾ |
| | | 4 | I2 (V) (0–10 V) input draw operation ¹⁾ |

1) Available only for models equipped with advanced I/O.

Set the AP70 code to 1, 2, or 3.

If the input value is higher than the analog input's median value that is determined by the parameter settings of In08–11, In38–41, In53–56, and In58–61, the value is applied to the output frequency as a positive value, as much as the ratio set by AP71. If it is lower than the median value, it is applied as a negative value.

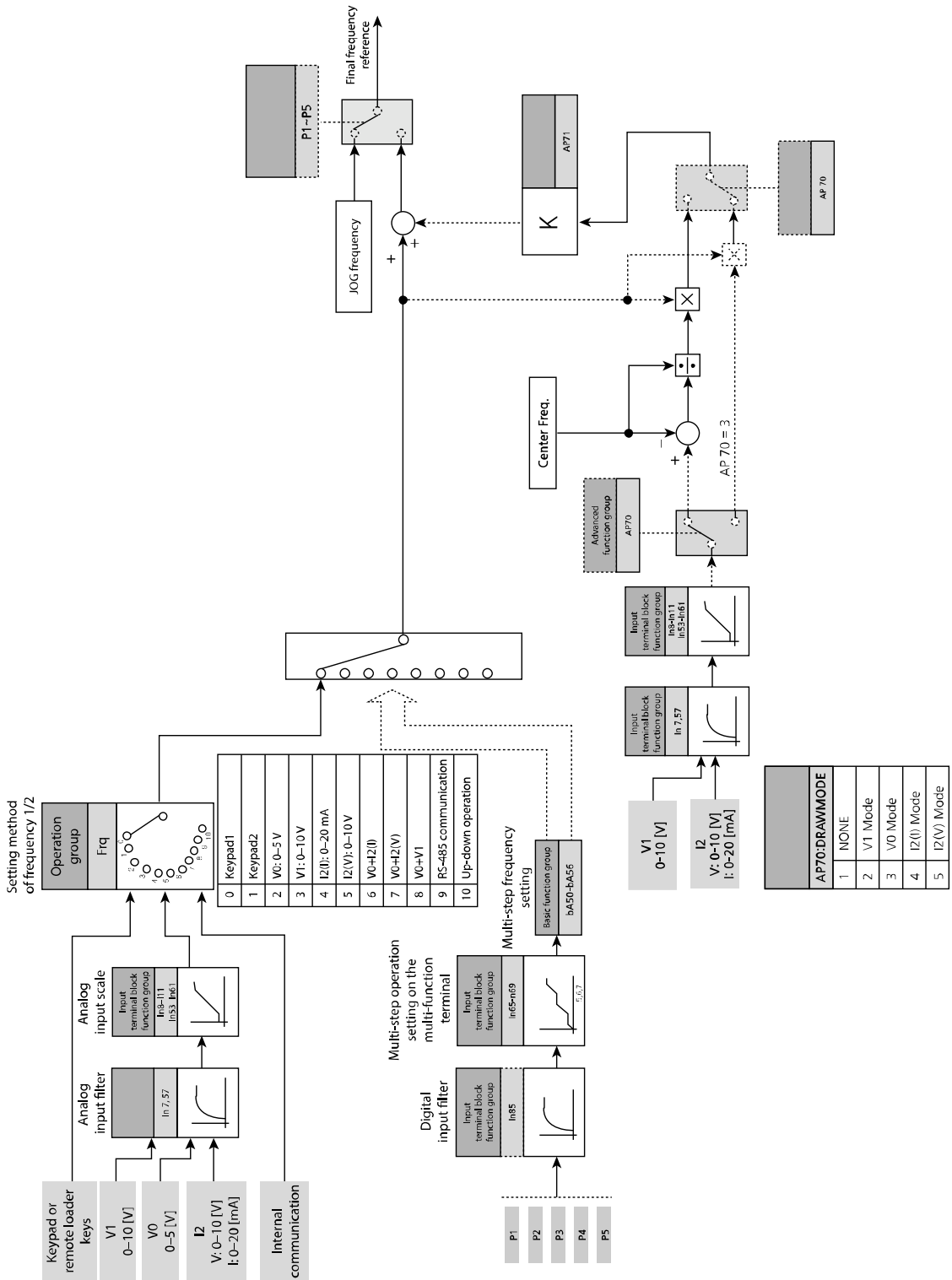

Example of Draw Operation

When the set frequency is 30 Hz, AP70=1(V1: 0–10 V), AP71=10.0%, and In07–In11 are set to the factory default settings, the frequency converted to the draw operation is 27 Hz (V1=0 V)–33 Hz (V1=10 V).

When the AP70 code is set to 1 (V1), the frequency is calculated by the following formula:

$$f'_{Ref} = f_{Ref} + \left\{ f_{ref} \times \frac{AP71}{100} \times \left(V_{in} - \frac{IN8 + IN10}{2} \right) \times \left(\frac{2}{IN10 - IN8} \right) \right\}$$

ⓘ Caution

- Set the operation command at the Frq/bA05 codes and other frequencies at the AP70 code (Draw operation).
- For example, the draw operation is disabled if Frq=3 (V1) and AP70=1 (V1).

6.23 Operation Mode Setting When Cooling Fan is Abnormal

| Group | Code | Name | Parameter Setting | Setting Range | Initial Setting | Unit |
|----------------------|-------|------------------------------------------------------------------------------------|-------------------|---------------|-----------------|------|
| Pr (Protection) | 79 | Cooling fan fault operation selection | - | 0–1 | 1 | - |
| OU (Output Terminal) | 31/32 | Multi-function relay function selection/Multi-function output 2 function selection | 18 | 0–19 | 17 | - |

Set the continuous operation or stop when a cooling fan fault occurs at the Pr79 code.

When the Pr79 code is set to 0 (Continuous operation when cooling fan fault), the warning signal is output at the OU31 code.

| Parameter Setting | Description |
|-------------------|-------------------------------------------------------------------------------------------------------------------------------------------------------------------------------------------------------------------------------------------------------------------------------------------------------------------------------------------------------------------------------------------------------------------------------------------------------------------------------------------------------------------------------------------------------------------------------------------------------------------------------------------------------------------------------------------------------------------------------------|
| Pr79 = 0 | <p>Sets continuous operation when a cooling fan fault occurs. The inverter does not stop and keeps operating.</p> <ul style="list-style-type: none"> A cooling fan fault signal can be output using the multi-function relay or multi-function output 2 terminal when the OU31 or OU32 code is set to 18 (Cooling fan warning signal). <p>⚠ Caution</p> <p>If you keep operating the inverter when a cooling fan fault occurs, the inverter cooling pin overheats and the cooling pin overheat protection may activate. Also, the lifespan of important components inside the inverter may be shortened by the rise of the internal temperature. Operate the inverter after fixing the cooling fan fault.</p> |
| Pr79 = 1 | <p>Set the operation to stop when a cooling fan fault occurs.</p> <ul style="list-style-type: none"> The keypad segment displays FAN and the inverter stops operation. A cooling fan fault signal can be output when the OU31 or OU32 code is set to 17 (Trip output). |

6.24 Operation State Monitor

Output Current

The inverter output current can be monitored by the CUr code in the Operation group.

| Group | Code | Name | Parameter Setting | Setting Range | Initial Value | Unit |
|-----------|------|----------------|-------------------|---------------|---------------|------|
| Operation | CUr | Output current | - | - | - | A |

Motor RPM

The motor RPM can be monitored by the rPM code in the Operation group.

| Group | Code | Name | Parameter Setting | Setting Range | Initial Value | Unit |
|------------------|------|-----------------------|-------------------|---------------|---------------|------|
| Operation | rPM | Motor RPM | - | - | - | rpm |
| bA (Basic) | 11 | Number of motor poles | - | 2-12 | 4 | - |
| AP (Application) | 01 | PID control selection | - | 0-1 | 0 | - |

| Group | Code | Name | Parameter Setting | Setting Range | Initial Value | Unit |
|---------------|------|------------------------|-------------------|---------------|---------------|------|
| Ad (Advanced) | 63 | Motor RPM display gain | - | 1~1,000 | 100 | % |

When the dr09 code is set to 0 (V/F control), the motor slip is not compensated and the inverter output frequency (f) is converted to rPM by the following formula:

$$rPM = \left(\frac{120 \times f}{bA11} \right) \times \frac{Ad63}{100 \%}$$

When the AP01 code is set to 1 (PID control), the volume of feedback is displayed as a frequency.

bA11: Inputs the number of motor poles on the motor rating plate.

Ad63: Inputs the motor RPM display gain with the gear rate involved when the motor system RPM is monitored rather than the motor shaft RPM.

DC Voltage of the Inverter Main Circuit

Monitor the DC voltage of the inverter's main circuit at the dCL code in the Operation group.

| Group | Code | Name | Parameter Setting | Setting Range | Initial Value | Unit |
|-----------|------|---------------------|-------------------|---------------|---------------|------|
| Operation | dCL | Inverter DC voltage | - | - | - | V |

The voltage multiplied by $\sqrt{2}$ of the inverter input voltage is displayed when the motor does not run.

User Select Signal Code Options

You can monitor an option set by the dr81 code in the Drive group at vOL.

If output power, torque, analog V1 terminal input, or analog I2 terminal input¹⁾ are selected, the vOL code display changes to POr, tOr, v1M, or I2M¹⁾ respectively.

| Group | Code | Name | Parameter Setting | Setting Range | Initial Value | Unit |
|------------|------|------------------------|-------------------|---------------|---------------|------|
| Operation | vOL | User select signal | - | - | - | V |
| dr (Drive) | 81 | Monitor code selection | - | 0 ~ 4 | 0 | - |

dr81: Set an option to display in the following table.

| Code | Name | Parameter Setting | Function | Output |
|------|------------------------|-------------------|-----------------------------------------------|--------|
| dr81 | Monitor code selection | 0 | Output voltage [V] | vOL |
| | | 1 | Output power [kW] | POr |
| | | 2 | Torque [kgf · m] | tOr |
| | | 3 | Analog V1 terminal input [V] | v1M |
| | | 4 | Analog I2 terminal input [mA/V] ¹⁾ | I2M |

1) Analog I2 terminal and I2M are available only for models equipped with advanced I/O. A current mode and voltage mode are switched by operating SW2, and the current is displayed up to 20 mA and the voltage up to 10 V when current is input.

For the display accuracy of torque, enter the motor efficiency on the motor rating plate at the bA15 code.

Range Selection At Power Input

An option set by the CF01 code in the Configuration group is displayed when power is input. When the parameters 12–15 are set, output current, motor RPM, DC voltage, and user select signal are displayed.

| Group | Code | Name | Setting Range | | Initial Value |
|-----------------------|---------------------------|------------------------------|---------------|----------------------------------|---------------|
| CF (Configuration) | 01 | Select ranges at power input | 0 | Run frequency (0.00) | 0 |
| | | | 1 | Acceleration time (ACC) | |
| | | | 2 | Deceleration time (dEC) | |
| | | | 3 | Command source (drv) | |
| | | | 4 | Frequency reference source (Frq) | |
| | | | 5 | Motor selection (MkW) | |
| | | | 6 | Motor rated current (MrC) | |
| | | | 7 | Base frequency (MbF) | |
| | | | 8 | Maximum frequency (FrM) | |
| | | | 9 | Output voltage setting (IOv) | |
| | | | 10 | Forward torque boost (Ftb) | |
| | | | 11 | Reverse torque boost (rtb) | |
| | | | 12 | Output current (Cur) | |
| | | | 13 | Motor RPM (rPM) | |
| 14 | Inverter DC voltage (dCL) | | | | |

| Group | Code | Name | Setting Range | | Initial Value |
|-------|------|------|---------------|---------------------------|---------------|
| | | | 15 | User select signal | |
| | | | 16 | Out of order signal (nOn) | |
| | | | 17 | Open hidden group (OGr) | |

6.25 I/O Terminal Block State Monitor

Input Terminal Block State Monitor

Monitor a current ON or OFF state of the input terminal block by the In90 code in the Input Terminal group.

| Group | Code | Name | Parameter Setting | Setting Range | Initial Value | Unit |
|---------------------|------|----------------------------------|-------------------|--------------------------------------------|---------------|------|
| In (Input Terminal) | 90 | Input monitor block state signal | - | 000-111(Standard) 00000-11111(Advanced) | - | Bits |

When the input terminal P1, P3, and P4 are ON, the keypad segment is displayed as the following:

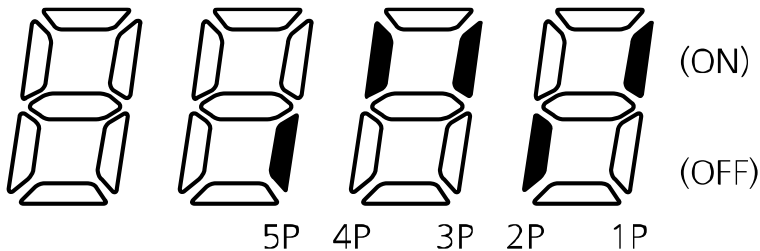

※ Only 1P-3P are available for models equipped with standard I/O.

Output Terminal Block State Monitor

Monitor a current ON or OFF state of the multi-function relay and the open collector output by the OU41 code in the Output Terminal group.

| Group | Code | Name | Parameter Setting | Setting Range | Initial Value | Unit |
|----------------------|------|-----------------------------------|-------------------|---------------|---------------|------|
| OU (Output Terminal) | 41 | Output monitor block state signal | - | 00–11 | 00 | Bits |

When the multi-function relay 1 is ON and the open collector output (standard I/O) is OFF, the keypad segment is displayed as the following:

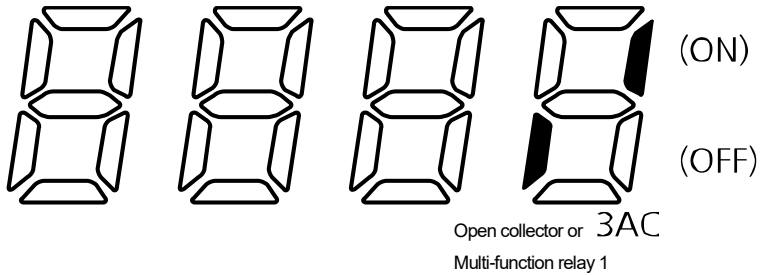

6.26 Fault State Monitor

Current Fault state Monitor

The nOn code in the Operation group displays a fault type when a trip occurs during the operation.

| Group | Code | Name | Parameter Setting | Setting Range | Initial Value | Unit |
|-----------|------|---------------------|-------------------|---------------|---------------|------|
| Operation | nOn | Out of order signal | - | - | - | - |

When a trip occurs, you can view the information for the fault type and the inverter operation state, fault type, frequency, current, and acceleration/deceleration information sequentially. Refer to [3 Learning to Perform Basic Operations](#) on page [39](#) for more information about how to use the keypad.

| Item | Display Example | |
|---------------------------------------|-----------------|-----------------------------------|
| Frequency | | |
| Current | | |
| Acceleration/Deceleration information | | Trip occurred during acceleration |
| | | Trip occurred during deceleration |
| | | Trip occurred at constant speed |

Refer to [10.1 Trips](#) on page [217](#) for more information about trip types.

Fault History Monitor

Pr91–95: Saves information for up to 5 fault trips that occur during operation.

Pr96: Clears all information for the fault trips saved at the Pr91–95 codes.

| Group | Code | Name | Parameter Setting | Setting Range | Initial Value | Unit |
|--------------------|------|------------------------|-------------------|---------------|---------------|------|
| Pr (Protection) | 91 | Fault history 1 | - | - | nOn | - |
| | ~ | ~ | ~ | ~ | ~ | ~ |
| | 95 | Fault history 5 | - | - | nOn | - |
| | 96 | Fault history deletion | - | 0–1 | 0 | - |

Information of the current fault trip can be monitored by the nOn code in the Operation group when a trip occurs during operation.

When you reset the inverter to clear the fault status by using the [STOP/RESET] key or a multi-function terminal block, the information displayed by the Operation group is moved to the Pr91 code. At this time, the previous fault information saved at the Pr91 code is moved to the Pr92 code automatically. Therefore, the most recent trip information is saved in the lowest fault history codes.

If multiple trips occur at the same time, the trip information is saved at a single code in a sequential order.

The following example details navigating to a different code after viewing a fault.

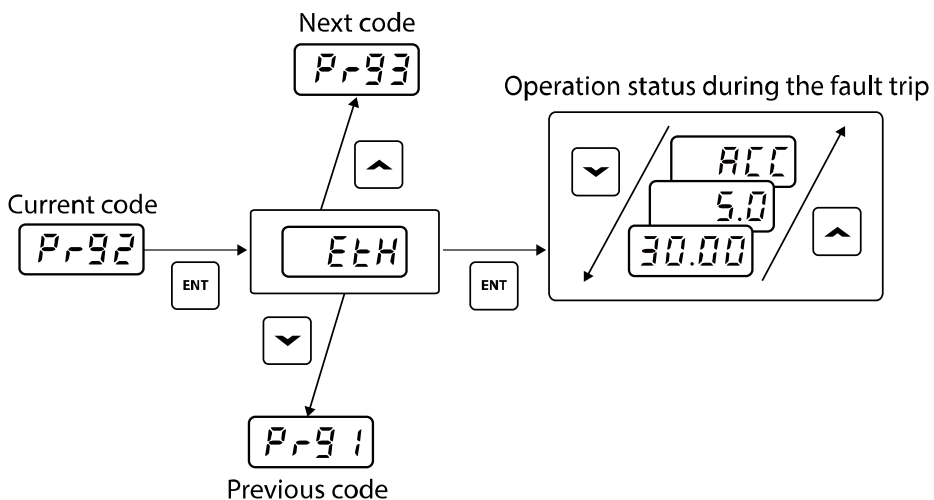

7 Learning Protection Features

7.1 Motor Protection

7.1.1 Electronic Thermal Motor Overheating Prevention (ETH)

Set the Pr40 code to 1.

This feature is to protect motor from overheating based on inverse time-limit thermal characteristics. The inverter output is blocked based on the ETH trip time in the figure below when the current exceeds the value set at the Pr42 code.

| Group | Code | Name | Parameter Setting | Setting Range | Initial Value | Unit |
|--------------------|--------------------|-----------------------------------------------|-------------------|---------------------------------------------------|---------------|------|
| Pr (Protection) | 40 | Electronic thermal selection | 1 | 0–1 | 0 | - |
| | 42 ¹⁾ | Electronic thermal 1 minute level | - | Electronic thermal continuous operation level–200 | 150 | % |
| | 43 ¹⁾²⁾ | Electronic thermal continuous operation level | - | 50– Electronic thermal 1 minute level | 100 | % |
| | 41 ¹⁾ | Motor cooling style | - | 0–1 | 0 | - |

1) Displayed only when Pr40 is set to 1.

2) The value cannot be set to 150% or more.

Pr42: Enter the motor's maximum current per minute based on the motor-rated current. The value cannot be set under the value set at Pr43.

Pr43: Enter the current to continuously operate the motor at. Generally, the value is the rated current that is specified on the motor's rating plate. The value cannot be set to the value set at Pr42, 150%, or more than the values.

Pr4: The cooling effect of general induction motors differs depending on the revolutions because cooler is attached to the motor's axis. But some motors, such as vector induction motors, supply separate power to the cooler to get a better cooling effect at low speeds.

| Code | Name | Parameter Setting | Description |
|--------------------|---------------------|-------------------|---------------------------------------------------|
| Pr41 ¹⁾ | Motor cooling style | 0 | General motor that cooler is attached to its axis |
| | | 1 | Motor that supplies separate power to the cooler |

1) Displayed only when Pr40 is set to 1.

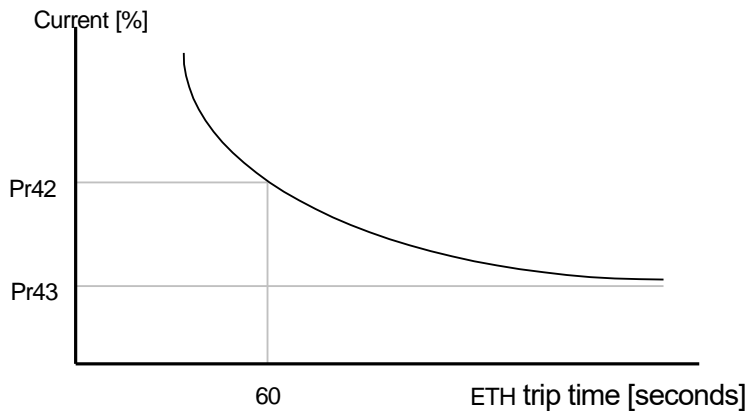
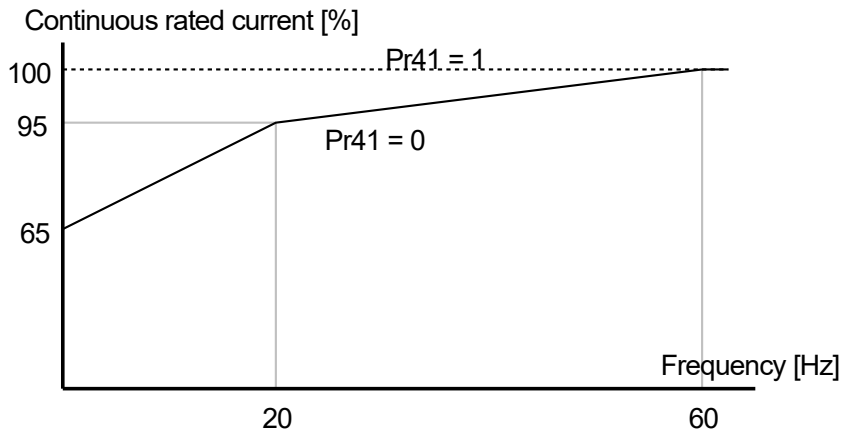

7.1.2 Overload Early Warning and Trip

Set the OU31 code in the Input/output group to 5. (Overload: OL)

| Group | Code | Name | Parameter Setting | Setting Range | Initial Value | Unit |
|----------------------|------------------|--------------------------------------------------------------------------------------|-------------------|---------------|---------------|------|
| Pr (Protection) | 18 ¹⁾ | Overload warning level | - | 30–150 | 150 | % |
| | 19 | Overload warning time | - | 0.0–30.0 | 10.0 | s |
| OU (Output Terminal) | 31/32 | Multi-function relay feature selection/ Multi-function output 2 feature selection | 5 | 0–19 | 17 | - |

1) Set this value based on the motor-rated current (MrC).

t: Overload warning time

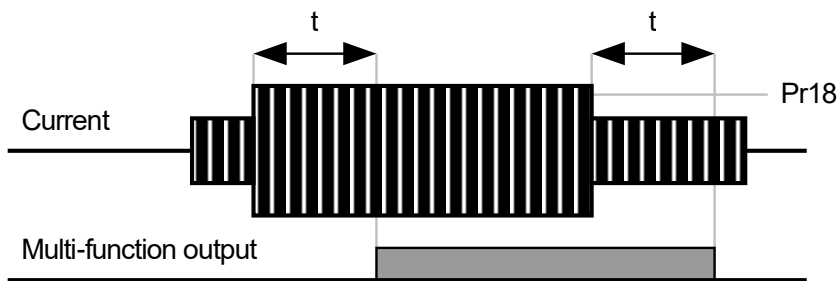

Overload trip

| Group | Code | Name | Parameter Setting | Setting Range | Initial Value | Unit |
|-----------------|------------------|-------------------------|-------------------|---------------|---------------|------|
| Pr (Protection) | 20 | Overload trip selection | 1 | 0–1 | 1 | - |
| | 21 ¹⁾ | Overload trip level | - | 30–200 | 180 | % |
| | 22 ¹⁾ | Overload trip time | - | 0.0–60.0 | 60.0 | s |

1) Displayed only when Pr20 (Overload warning selection) is set to 1.

Set the Pr20 code in the Protection (Pr) group to 1.

This feature is to block inverter output when the motor is overloaded.

The output is blocked when the current level exceeds the set value during the overload trip time.

When using the automatic restart function and the overload trip time is more than 30 seconds, the number of automatic restarts after a fault trip is initialized, even if the fault trip occurs 30 seconds after operation with a load that exceeds the overload trip level is started.

7.1.3 Stall Prevention

When accelerating: The motor decelerates when the current exceeds the value set at the Pr52 code.

When operating at a constant speed: The motor decelerates when the current exceeds the value set at the Pr52 code.

When decelerating: The motor stops decelerating when the voltage of the internal DC circuit increases to a certain level.

Pr52: Set this value based on the motor-rated current (MrC).

OU31/OU32: The motor stall status can be output to the connected external devices using the inverter's multi-function relay (3ABC). (The status is output whenever the motor is stalled, regardless of the stall prevention (Pr50) setting).

| Group | Code | Name | Parameter Setting | Setting Range | Initial Value | Unit |
|----------------------|-----------|--------------------------------------------------------------------------------------|-------------------|---------------|---------------|------|
| Pr (Protection) | 50 | Stall prevention selection | - | 000–111 | 000 | Bit |
| | 52 | Stall prevention level | - | 30–200 | 150 | % |
| OU (Output Terminal) | 31/ 32 | Multi-function relay feature selection/ Multi-function output 2 feature selection | 7 | 0–19 | 17 | - |

Pr50: Refer to the following table to configure the stall prevention setting.

| Code | Name | bit | Settings |
|------|----------------------------|-----|-------------------------------|
| Pr50 | Stall prevention selection | --1 | Accelerating |
| | | -1- | Operating at a constant speed |
| | | 1-- | Decelerating |

Example) Set the Pr50 code to 011 to use stall prevention during acceleration and operating at a constant speed.

When stall prevention is activated, the acceleration and deceleration times become longer than the set times because the motor decelerates during acceleration and stops decelerating during deceleration.

When using the t1 or t2 stall prevention settings during the steady operation, the motor accelerates and decelerates based on the acceleration time (ACC) and deceleration time (dEC) set at the operation group.

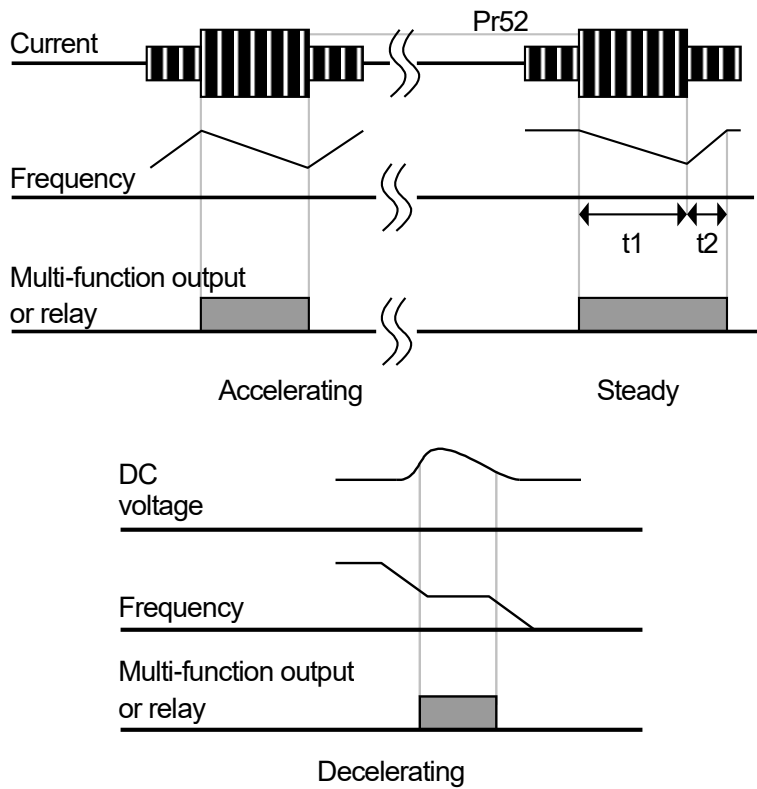

7.2 Inverter and Sequence Protection

7.2.1 Output Open-phase Protection

Set the Pr05 code in the protection (Pr) group to 1.

Output open-phase: The inverter output is blocked when one of the 3 phases (U, V, W) of inverter becomes an open phase.

| Group | Code | Name | Parameter Setting | Setting Range | Initial Value | Unit |
|--------------------|------|----------------------------------------|-------------------|---------------|---------------|------|
| Pr (Protection) | 05 | Output open-phase protection selection | 1 | 0-1 | 0 | - |

⚠ Caution

Set the motor-rated current (MrC) correctly. The output open-phase protection function may not operate if the MrC code value does not match the actual motor-rated current.

| Code | Name | Parameter Setting | Description |
|------|----------------------------------------|-------------------|-------------------------------------------------------|
| Pr05 | Output open-phase protection selection | 0 | Set not to use output open-phase protection selection |
| | | 1 | Set to use output open-phase protection |

7.2.2 External Trip Signal

Select a terminal to use as the external trip signal between the multi-function input terminals (standard I/O model: P1–P3, advanced I/O model: P1 – P5).

If you want to use P4 as the external trip signal for terminal A and P5 as external trip signal terminal B, set the In68 code to 18 and the In69 code to 19.

| Group | Code | Name | Parameter Setting | Setting Range | Initial Value | Unit |
|---------------------|------------------|---------------------------------------------------|-------------------|---------------|---------------|------|
| In (Input Terminal) | 65 | Multi-function input terminal P1 function setting | - | 0–27 | 0 | - |
| | – | – | – | | – | – |
| | 68 ¹⁾ | Multi-function input terminal P4 function setting | 18 | | 3 | - |
| | 69 ¹⁾ | Multi-function input terminal P5 function setting | 19 | | 4 | - |

1) The In68 and In69 (multi-function input terminal P4–P5) codes are available only for models equipped with advanced I/O. When using models equipped with standard I/O, use In65–67 (multi-function input terminal P1–P3).

External trip signal input terminal A (N.O.): Maintains open status between the P4 and CM terminals for normal statuses and blocks output when a short circuit occurs.

External trip signal input terminal B (N.C.): Maintains short circuit status between the P5 and CM terminals for normal statuses and blocks output when the circuit is open.

(The trip by the external trip signal input terminal B (Etb) cannot be cleared if the P5 function is changed after the trip occurs. Short-circuit the P5 and CM to clear the trip first and change the function.)

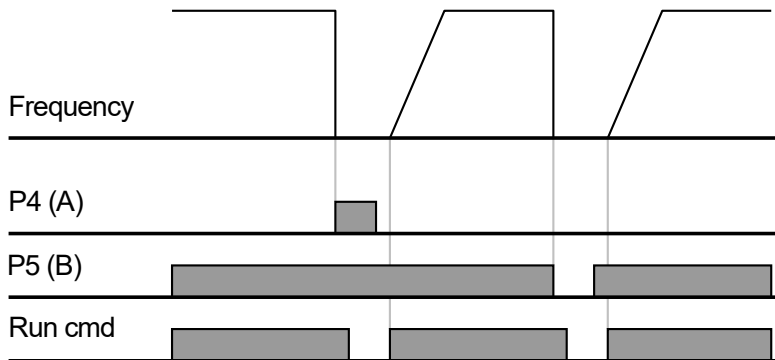
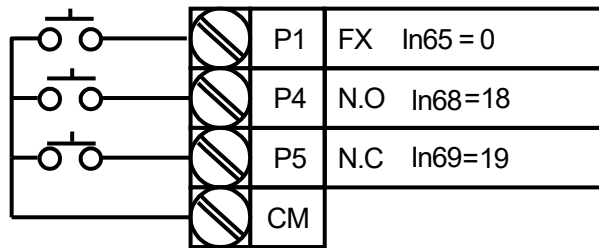

7.2.3 Inverter Overload Protection

| Group | Code | Name | Parameter Setting | Setting Range | Initial Value | Unit |
|----------------------|-----------|--------------------------------------------------------------------------------------|-------------------|---------------|---------------|------|
| OU (Output Terminal) | 31/ 32 | Multi-function relay feature selection/ Multi-function output 2 feature selection | 6 | 0–19 | 17 | - |

Protection Features

When the inverter input current exceeds the rated current, a protective function is activated to prevent damages to the inverter based on inverse proportional characteristics.

The multi-function relay (3ABC) signal can be output to the connected external devices when an inverter overload trip occurs.

7.2.4 Speed Command Loss

When setting operation speed using an analog input at the terminal block or communication options, speed command loss setting can be used to select the inverter operation for situations when the speed command is lost due to the disconnection of signal cables.

| Group | Code | Name | Parameter Setting | Setting Range | Initial Value | Unit |
|----------------------|-----------|--------------------------------------------------------------------------------------|-------------------|---------------|---------------|------|
| Pr (Protection) | 15 | Select loss criteria for analog speed command | 0 | 0–2 | 0 | - |
| | 12 | Motion at speed command loss | - | 0–2 | 0 | - |
| | 13 | Time to determine speed command loss | - | 0.1–120.0 | 1.0 | s |
| OU (Output Terminal) | 31/ 32 | Multi-function relay feature selection/ Multi-function output 2 feature selection | 11 | 0–19 | 17 | - |

Pr15: Select loss criteria for analog speed command

| Code | Name | Parameter Setting | Description |
|------|-----------------------------------------------|-------------------|-----------------------------------------------------------------------------------------------|
| Pr15 | Select loss criteria for analog speed command | 0 | Not operating |
| | | 1 | When the input value is less than the half of the value set at the In 8, In38, and In53 codes |
| | | 2 | When the input value is less than the value set at the In 8, In38, and In53 codes |

Example 1) If the speed command is set to 3 (terminal block V1) at the Frq code in the operation group and Pr15 is set to 1, it is determined to be a speed command loss when the V1 input value is less than the half of the value set at In08.

Example 2) If the speed command is selected to 6 (advanced I/O only, terminal block V0+I2 (I)) at the Frq code in the operation group and Pr15 is set to 2, it is determined to be a speed command loss when the V0 input value is less than the value set at In38 or the input of the I2(I) terminal is less than the value set at In53.

Pr12: The inverter operates based on the Pr12 setting if conditions meet the Pr15 setting during the time set at Pr13.

| Code | Name | Parameter Setting | Description |
|------|------------------------------|-------------------|------------------------------------------------------|
| Pr12 | Motion at speed command loss | 0 | Continue to run at frequency before the command loss |
| | | 1 | Free run stop (output block) |
| | | 2 | Deceleration stop |

OU31 (or OU32): The information about the speed command loss can be output to connected external devices using the multi-function relay (3ABC) or multi-function output 2.

Example) When the Pr15 cod is set to 2, the Pr12 code is set to 2, the Pr13 code is set to 5.0 seconds, and the OU31 code is set to 11

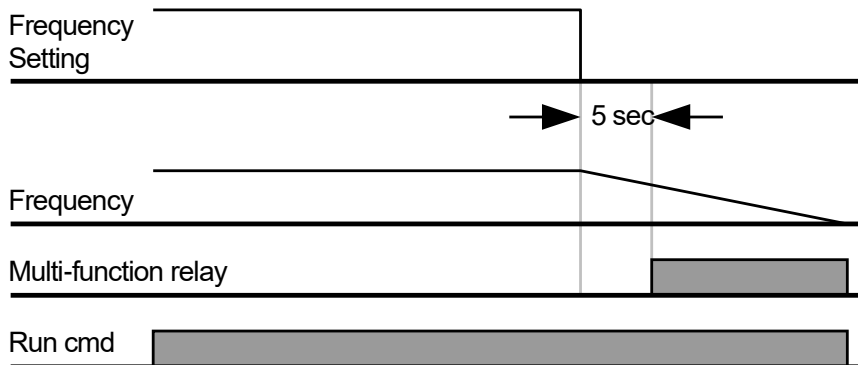

7.2.5 Dynamic Braking (DB) Resistor Configuration

Set the Pr65 code to 1.

| Code | Name | Parameter Setting | Description |
|------|-----------------------------------|-------------------|---------------------------------------------|
| Pr65 | DB resistor warning level setting | 0 | Use DB resistor without level limit |
| | | 1 | Use DB resistor during the time set at Pr66 |

Set the level (%ED: Enable Duty) at Pr66.

| Group | Code | Name | Parameter Setting | Setting Range | Initial Value | Unit |
|-----------------|------------------|-----------------------------------|-------------------|---------------|---------------|------|
| Pr (Protection) | 65 | DB resistor warning level setting | 1 | 0–1 | 1 | - |
| | 66 ¹⁾ | DB resistor warning level | - | 0–30 | 10 | % |

1) Displayed only when Pr65 (DB resistor warning level limit setting) is set to 1.

⚠ Caution

Do not set the braking resistor to exceed the resistor's power rating (Watt). If overloaded, it can overheat and cause a fire. When using a resistor with a heat sensor, the sensor output can be used as an external trip signal for the inverter's multi-function input.

Braking resistor configuration sets the rate at which the braking resistor operates for one operation cycle. The maximum time for continuous braking is 15 sec and the braking resistor signal is not output from the inverter after the 15 sec period has expired. An example of braking resistor set up is as follows:

Example 1)
$$\text{Pr } 66 = \frac{T_{dec}}{T_{acc} + T_{steady} + T_{dec} + T_{stop}} \times 100 [\%]$$

T_{acc} : Acceleration time to set frequency

T_{steady} : Constant speed operation time at set frequency

T_{dec} : Deceleration time to a frequency lower than constant speed operation or the stop time from constant speed operation frequency

T_{stop} : Stop time until operation resumes

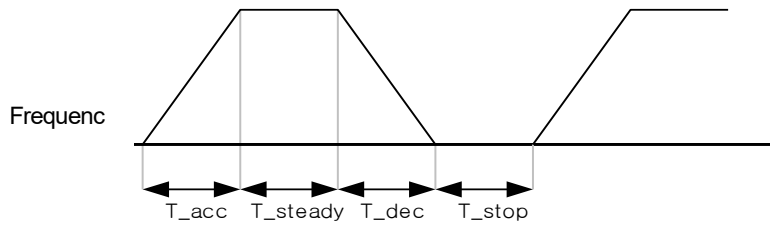

Example 2) $Pr\ 66 = \frac{T_{dec}}{T_{dec} + T_{steady1} + T_{acc} + T_{steady2}} \times 100 [\%]$

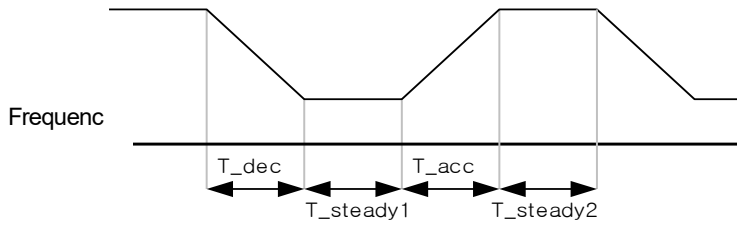

7.2.6 Initial charging circuit trip(ROT)

Set the Pr80 code to 1.

| Code | Name | Parameter Setting | Description |
|------|------------------------------------------|-------------------|----------------------|
| Pr80 | Initial charging circuit trip protection | 0 | Not use ROT function |
| | | 1 | Use ROT function |

Initial charging circuit : The initial charging circuit limits the inrush current when supplying power to the inverter, and it consists of a resistor and a relay.

| Group | Code | Name | Parameter Setting | Setting Range | Initial Value | Unit |
|-----------------|------|------------------------------------------|-------------------|---------------|---------------|------|
| Pr (Protection) | 80 | Initial charging circuit trip protection | 1 | 0–1 | 1 | bit |

⚠ Caution

The initial charging circuit trip protection function can be used only when input power is 0.4–2.2 kW, and it does not protect trips due to a relay fusion. This function activates and protects the inverter when the input power is unstable or an initial charging circuit trip occurs while supplying power to the inverter. If the ROT continues to occur after turning the power off and on again, stop using the inverter and contact the retailer or the LS ELECTRIC customer service center. (The inverter may become damaged if you operate the inverter in an initial charging circuit trip status.)

8 RS-485 Communication Features

This section in the user manual explains how to control the inverter with a PLC or a computer over a long distance using the RS-485 communication features. RS-485 communication features are available only for M100 models equipped with advanced I/O. To use the RS-485 communication features, connect the communication cables and set the communication parameters on the inverter. Refer to the communication protocols and parameters to configure and use the RS-485 communication features.

8.1 Communication Standards

Following the RS-485 communication standards, M100 products exchange data with a PLC and computer. The RS-485 communication standards support the Multi-drop Link System and offer an interface that is strongly resistant to noise. Please refer to the following table for details about the communication standards.

| Item | Standard |
|------------------------------------------------------------|------------------------------------------------------------------------------------------|
| Communication method/ Transmission type | RS-485/Bus type, Multi-drop Link System |
| Inverter type name | M100 |
| Number of connected inverters/ Transmission distance | Maximum of 16 inverters / Maximum 1,200m (recommended distance: within 700m) |
| Recommended cable size | 2 Pair Shielded Twisted Pair Cable (keep it a safe distance from the power cable.) |
| Installation type ¹⁾ | RJ45 connector (pin 1: S+, pin 8: S-) on the I/O board |
| Power supply | Supplied by the inverter– an insulated power source from the inverter's power circuit |
| Communication speed | 1,200/ 2,400/ 4,800/ 9,600/ 19,200/ 38,400 bps |
| Control procedure | Asynchronous communications system |
| Communication system | Half duplex system |
| Character system | Modbus-RTU: Binary / LS INV 485: ASCII |

| Item | Standard |
|-------------------|---------------|
| Stop bit length | 1-bit/2-bit |
| Frame error check | 2 bytes |
| Parity check | None/Even/Odd |

1) Refer to the following when connecting the communication line:

- Use a 2-pair STP (Shielded Twisted Pair) cable (use only pin 1: S+ and pin 8: S-, pin 1 and pin 8 have to be twisted type) and RJ45 STP plug. For connections between inverters or extension cables, use an RJ45 coupler (Y-type LAN coupler that the STP plug can be attached to). Use cables, plugs, and couplers that conform to the LAN standard: CAT5, CAT5e, and CAT6.
- Maintain a safe distance between the communication line and the power cable.

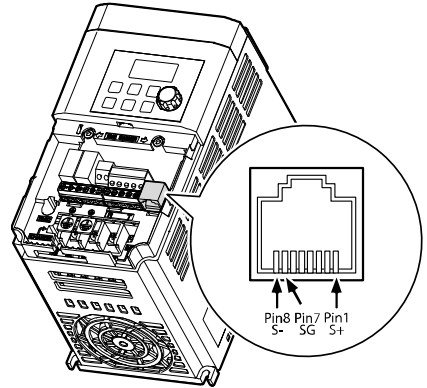

8.2 Communication System Configuration

In an RS-485 communication system, the PLC or computer is the master device and the inverter is the slave device. When using a computer as the master, the RS-232 converter must be integrated with the computer, so that it can communicate with the inverter through the RS-232/RS-485 converter. Specifications and performance of converters may vary depending on the manufacturer, but the basic functions are identical. Please refer to the converter manufacturer's user manual for details about features and specifications.

Connect the wires and configure the communication parameters on the inverter by referring to the following illustration of the communication system configuration.

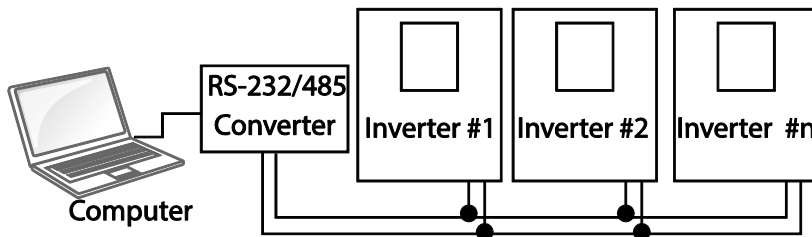

8.2.1 Communication Line Connection

Make sure that the inverter is turned off completely, and then connect the RS-485 communication line to the RJ45 connector (pin 1: S+, pin 8: S-, of the I/O board. The maximum number of inverters you can connect is 16. Use a shielded twisted pair cable for communication, and keep it a safe distance from the power cable during installation.

The maximum length of the communication line is 1,200 meters, but it is recommended to use no more than 700 meters of communication line to ensure stable communication. Please use a repeater to enhance the communication speed when using a communication line longer than 1,200 meters or when using a large number of devices. A repeater is effective when smooth communication is not available due to noise interference.

8.2.2 Setting Communication Parameters

Before proceeding with setting communication configurations, make sure that the communication lines are connected properly. Turn on the inverter and set the communication parameters.

| Group | Code | Name | Parameter Setting | | Setting Range | Unit |
|-------------------------------------|------|----------------------------------|-------------------|------------|---------------|------|
| CM (Communication) ¹⁾ | 01 | Inverter station ID | 1 | | 1–250 | - |
| | 02 | Communication protocol selection | 0 | ModBus RTU | 0, 1 | - |
| | 03 | Communication speed | 3 | 9,600 bps | 0–5 | - |
| | 04 | Parity/stop bit setting | 0 | D8/PN/S1 | 0–3 | - |
| | 05 | Communication time setting | 5 | | 2–100 | msec |

1) Available only for models equipped with advanced I/O.

Communication Parameters Setting Details

| Code | Description | | | | | | | | | | | | | | | | | | | | | | |
|------|--------------------------------------------------------------------------------------------------------------------------------------------------------------------------------------------------------------------------------------------------------------------------------------------------------------------------------------------------------------------------------------------------------------------------------------------------------------------------------------------------------------------------------------------------------------------------------------------------------------------------------------------------------------------------------------------------------------------------------------------------------------------------------------------------------------------------------|-------------------------------------------|--|---------|----------|---|------------|-------------------------------------------|---|------------|-------------------------------------------|---|----------|---------------------------------------|---|----------|--------------------------------------|---|--|------------|---|--|------------|
| CM01 | Set the inverter station ID between 1 and 250. Set the inverter station ID between 1 and 250. | | | | | | | | | | | | | | | | | | | | | | |
| CM02 | Select one of the two built-in protocols: Modbus-RTU or LS INV 485. <table border="1" style="width: 100%; border-collapse: collapse;"> <thead> <tr> <th style="width: 10%;"></th> <th style="width: 30%;">Setting</th> <th style="width: 60%;">Function</th> </tr> </thead> <tbody> <tr> <td style="text-align: center;">0</td> <td>Modbus-RTU</td> <td>Modbus-RTU compatible protocol</td> </tr> <tr> <td style="text-align: center;">1</td> <td>LS INV 485</td> <td>Dedicated protocol for the LS inverter</td> </tr> </tbody> </table> | | | Setting | Function | 0 | Modbus-RTU | Modbus-RTU compatible protocol | 1 | LS INV 485 | Dedicated protocol for the LS inverter | | | | | | | | | | | | |
| | Setting | Function | | | | | | | | | | | | | | | | | | | | | |
| 0 | Modbus-RTU | Modbus-RTU compatible protocol | | | | | | | | | | | | | | | | | | | | | |
| 1 | LS INV 485 | Dedicated protocol for the LS inverter | | | | | | | | | | | | | | | | | | | | | |
| CM03 | Set a communication setting speed up to 115,200 bps. <table border="1" style="width: 100%; border-collapse: collapse;"> <thead> <tr> <th style="width: 10%;"></th> <th style="width: 30%;">Setting</th> <th style="width: 60%;">Function</th> </tr> </thead> <tbody> <tr> <td style="text-align: center;">0</td> <td></td> <td>1,200 bps</td> </tr> <tr> <td style="text-align: center;">1</td> <td></td> <td>2,400 bps</td> </tr> <tr> <td style="text-align: center;">2</td> <td></td> <td>4,800 bps</td> </tr> <tr> <td style="text-align: center;">3</td> <td></td> <td>9,600 bps</td> </tr> <tr> <td style="text-align: center;">4</td> <td></td> <td>19,200 bps</td> </tr> <tr> <td style="text-align: center;">5</td> <td></td> <td>38,400 bps</td> </tr> </tbody> </table> | | | Setting | Function | 0 | | 1,200 bps | 1 | | 2,400 bps | 2 | | 4,800 bps | 3 | | 9,600 bps | 4 | | 19,200 bps | 5 | | 38,400 bps |
| | Setting | Function | | | | | | | | | | | | | | | | | | | | | |
| 0 | | 1,200 bps | | | | | | | | | | | | | | | | | | | | | |
| 1 | | 2,400 bps | | | | | | | | | | | | | | | | | | | | | |
| 2 | | 4,800 bps | | | | | | | | | | | | | | | | | | | | | |
| 3 | | 9,600 bps | | | | | | | | | | | | | | | | | | | | | |
| 4 | | 19,200 bps | | | | | | | | | | | | | | | | | | | | | |
| 5 | | 38,400 bps | | | | | | | | | | | | | | | | | | | | | |
| CM04 | Set a communication configuration. Set the data length, parity check method, and the number of stop bits. <table border="1" style="width: 100%; border-collapse: collapse;"> <thead> <tr> <th style="width: 10%;"></th> <th style="width: 20%;">Setting</th> <th style="width: 70%;">Function</th> </tr> </thead> <tbody> <tr> <td style="text-align: center;">0</td> <td>D8/PN/S1</td> <td>8-bit data / no parity check / 1 stop bit</td> </tr> <tr> <td style="text-align: center;">1</td> <td>D8/PN/S2</td> <td>8-bit data / no parity check / 2 stop bit</td> </tr> <tr> <td style="text-align: center;">2</td> <td>D8/PE/S1</td> <td>8-bit data / even parity / 1 stop bit</td> </tr> <tr> <td style="text-align: center;">3</td> <td>D8/PO/S1</td> <td>8-bit data / odd parity / 1 stop bit</td> </tr> </tbody> </table> | | | Setting | Function | 0 | D8/PN/S1 | 8-bit data / no parity check / 1 stop bit | 1 | D8/PN/S2 | 8-bit data / no parity check / 2 stop bit | 2 | D8/PE/S1 | 8-bit data / even parity / 1 stop bit | 3 | D8/PO/S1 | 8-bit data / odd parity / 1 stop bit | | | | | | |
| | Setting | Function | | | | | | | | | | | | | | | | | | | | | |
| 0 | D8/PN/S1 | 8-bit data / no parity check / 1 stop bit | | | | | | | | | | | | | | | | | | | | | |
| 1 | D8/PN/S2 | 8-bit data / no parity check / 2 stop bit | | | | | | | | | | | | | | | | | | | | | |
| 2 | D8/PE/S1 | 8-bit data / even parity / 1 stop bit | | | | | | | | | | | | | | | | | | | | | |
| 3 | D8/PO/S1 | 8-bit data / odd parity / 1 stop bit | | | | | | | | | | | | | | | | | | | | | |
| CM05 | Set the response time for the slave (inverter) to react to the request from the master. Response time is used in a system where the slave device response is too fast for the master device to process. Set this code to an appropriate value for smooth master-slave communication. <div style="text-align: center; margin-top: 20px;"> <p>The diagram illustrates the timing between a Master and a Slave. The Master sends a 'Request' pulse, and the Slave responds with an 'Answer' pulse. This sequence is repeated. The time interval between the start of the Master's request and the start of the Slave's answer is indicated by a double-headed arrow and labeled 'CM.5 Resp'. Ellipses (...) indicate that the communication continues.</p> </div> | | | | | | | | | | | | | | | | | | | | | | |

8.2.3 Setting Operation Command and Frequency

To select the built-in RS485 communication as the source of command, set the Frq code to 9 (Int485) on the keypad (basic keypad with 7-segment display). On an LCD keypad, set the DRV code to 3 (Int485). Then, set common area parameters for the operation command and frequency via communication.

| Group | Code | Name | Parameter Setting | | Setting Range | Unit |
|-----------|------|--------------------------|-------------------|-----------------------|---------------|------|
| Operation | drv | Command source | 3 | Int 485 ¹⁾ | 0–3 | - |
| | Frq | Frequency setting method | 9 | Int 485 ¹⁾ | 0–11 | - |

1) Available only for models equipped with advanced I/O.

8.2.4 Command Loss Protective Operation

Configure the command loss decision standards and protective operations run when a communication problem lasts for a specified period of time.

Command Loss Protective Operation Setting Details

| Code and Function | Description | | |
|---------------------------------------------------------------------------------|----------------------------------------------------------------------------------------------------------------|----------|------------------------------------------------------------------------------------------------------------------------|
| Pr12 Motion at speed command loss, Pr13 Time to determine speed command loss | Select the operation to run when a communication error has occurred and lasted exceeding the time set at Pr13. | | |
| | Pr12 Setting | | Function |
| | 0 | None | The speed command before the command loss immediately becomes the operation frequency without any protection function. |
| | 1 | Free-Run | The inverter blocks output. The motor performs in free-run condition. |
| | 2 | Dec | The motor decelerates and then stops. |

8.2.5 Parameter Group for Data Transmission

By defining a parameter group for data transmission, the communication addresses registered in the communication function group (CM) can be used in communication. Parameter group for data transmission may be defined to transmit multiple parameters at once, into the communication frame.

| Group | Code | Name | Parameter Setting | Setting Range | Unit |
|-------------------------------------|-------|------------------------------|-------------------|---------------|------|
| CM (Communication) ¹⁾ | 31–38 | Read address registration x | - | 0000–A4FF | Hex |
| | 51–58 | Write address registration x | - | 0000–A4FF | Hex |

1) Available only for models equipped with advanced I/O.

Currently Registered CM Group Parameter

| Address | Parameter | Assigned content by bit |
|-------------------|-----------------------------------------------------|-------------------------------------------------------------------------------|
| 0h0100– 0h0107 | Status Parameter- 1– Status Parameter-8 | Parameter communication code value registered at CM.31-38 (Read-only) |
| 0h0108– 0h010F | Control Parameter- 1– Control Parameter- 8 | Parameter communication code value registered at CM.51-58 (Read/Write access) |

8.3 Communication Protocol

The built-in RS-485 communication supports LS INV 485 and Modbus-RTU protocols.

8.3.1 LS INV 485 Protocol

The slave device (inverter) responds to read and write requests from the master device (PLC or PC).

Request

| ENQ | Station ID | CMD | Data | SUM | EOT |
|--------|------------|--------|---------|---------|--------|
| 1 byte | 2 bytes | 1 byte | n bytes | 2 bytes | 1 byte |

Normal Response

| ACK | Station ID | CMD | Data | SUM | EOT |
|--------|------------|--------|-------------|---------|--------|
| 1 byte | 2 bytes | 1 byte | n x 4 bytes | 2 bytes | 1 byte |

Error Response

| NAK | Station ID | CMD | Error code | SUM | EOT |
|--------|------------|--------|------------|---------|--------|
| 1 byte | 2 bytes | 1 byte | 2 bytes | 2 bytes | 1 byte |

- A request starts with ENQ and ends with EOT.
- A normal response starts with ACK and ends with EOT.
- An error response starts with NAK and ends with EOT.
- A station ID indicates the inverter number and is displayed as a two-byte ASCII-HEX string that uses characters 0-9 and A-F.
- CMD: Uses uppercase characters (returns an IF error if lowercase characters are encountered)—please refer to the following table.

| Character | ASCII-HEX | Command |
|-----------|-----------|------------------------------|
| 'R' | 52h | Read |
| 'W' | 57h | Write |
| 'X' | 58h | Request monitor registration |
| 'Y' | 59h | Perform monitor registration |

- Data: ASCII-HEX (for example, when the data value is 3000: 3000 → '0"B"B"8'h → 30h 42h 42h 38h)•Data: ASCII-HEX (for example, when the data value is 3000: 3000 → '0"B"B"8'h → 30h 42h 42h 38h)
- Error code: ASCII-HEX
- Transmission/reception buffer size: Transmission=39 bytes, Reception=44 bytes
- Monitor registration buffer: 8 Words
- SUM: Checks communication errors via sum.
SUM=a total of the lower 8 bits values for station ID, command and data (Station ID+CMD+Data) in ASCII-HEX.

For example, a command to read 1 address from address 3000:

SUM='0'+1+'R'+3+'0'+0+'0'+1' = 30h+31h+52h+33h+30h+30h+30h+31h = 1A7h
(the control value is not included: ENQ, ACK, NAK, etc.).

| ENQ | Station ID | CMD | Address | Number of Addresses | SUM | EOT |
|--------|------------|--------|---------|---------------------|---------|--------|
| 05h | '01' | 'R' | '3000' | '1' | 'A7' | 04h |
| 1 byte | 2 bytes | 1 byte | 4 bytes | 1 byte | 2 bytes | 1 byte |

Note

Broadcasting

Broadcasting sends commands to all inverters connected to the network simultaneously. When commands from Master are sent with station ID = 255, each inverter acts on the command regardless of the station ID. However no response is issued for commands transmitted by broadcasting.

8.3.1.1 Detailed Read Protocol

Read Request: Reads successive n words from address XXXX.

| ENQ | Station ID | CMD | Address | Number of Addresses | SUM | EOT |
|--------|------------|--------|---------|---------------------|---------|--------|
| 05h | '01'-'FA' | 'R' | 'XXXX' | '1'-'8' = n | 'XX' | 04h |
| 1 byte | 2 bytes | 1 byte | 4 bytes | 1 byte | 2 bytes | 1 byte |

Total bytes=12. Characters are displayed inside single quotation marks (').

Read Normal Response

| ACK | Station ID | CMD | Data | SUM | EOT |
|--------|------------|--------|-------------|---------|--------|
| 06h | '01'-'FA' | 'R' | 'XXXX' | 'XX' | 04h |
| 1 byte | 2 bytes | 1 byte | n x 4 bytes | 2 bytes | 1 byte |

Total bytes= (7 x n x 4): a maximum of 39

Read Error Response

| NAK | Station ID | CMD | Error code | SUM | EOT |
|--------|------------|--------|------------|---------|--------|
| 15h | '01'-'FA' | 'R' | *** | 'XX' | 04h |
| 1 byte | 2 bytes | 1 byte | 2 bytes | 2 bytes | 1 byte |

Total bytes=9

8.3.1.2 Detailed Write Protocol

Write Request

| ENQ | Station ID | CMD | Address | Number of Addresses | Data | SUM | EOT |
|--------|------------|--------|---------|---------------------|-------------|---------|--------|
| 05h | '01'-'FA' | 'W' | 'XXXX' | '1'-'8' = n | 'XXXX...' | 'XX' | 04h |
| 1 byte | 2 bytes | 1 byte | 4 bytes | 1 byte | n x 4 bytes | 2 bytes | 1 byte |

Total bytes= (12 x n x 4): a maximum of 44

Write Normal Response

| ACK | Station ID | CMD | Data | SUM | EOT |
|--------|------------|--------|-------------|---------|--------|
| 06h | '01'-'FA' | 'W' | 'XXXX...' | 'XX' | 04h |
| 1 byte | 2 bytes | 1 byte | n x 4 bytes | 2 bytes | 1 byte |

Total bytes= (7 x n x 4): a maximum of 39

Write Error Response

| NAK | Station ID | CMD | Error code | SUM | EOT |
|--------|------------|--------|------------|---------|--------|
| 15h | '01'-'FA' | 'W' | '**' | 'XX' | 04h |
| 1 byte | 2 bytes | 1 byte | 2 bytes | 2 bytes | 1 byte |

Total bytes=9

Note

Operation command and command frequency return the past data when answering the first write request, and return their own data when answering the second write request.

8.3.1.3 Monitor Registration Detailed Protocol

Monitor registration request is made to designate the type of data that requires continuous monitoring and periodic updating.

Monitor Registration Request: Registration requests for n addresses (where n refers to the number of addresses. The addresses do not have to be contiguous.)

| ENQ | Station ID | CMD | Number of Addresses | Address | SUM | EOT |
|--------|------------|--------|---------------------|-------------|---------|--------|
| 05h | '01'-'FA' | 'X' | '1'-'8'=n | 'XXXX...' | 'XX' | 04h |
| 1 byte | 2 bytes | 1 byte | 1 byte | n x 4 bytes | 2 bytes | 1 byte |

Total bytes= (8 x n x 4): a maximum of 40

Monitor Registration Normal Response

| ACK | Station ID | CMD | SUM | EOT |
|--------|------------|--------|---------|--------|
| 06h | '01'-'FA' | 'X' | 'XX' | 04h |
| 1 byte | 2 bytes | 1 byte | 2 bytes | 1 byte |

Total bytes=7

Monitor Registration Error Response

| NAK | Station ID | CMD | Error code | SUM | EOT |
|--------|------------|--------|------------|---------|--------|
| 15h | '01'-'FA' | 'X' | *** | 'XX' | 04h |
| 1 byte | 2 bytes | 1 byte | 2 bytes | 2 bytes | 1 byte |

Total bytes=9

Monitor Registration Perform Request: A data read request for a registered address, received from a monitor registration request

| ENQ | Station ID | CMD | SUM | EOT |
|--------|------------|--------|---------|--------|
| 05h | '01'-'FA' | 'Y' | 'XX' | 04h |
| 1 byte | 2 bytes | 1 byte | 2 bytes | 1 byte |

Total bytes=7

Monitor Registration Execution Normal Response

| ACK | Station ID | CMD | Data | SUM | EOT |
|--------|------------|--------|-------------|---------|--------|
| 06h | '01'-'FA' | 'Y' | 'XXXX...' | 'XX' | 04h |
| 1 byte | 2 bytes | 1 byte | n x 4 bytes | 2 bytes | 1 byte |

Total bytes= (7 x n x 4): a maximum of 39

Monitor Registration Execution Error Response

| NAK | Station ID | CMD | Error code | SUM | EOT |
|--------|------------|--------|------------|---------|--------|
| 15h | '01'-'FA' | 'Y' | *** | 'XX' | 04h |
| 1 byte | 2 bytes | 1 byte | 2 bytes | 2 bytes | 1 byte |

Total bytes=9

8.3.1.4 Error code

| Item | Abbreviation | Description |
|----------------------|--------------|-------------------------------------------------------------------------------------------------------------------------------------|
| ILLEGAL FUNCTION | IF | The requested function cannot be performed by a slave because the corresponding function does not exist. |
| ILLEGAL DATA ADDRESS | IA | The received parameter address is invalid at the slave. |
| ILLEGAL DATA VALUE | ID | The received parameter data is invalid at the slave. |
| WRITE MODE ERROR | WM | Tried writing (W) to a parameter that does not allow writing (read-only parameters, or when writing is prohibited during operation) |
| FRAME ERROR | FE | The frame size does not match. |

8.3.1.5 ASCII Code

| Character | Hex | Character | Hex | Character | Hex |
|-----------|-----|-----------|-----|-----------|-----|
| A | 41 | q | 71 | @ | 40 |
| B | 42 | r | 72 | [| 5B |
| C | 43 | s | 73 | \ | 5C |
| D | 44 | t | 74 |] | 5D |
| E | 45 | u | 75 | | 5E |
| F | 46 | v | 76 | | 5F |
| G | 47 | w | 77 | | 60 |
| H | 48 | x | 78 | { | 7B |
| I | 49 | y | 79 | | 7C |
| J | 4A | z | 7A | } | 7D |
| K | 4B | 0 | 30 | ~ | 7E |
| L | 4C | 1 | 31 | BEL | 07 |
| M | 4D | 2 | 32 | BS | 08 |
| N | 4E | 3 | 33 | CAN | 18 |
| O | 4F | 4 | 34 | CR | 0D |
| P | 50 | 5 | 35 | DC1 | 11 |
| Q | 51 | 6 | 36 | DC2 | 12 |
| R | 52 | 7 | 37 | DC3 | 13 |
| S | 53 | 8 | 38 | DC4 | 14 |
| T | 54 | 9 | 39 | DEL | 7F |
| U | 55 | space | 20 | DLE | 10 |
| V | 56 | ! | 21 | EM | 19 |
| W | 57 | " | 22 | ACK | 06 |
| X | 58 | # | 23 | ENQ | 05 |
| Y | 59 | \$ | 24 | EOT | 04 |
| Z | 5A | % | 25 | ESC | 1B |
| a | 61 | & | 26 | ETB | 17 |
| b | 62 | ' | 27 | ETX | 03 |
| c | 63 | (| 28 | FF | 0C |
| d | 64 |) | 29 | FS | 1C |
| e | 65 | * | 2A | GS | 1D |
| f | 66 | + | 2B | HT | 09 |
| g | 67 | , | 2C | LF | 0A |
| h | 68 | - | 2D | NAK | 15 |
| i | 69 | . | 2E | NUL | 00 |
| j | 6A | / | 2F | RS | 1E |
| k | 6B | : | 3A | S1 | 0F |
| l | 6C | ; | 3B | SO | 0E |
| m | 6D | < | 3C | SOH | 01 |
| n | 6E | = | 3D | STX | 02 |
| o | 6F | > | 3E | SUB | 1A |
| p | 70 | ? | 3F | SYN | 16 |
| | | | | US | 1F |
| | | | | VT | 0B |

8.3.2 Modbus-RTU Protocol

8.3.2.1 Function Code and Protocol (unit: byte)

In the following section, station ID is the value set at CM01 (Int485 St ID), and starting address is the communication address (starting address size is in bytes). For more information about communication addresses, refer to [8.4 Compatible Common Area Parameter](#) on page 186.

Function Code #03: Read Holding Register

| Query Field Name | Response Field Name |
|---------------------|---------------------|
| Station ID | Station ID |
| Function(0x03) | Function(0x03) |
| Starting Address Hi | Byte Count |
| Starting Address Lo | Data Hi |
| # of Points Hi | Data Lo |
| # of Points Lo | ... |
| CRC Lo | ... |
| CRC Hi | Data Hi |
| | Data Lo |
| | CRC Lo |
| | CRC Hi |

number of Points

Function Code #04: Read Input Register

| Query Field Name | Response Field Name |
|---------------------|---------------------|
| Station ID | Station ID |
| Function(0x04) | Function(0x04) |
| Starting Address Hi | Byte Count |
| Starting Address Lo | Data Hi |
| # of Points Hi | Data Lo |
| # of Points Lo | ... |
| CRC Lo | ... |
| CRC Hi | Data Hi |
| | Data Lo |
| | CRC Lo |
| | CRC Hi |

number of Points

Function Code #06: Preset Single Register

| Query Field Name | Response Field Name |
|---------------------|---------------------|
| Station ID | Station ID |
| Function(0x06) | Function(0x06) |
| Starting Address Hi | Register Address Hi |
| Register Address Lo | Register Address Lo |
| Preset Data Hi | Preset Data Hi |
| Preset Data Lo | Preset Data Lo |
| CRC Lo | CRC Lo |
| CRC Hi | CRC Hi |

Function Code #16 (hex 0h10): Preset Multiple Register

| Query Field Name | Response Field Name |
|---------------------|---------------------|
| Station ID | Station ID |
| Function(0x10) | Function(0x10) |
| Starting Address Hi | Starting Address Hi |
| Starting Address Lo | Starting Address Lo |
| # of Register Hi | # of Register Hi |
| # of Register Lo | # of Register Lo |
| Byte Count | CRC Lo |
| Data Hi | CRC Hi |
| Data Lo | |
| ... | |
| ... | |
| Data Hi | |
| Data Lo | |
| CRC Lo | |
| CRC Hi | |

} # number of Points

Exception Code

| Code |
|--------------------------|
| 01: ILLEGAL FUNCTION |
| 02: ILLEGAL DATA ADDRESS |
| 03: ILLEGAL DATA VALUE |
| 06: SLAVE DEVICE BUSY |

Response

| Field Name |
|------------------------|
| Station ID |
| Function ¹⁾ |
| Exception Code |
| CRC Lo |
| CRC Hi |

1) The function value uses the top level bit for all query values.

Example of Modbus-RTU Communication in Use

When the Acc time (Communication address 0x1103) is changed to 5.0 sec and the Dec time (Communication address 0x1104) is changed to 10.0 sec.

Frame Transmission from Master to Slave (Request)

| Item | Station ID | Function | Starting Address | # of Register | Byte Count | Data 1 | Data 2 | CRC |
|-------------|-------------------|--------------------------|---------------------------------|---------------|------------|----------------------|------------------------|--------|
| Hex | 0x01 | 0x10 | 0x1102 | 0x0002 | 0x04 | 0x0032 | 0x0064 | 0x1202 |
| Description | CM 1 Int485 St ID | Preset Multiple Register | Starting Address - 1 (0x1103-1) | - | - | 50 (ACC time 5.0sec) | 100 (DEC time 10.0sec) | - |

Frame Transmission from Slave to Master (Response)

| Item | Station ID | Function | Starting Address | # of Register | CRC |
|-------------|-------------------|--------------------------|--------------------------------|---------------|--------|
| Hex | 0x01 | 0x10 | 0x1102 | 0x0002 | 0xE534 |
| Description | CM 1 Int485 St ID | Preset Multiple Register | Starting Address -1 (0x1103-1) | - | - |

8.4 Compatible Common Area Parameter

The following are common area parameters compatible with iS5, iP5A, iV5, iG5A, S100, and C100.

| Address | Parameter | Scale | Unit | R/W | Assigned Content by Bit |
|---------|------------------------------|-------|------|-----|---------------------------------------------------------------------------------------------------------------------------------------------------------------------------------------------------------------------------------------------------------------------------------------------------------------------------------------------------------------------------------------------------------------------------------------------------|
| 0x0000 | Inverter model | | | R | E: LSLV-M100 |
| 0x0001 | Inverter capacity | | | R | 0000: 0.1kW-1 0001: 0.2kW-1 0002: 0.4kW-1 |
| | | | | | 0003: 0.8kW-1 0004: 1.5kW-1 0005: 2.2kW-1 |
| | | | | | 000A: 1.5kW-2 000B: 2.2kW-2 000C: 3.7kW-2 |
| | | | | | 000F: 0.4kW-4 0010: 0.8kW-4 0011: 1.5kW-4 |
| | | | | | 0012: 2.2kW-4 0013: 3.7kW-4 |
| 0x0002 | Inverter input voltage | | | R | 0: 220V-1 phase, 1: 220V-3 phase, 2: 440V-3 phase |
| 0x0003 | Version | | | R | Example 0x0010: Version 1.01 |
| 0x0004 | Parameter setting | | | R/W | 0 : Prohibit communication settings, 1 : Allow communication settings |
| 0x0005 | Command Frequency | 0.01 | Hz | R/W | Start frequency - Maximum frequency |
| 0x0006 | Operation command (Advanced) | | | R | B15, B14, B13: Reserved |
| | | | | | B12, B11, B10, B9, B8: Frequency command information 0: Keypad-1, Keypad-2 1: Reserved 2: Multi-step speed 1 3: Multi-step speed 2 4: Multi-step speed 3 5: Multi-step speed 4 6: Multi-step speed 5 7: Multi-step speed 6 8: Multi-step speed 7 9: Up 10: Down 11: Up/down zero 12: V0 13: V1 14: I2(I) 15: I2(V) 16: V0+I2(I) 17: V0+I2(V) 18: V0+I2(V) 19: Communication operation |
| | | | | | B7, B6 : Operation command information 0: Terminal block 1: Keypad 3: Communication |
| | | | | | R/W B5 Reserved B4 Emergency stop B3 Fault reset B2 Reverse operation B1 Forward operation B0 Stop |
| 0x0007 | Acceleration time | 0.1 | sec | R/W | Refer to the table of functions |
| 0x0008 | Deceleration time | 0.1 | sec | R/W | Refer to the table of functions |
| 0x0009 | Current | 0.1 | A | R | Refer to the table of functions |

| Address | Parameter | Scale | Unit | R/W | Assigned Content by Bit | | | | | |
|---------|--------------------------------|-------|---------|-----|------------------------------------------------------------|-----------------|-----|--------------------------------|-----|-------|
| 0x000A | Output frequency | 0.01 | Hz | R | Refer to the table of functions | | | | | |
| 0x000B | Output voltage | 1 | V | R | Refer to the table of functions | | | | | |
| 0x000C | DC Link voltage | 1 | V | R | Refer to the table of functions | | | | | |
| 0x000D | Output power | 0.1 | kW | R | Refer to the table of functions | | | | | |
| 0x000E | Operation status | | | R | B15 | Reserved | B14 | Reserved | | |
| | | | | | B13 | Reserved | B12 | Reverse command | | |
| | | | | | B11 | Forward command | B10 | Brake release signal | | |
| | | | | | B9 | Reserved | B8 | Drive stopping | | |
| | | | | | B7 | DC Braking | B6 | Speed reached | | |
| | | | | | B5 | Decelerating | B4 | Accelerating | | |
| | | | | | B3 | Fault Trip | B2 | Operating in reverse direction | | |
| B1 | Operating in forward direction | B0 | Stopped | | | | | | | |
| 0x000F | Fault trip information-A | | | R | B15 | LVT | B14 | IOLT | B13 | POT |
| | | | | | B12 | FAN | B11 | EEP | B10 | EXT-B |
| | | | | | B9 | Reserved | B8 | OLT | B7 | ETH |
| | | | | | B6 | OHT | B5 | GFT | B4 | COL |
| | | | | | B3 | EST | B2 | EXT-A | B1 | OVT |
| | | | | | B0 | Reserved | | | | |
| 0x0010 | Input terminal information | | | R | B15-B5: Reserved | | | | | |
| | | | | | B4 | P5 | B3 | P4 | B2 | P3 |
| | | | | | B1 | P2 | B0 | P1 | | |
| 0x0011 | Output terminal information | | | R | B4 | 3ABC | | | | |
| | | | | | Others | Reserved | | | | |
| 0x0012 | V1 | | | R | The value corresponds to the 0-10 V input (0x0000-0x03FF) | | | | | |
| 0x0013 | V0 | | | R | 0-5V KPD Volume (0x0000-0x03FF) | | | | | |
| 0x0014 | I | | | R | The value corresponds to the 0-20 mA input (0x0000-0x03FF) | | | | | |

| Address | Parameter | Scale | Unit | R/W | Assigned Content by Bit |
|---------|--------------|-------|------|-----|---------------------------------|
| 0x0015 | RPM | | | R | Refer to the table of functions |
| 0x001A | Unit display | | | R | Not Used |

| Address | Parameter | Scale | Unit | R/W | Assigned Content by Bit | | | | | |
|---------------|----------------------------|-------|------|-----|----------------------------------------------------------------------------------------------------------------------------------------------|-----|----|----------|----|----------|
| 0x001B | Number of poles | | | R | Not Used | | | | | |
| 0x001C | Custom Version | | | R | Not Used | | | | | |
| 0x001D | Fault trip information -B | | | R | B9 | ROT | B7 | Reserved | B6 | Reserved |
| | | | | | B5 | NBR | B4 | OCT | B3 | REEP |
| | | | | | B2 | NTC | B1 | Reserved | B0 | COM |
| 0x001E | PID Feedback | | | R/W | When Feedback is set to communication in PID operation, the amount of feedback is written and read in 0.1% increments. | | | | | |
| 0x0100-0x0107 | Read address registration | | | R | 0h0100 : CM-31 0h0101 : CM-32 0h0102 : CM-33 0h0103 : CM-34 0h0104 : CM-35 0h0105 : CM-36 0h0106 : CM-37 0h0107 : CM-38 | | | | | |
| 0x0108-0x010F | Write address registration | | | W | 0h0108 : CM-51 0h0109 : CM-52 0h010A : CM-53 0h010B : CM-54 0h010C : CM-55 0h010D : CM-56 0h010E : CM-57 0h010F : CM-58 | | | | | |

Note

- Data cannot be saved when editing data via the common area parameter.
 - The data change is reflected temporarily, but the value will return to the previously set value when resetting or turning off and on the inverter.
 - When editing data via each group parameter other than the common area parameter, the data change will be maintained even after resetting or turning off and on the inverter.
- The software version in the common area is displayed in hexadecimal numbers, and the software version in the parameter area is displayed in decimal numbers.
- The 0x001E PID Feedback parameter in the common area can be written and read in 0.1% increments regardless of the AP2 PID unit setting parameter, and the amount of feedback that can be reflected or read is as follows:
 - When the maximum frequency is 60.00 Hz and writing 0x0032 (5.0%) to 0x001E:
 $60.00\text{Hz} \times 5.0\% = 3.00\text{Hz}$

9 Table of Functions

9.1 Operation Group

| Display | Comm. Address | Name | Setting Range | Initial Value | Property* | Page |
|---------|---------------|--------------------------|--------------------------------------|---------------|-----------|----------------------------------------------------------------------------------------------------------------------------------------------------------------------------------------------------------------------------------------------------------------------|
| 0.00 | 0h1F00 | Command frequency | 0.00–Maximum frequency [Hz] | 0.00 | ○ | p.67 , p.78 |
| ACC | 0h1F01 | Acceleration time | 0.0–6000.0 [s] ¹⁾ | 5.0 | ○ | p.65 , p.86 , p.95 |
| dEC | 0h1F02 | Deceleration time | | 10.0 | ○ | |
| drv | 0h1F03 | Command source | 0 Keypad | 1 | X | p.52 , p.64 , p.80 , p.132 , p.175 |
| | | | 1 Fx/Rx-1 | | | |
| | | | 2 Fx/Rx-2 | | | |
| | | | 3 RS-485 communication ²⁾ | | | |
| Frq | 0h1F04 | Frequency Setting method | 0 Keypad 1 | 0 | X | p.48 , p.52 , p.67 , p.75 , p.110 , p.112 , p.116 , p.117 , p.132 , p.175 |
| | | | 1 Keypad 2 | | | |
| | | | 2 V0: 0–5 [V], Built-in Volume | | | |
| | | | 3 V1: 0–10 [V] | | | |
| | | | 4 I2(I): 0–20 [mA] ²⁾ | | | |
| | | | 5 I2(V): 0–10 [V] ²⁾ | | | |
| | | | 6 V0 + I2 (I) ²⁾ | | | |
| | | | 7 V0 + I2 (V) ²⁾ | | | |
| | | | 8 V0 + V1 | | | |
| | | | 9 RS-485 communication ²⁾ | | | |
| | | | 10 Up-down operation | | | |
| | | | 11 V1 + I2 (V) ²⁾ | | | |

1) The setting range varies depending on the set value of the bA 8 code.

2) Available only for models equipped with advanced I/O.

* Settings can be changed during the inverter operation.

Table of Functions

| Display | Comm. Address | Name | Setting Range | | Initial Value | Property* | Page |
|---------------------------------------|---------------|------------------------|-------------------|----------------------------------------|---------------|-----------|-------------------------------------------------|
| MkW | 0h1F05 | Motor selection | 0.1 | 0.1kW | - | X | p.119 |
| | | | 0.2 | 0.2 kW | | | |
| | | | 0.4 | 0.4 kW | | | |
| | | | 0.75 | 0.75 kW | | | |
| | | | 1.1 | 1.1 kW | | | |
| | | | 1.5 | 1.5 kW | | | |
| 2.2 | 2.2 kW | | | | | | |
| MrC ³⁾ | 0h1F06 | Rated motor current | 0.1–150.0 [A] | | - | X | p.119 |
| MbF | 0h1F07 | Base frequency | 30.00–400.00 [Hz] | | 60.00 | X | p.65 , p.95 |
| FrM | 0h1F08 | Maximum frequency | 40.00–400.00 [Hz] | | 60.00 | X | p.65 , p.102 |
| IOv | 0h1F09 | Output voltage setting | 0, 170~264 [V] | | 0 | X | p.65 , p.97 |
| Ftb | 0h1F0A | Forward boost | 0.0–20.0 [%] | | 4.0 | X | p.65 , p.98 |
| rtb | 0h1F0B | Reverse boost | 0.0–20.0 [%] | | 4.0 | X | |
| CUr | 0h1F0C | Output current | - | | - | - | p.58 , p.151 |
| rPM | 0h1F0D | Motor RPM | - | | - | - | p.151 |
| dCL | 0h1F0E | Inverter DC voltage | - | | - | - | p.154 |
| vOL, POr, tOr, v1M, I2M ⁴⁾ | - | User select signal | vOL | Output voltage | vOL | - | p.151 |
| | | | POr | Output power | | | |
| | | | tOr | Output torque | | | |
| | | | v1M | Analog V1 terminal input | | | |
| | | | I2M | Analog I2 terminal input | | | |
| nOn | 0h1F10 | Current fault | - | | - | - | p.156 |
| OGr | 0h1F11 | Open hidden groups | 0 | Hide groups except for operation group | | | p.43 |
| | | | 1 | Enable all groups | | | |

3) The initial value varies depending on the motor capacity setting (MkW) and the value is set based on the 220/440 HIGEN motor when shipping.

4) Display information can be selected at dr81 (Monitor item setting).

* Settings can be changed during the inverter operation.

9.2 Drive Group (PAR → dr)

| Display | Comm. Address | Name | Setting Range | | Initial Value | Property* | Page |
|------------------|---------------|------------------------------------------|-----------------------------|-----------------------------------------------------|---------------|-----------|--------------------------------------------------------------------------|
| 00 | x | Jump Code | 0–81 | | 9 | O | p.46 |
| 09 | 0h1109 | Control mode | 0 | V/F schedule control | 1 | X | p. 95 p.119. p.148 |
| | | | 1 | Slip compensation control | | | |
| | | | 2 | Simple sensorless control | | | |
| 11 | 0h110B | Jog frequency | 0.00–Maximum frequency [Hz] | | 10.00 | O | p.110 |
| 15 | 0h110F | Torque boost | 0 | Manual torque boost | 0 | X | p.65. p.98. p.100 |
| | | | 1 | Automatic torque boost | | | |
| 19 | 0h1113 | Starting frequency | 0.10–10.00 [Hz] | | 0.50 | X | p.65. p.95. p.102 |
| 20 ¹⁾ | 0h1114 | Select rotation direction | F | Forward run | F | O | p.80 |
| | | | r | Reverse run | | | |
| 26 ²⁾ | 0h111A | Automatic torque boost filter gain | 1–1000 | | 2 | O | p.100 |
| 27 ²⁾ | 0h111B | Automatic torque boost motoring gain | 0.0–300.0 [%] | | 120.0 | O | |
| 28 ²⁾ | 0h111C | Automatic torque boost regeneration gain | 0.0–300.0 [%] | | 120.0 | O | |
| 81 | 0h1151 | Select Monitor code | 0 | Output voltage (vOL) [V] | 0 | O | p.151 |
| | | | 1 | Output power (POr) [kW] | | | |
| | | | 2 | Torque (tOr) [kgf · m] | | | |
| | | | 3 | Analog V1 terminal input (v1M) [V] | | | |
| | | | 4 | Analog I2 terminal input (I2M) [mA/V] ³⁾ | | | |

1) The rotation direction command by the dr20 setting is applied only when drv(Command source) is set to 0. You can still display and set the dr20 setting when drv(Command source) is set to other than 0.

2) Enable only when dr15 (Torque boost) is set to 1.

Table of Functions

3) Available only for models equipped with advanced I/O. The current and the voltage are displayed up to 20 mA and 10 V depending on the SW2 operation.

* Settings can be changed during the inverter operation.

| Display | Comm. Address | Name | Setting Range | | Initial Value | Property* | Page |
|------------------|---------------|------------------|---------------|-------------|---------------|-----------|--------------|
| 85 ⁴⁾ | x | Read Parameters | 0 | No | 0 | X | <u>p.246</u> |
| | | | 1 | Yes | | | |
| 86 ⁴⁾ | x | Write Parameters | 0 | No | 0 | X | <u>p.246</u> |
| | | | 1 | Yes | | | |
| 91 ⁵⁾ | 0h115B | Smart Copier | 0 | None | 0 | X | - |
| | | | 1 | Reserved | | | |
| | | | 2 | Reserved | | | |
| | | | 3 | SmartUpLoad | | | |

4) Displayed only when the remote keypad connect to the inverter.

5) Refer to Smart Copier User's Manual separately.

* Settings can be changed during the inverter operation.

9.3 Basic Function group (PAR→bA)

| Display | Comm. Address | Name | Setting Range | Initial Value | Property* | Page | |
|------------------|---------------|--------------------|---------------|------------------------------------|-----------|-------------|-----------------------------|
| 00 | x | Jump Code | 0–83 | 19 | O | <u>p.46</u> | |
| 04 ¹⁾ | 0h1204 | Command source 2 | 0 | Keypad | 1 | X | <u>p.46</u> <u>p.132</u> |
| | | | 1 | Fx/Rx-1 | | | |
| | | | 2 | Fx/Rx-2 | | | |
| | | | 3 | RS-485 communication ²⁾ | | | |
| 05 ¹⁾ | 0h1205 | Frequency source 2 | 0 | Keypad 1 | 0 | X | <u>p.46</u> <u>p.132</u> |
| | | | 1 | Keypad 2 | | | |
| | | | 2 | V0: 0–5 [V] | | | |
| | | | 3 | V1: 0–10 [V] | | | |
| | | | 4 | I2(I): 0–20 [mA] ²⁾ | | | |
| | | | 5 | I2(V): 0–10 [V] ²⁾ | | | |
| | | | 6 | Volume + I2 (I) ²⁾ | | | |
| | | | 7 | Volume + I2 (V) ²⁾ | | | |
| | | | 8 | Volume + V1 | | | |
| | | | 9 | RS-485 communication ²⁾ | | | |
| | | | 10 | Up-down operation | | | |
| 07 | 0h1207 | V/F pattern | 0 | Linear | 0 | X | <u>p.65</u> <u>p.95</u> |
| | | | 1 | Square reduction | | | |
| | | | 2 | 4.13.3 User V/F | | | |

1) Displayed only when one of the In65–69 (Multi-function input terminal function setting) is set to 22.

2) Available only for models equipped with advanced I/O.

* Settings can be changed during the inverter operation.

Table of Functions

| Display | Comm. Address | Name | Setting Range | Initial Value | Property* | Page | |
|------------------|---------------|------------------------------|-----------------|----------------------------------|-----------|---------------------|---------------------|
| 08 | 0h1208 | Unit of acc/dec time setting | bA08 setting | Acc/dec time setting range | 1 | O | <u>p.86</u> |
| | | | 0 (0.01 sec) | 0.01 .600–20.00 sec | | | |
| | | | 1 (0.1 sec) | 0.1–6000.0 sec | | | |
| | | | 2 (1 sec) | 1–60000 sec | | | |
| 09 | 0h1209 | Acc/dec frequency reference | 0 | Maximum frequency (FrM) | 0 | X | <u>p.65, p.86</u> |
| | | | 1 | Delta frequency | | | |
| 11 | 0h120B | Number of motor poles | 2–12 [pole] | 4 | X | <u>p.119, p.151</u> | |
| 12 ³⁾ | 0h120C | Rated motor slip current | 0.00–10.00 [Hz] | - | X | <u>p.119</u> | |
| 14 ³⁾ | 0h120E | Motor no-load current | 0.1–100.0 [A] | - | X | | |
| 15 ³⁾ | 0h120F | Motor efficiency | 50–100[%] | - | X | | |
| 16 | 0h1210 | Load inertia rate | 0 | Less than 10 times motor inertia | 0 | X | <u>p.107, p.119</u> |
| | | | 1 | 10 times motor inertia | | | |
| | | | 2 | More than 10 times motor inertia | | | |
| 19 | 0h1213 | Input voltage adjustment | 170–240 [V] | 220 | O | <u>p.135</u> | |
| 25 | 0h1219 | Slip gain | 0.0–150.0 [%] | 100.0 | O | - | |

3) The initial value varies depending on the motor capacity setting (MkW) and the value is set based on the 220/440 HIGEN motor when shipping.

* Settings can be changed during the inverter operation.

| Display | Comm. Address | Name | Setting Range | Initial Value | Property* | Page |
|------------------|---------------|------------------------|-----------------------------|---------------|-----------|---------------------------------------------|
| 41 ⁴⁾ | 0h1229 | User V/F frequency 1 | 0.00–Maximum frequency [Hz] | 15.00 | X | <u>p.65,</u> <u>p.95</u> |
| 42 ⁴⁾ | 0h122A | User V/F voltage 1 | 0–100 [%] | 25 | X | |
| 43 ⁴⁾ | 0h122B | User V/F frequency 2 | 0.00–Maximum frequency [Hz] | 30.00 | X | |
| 44 ⁴⁾ | 0h122C | User V/F voltage 2 | 0–100 [%] | 50 | X | |
| 45 ⁴⁾ | 0h122D | User V/F frequency 3 | 0.00–Maximum frequency [Hz] | 45.00 | X | |
| 46 ⁴⁾ | 0h122E | User V/F voltage 3 | 0–100 [%] | 75 | X | |
| 47 ⁴⁾ | 0h122F | User V/F frequency 4 | 0.00–Maximum frequency [Hz] | 60.00 | X | |
| 48 ⁴⁾ | 0h1230 | User V/F voltage 4 | 0–100 [%] | 100 | X | |
| 50 | 0h1232 | Multi-step frequency 1 | 0.00–Maximum frequency [Hz] | 10.00 | O | <u>p.65,</u> <u>p.78,</u> <u>p.88</u> |
| 51 | 0h1233 | Multi-step frequency 2 | | 20.00 | O | |
| 52 | 0h1234 | Multi-step frequency 3 | | 30.00 | O | |
| 53 | 0h1235 | Multi-step frequency 4 | | 30.00 | O | |
| 54 | 0h1236 | Multi-step frequency 5 | | 25.00 | O | |
| 55 | 0h1237 | Multi-step frequency 6 | | 20.00 | O | |
| 56 | 0h1238 | Multi-step frequency 7 | | 15.00 | O | |

4) Displayed only when bA07 (V/F pattern) is set to 2 (User V/F).

* Settings can be changed during the inverter operation.

Table of Functions

| Display | Comm. Address | Name | Setting Range | Initial Value | Property* | Page |
|---------|---------------|--------------------------------|-------------------------------|---------------|-----------|----------------------------|
| 70 | 0h1246 | Multi-step acceleration time 1 | 0.00–6000.0 [s] ⁵⁾ | 2.0 | O | <u>p.65</u> <u>p.88</u> |
| 71 | 0h1247 | Multi-step deceleration time 1 | | 2.0 | O | |
| 72 | 0h1248 | Multi-step acceleration time 2 | | 3.0 | O | |
| 73 | 0h1249 | Multi-step deceleration time 2 | | 3.0 | O | |
| 74 | 0h124A | Multi-step acceleration time 3 | | 4.0 | O | |
| 75 | 0h124B | Multi-step deceleration time 3 | | 4.0 | O | |
| 76 | 0h124C | Multi-step acceleration time 4 | | 5.0 | O | |
| 77 | 0h124D | Multi-step deceleration time 4 | | 5.0 | O | |
| 78 | 0h124E | Multi-step acceleration time 5 | | 4.0 | O | |
| 79 | 0h124F | Multi-step deceleration time 5 | | 4.0 | O | |
| 80 | 0h1250 | Multi-step acceleration time 6 | | 3.0 | O | |
| 81 | 0h1251 | Multi-step deceleration time 6 | | 3.0 | O | |
| 82 | 0h1252 | Multi-step acceleration time 7 | | 2.0 | O | |
| 83 | 0h1253 | Multi-step deceleration time 7 | | 2.0 | O | |

5) The setting range varies depending on the set value of the bA08 code.

* Settings can be changed during the inverter operation.

9.4 Expanded Function group (PAR→Ad)

| Display | Comm. Address | Name | Setting Range | Initial Value | Property* | Page |
|------------------|---------------|----------------------------------------|------------------------------------------|-------------------------------|-----------|--------------------|
| 00 | x | Jump Code | 0–79 | 24 | O | <u>p.43</u> |
| 01 | 0h1301 | Acceleration pattern | 0 | Linear pattern | 0 | X |
| | | | 1 | S pattern | | |
| 02 | 0h1302 | Deceleration pattern | 0 | Linear | 0 | X |
| | | | 1 | S-curve | | |
| 03 | 0h1303 | S-curve start point gradient | 1–100 [%] | 40 | X | <u>p.91</u> |
| 04 | 0h1304 | S-curve end point gradient | 1–100 [%] | 40 | X | |
| 08 | 0h1308 | Stop mode selection | 0 | Deceleration stop | 0 | X |
| | | | 1 | DC braking stop | | |
| | | | 2 | Free run stop | | |
| 09 | 0h1309 | Forward and reverse run prevention | 0 | Allow forward and reverse run | 0 | X |
| | | | 1 | Prevent forward run | | |
| | | | 2 | Prevent reverse run | | |
| 10 | 0h130A | Starting with power on selection | 0 | No | 0 | O |
| | | | 1 | Yes | | |
| 12 | 0h130C | DC braking time at startup | 0.0–60.0 [s] | 0.0 | X | <u>p.107</u> |
| 13 | 0h130D | DC braking rate at startup | 0–200 [%] | 50 | X | |
| 14 ¹⁾ | 0h130E | Output blocking time before DC braking | 0.00–60.00 [s] | 0.00 | X | <u>p.65, p.107</u> |
| 15 ¹⁾ | 0h130F | DC braking time | 0.0–60.0 [s] | 1.0 | X | |
| 16 ¹⁾ | 0h1310 | DC braking rate | 0–200 [%] | 50 | X | |
| 17 ¹⁾ | 0h1311 | DC braking frequency | Start frequency–60.00 [Hz] | 5.00 | X | |
| 20 | 0h1314 | Frequency | Start frequency - Maximum frequency [Hz] | 5.00 | X | |
| 21 | 0h1315 | Dwell time | 0.0–10.0 [초] | 0.0 | X | <u>p.65, p.117</u> |

1) Displayed only when Ad08 is set to 1 (DC braking stop).

* Settings can be changed during the inverter operation.

Table of Functions

| Display | Comm. Address | Name | Setting Range | | Initial Value | Property* | Page |
|------------------|---------------|---------------------------------|-------------------------------------------------------|-----|---------------|-----------|------------------------------|
| 24 | 0h1318 | Frequency lower and upper limit | 0 | No | 0 | X | <u>p.102</u> |
| | | | 1 | Yes | | | |
| 25 ²⁾ | 0h1319 | Frequency lower limit | Starting frequency–frequency upper limit [Hz] | | 0.50 | X | <u>p.65,</u> <u>p.102</u> |
| 26 ²⁾ | 0h131A | Frequency upper limit | 0.00–Maximum frequency [Hz] | | 60.00 | X | |
| 27 | 0h131B | Frequency jump | 0 | No | 0 | X | <u>p.104</u> |
| | | | 1 | Yes | | | |
| 28 ³⁾ | 0h131C | Frequency jump lower limit 1 | Starting frequency–frequency jump upper limit [Hz] | | 10.00 | X | |
| 29 ³⁾ | 0h131D | Frequency jump upper limit 1 | Frequency jump lower limit 1–maximum frequency [Hz] | | 15.00 | | |
| 30 ³⁾ | 0h131E | Frequency jump lower limit 2 | Starting frequency–frequency jump upper limit 2 [Hz] | | 20.00 | | |
| 31 ³⁾ | 0h131F | Frequency jump upper limit 2 | Frequency jump lower limit 2–maximum frequency [Hz] | | 25.00 | | |
| 32 ³⁾ | 0h1320 | Frequency jump lower limit 3 | Starting frequency–frequency jump upper limit 3– [Hz] | | 30.00 | | |
| 33 ³⁾ | 0h1321 | Frequency jump upper limit 3 | Frequency jump lower limit 3–maximum frequency [Hz] | | 35.00 | | |

2) Displayed only when Ad24 (Frequency lower and upper limit) is set to 1.

3) Displayed only when Ad27 (Frequency jump) is set to 1.

* Settings can be changed during the inverter operation.

| Display | Comm. Address | Name | Setting Range | Initial Value | Property* | Page | |
|------------------|---------------|--------------------------------------------|-----------------------------|---------------------------------------------------------|--------------|---------------------|---|
| 41 ⁴⁾ | 0h1329 | Brake open current | 0.0–180.0 [%] | 50.0 | O | <u>p.140, p.220</u> | |
| 42 ⁴⁾ | 0h132A | Brake open delay time | 0.00–10.00 [s] | 1.00 | X | <u>p.140</u> | |
| 44 ⁴⁾ | 0h132C | Brake open forward frequency | 0.00–Maximum frequency [Hz] | 1.00 | X | | |
| 45 ⁴⁾ | 0h132D | Brake open reverse frequency | 0.00–Maximum frequency [Hz] | 1.00 | X | | |
| 46 ⁴⁾ | 0h132E | Brake close delay time | 0.00–10.00 [s] | 1.00 | X | | |
| 47 ⁴⁾ | 0h132F | Brake close frequency | 0.00–Maximum frequency [Hz] | 2.00 | X | | |
| 51 | 0h1333 | Energy saving operation | 0–30 [%] | 0 | O | <u>p.126</u> | |
| 63 | 0h133F | Motor RPM display gain | 1–1000 [%] | 100 | O | <u>p.151</u> | |
| 64 ⁵⁾ | 0h1340 | Up-down operation frequency save | 0.00–Maximum frequency [Hz] | 0.00 | O | <u>p.76, p.112</u> | |
| 65 | 0h1341 | Up-down operation frequency save selection | 0 | No | 0 | | X |
| | | | 1 | Yes | | | |
| 66 | 0h1342 | Up-down operation mode selection | 0 | Maximum/minimum frequency reference | 0 | X | |
| | | | 1 | Increase or decrease based on the step frequency (Ad67) | | | |
| | | | 2 | Mixed function of 0 and 1 | | | |
| 67 | 0h1343 | Up-down operation step frequency | 0.00–Maximum frequency [Hz] | 0.00 | X | <u>p.76, p.112</u> | |
| 68 ⁶⁾ | 0h1344 | Cooling Fan Control | 0 | During Run | 0:During Run | | O |
| | | | 1 | Always ON | | | |
| | | | 2 | Temp Control | | | |
| 79 | 0h134F | DB operation voltage | 300–400 [V] | 390 | X | - | |

4) Displayed only when OU31 (Multi-function relay setting) or OU32 (Multi-function output 2 function

setting) is set to 19 (Brake signal setting).

5) Displayed only when Ad65 (Up-down operation frequency save selection) is set to 1.

* Settings can be changed during the inverter operation.

6) Cooling Fan Control function(Ad.68), this function is applied to the products produced after December, 2022.

9.5 Control Function group (PAR→Cn)

| Display | Comm Address | Name | Setting Range | Initial Value | Property* | Page | |
|---------|--------------|-------------------------------------------------------|----------------|----------------------------------------------------------------|-----------|--------------------------------------------------|----------------------------------------------------------------------------|
| 00 | x | Jump Code | 0–74 | 4 | O | p.43 | |
| 04 | 0h1404 | Carrier frequency settings (operation noise settings) | 1.0–15.0 [kHz] | 3.0 | O | p.130 , p.222 | |
| 71 | 0h1447 | Speed search selection | BITS | 0000–1111 | 0000 | X | p.40 , p.127 , p.220 |
| | | | --1 | Speed search on general acceleration | | | |
| | | | --1- | Speed search on operation after fault trip | | | |
| | | | -1-- | Speed search on restart after instantaneous power interruption | | | |
| | | | 1--- | Speed search when power is on (Ad10) | | | |
| 72 | 0h1448 | Speed search current level | 80–200 [%] | 100 | O | p.127 | |
| 73 | 0h1449 | Speed search P gain | 0–9999 | 500 | O | | |
| 74 | 0h144A | Speed search I gain | 0–9999 | 1000 | O | | |

* Settings can be changed during the inverter operation.

9.6 Input Terminal Block Function group (PAR→In)

| Display | Comm. Address | Name | Setting Range | Initial Value | Property* | Page |
|---------|---------------|-----------------------------------------------------|------------------------------------|---------------|-----------|---------------------------------------------------------------------------|
| 00 | x | Jump Code | 0–90 | 65 | ○ | p.43 |
| 07 | 0h1507 | Time constant of V1 input filter | 0–9999 | 10 | ○ | p.62 , p.68 , p.135 |
| 08 | 0h1508 | V1 Minimum input voltage | 0.00–V1 Maximum input voltage [V] | 0.00 | ○ | p.62 , p.68 , p.135 |
| 09 | 0h1509 | Frequency corresponding to V1 minimum input voltage | 0.00–Maximum frequency [Hz] | 0.00 | ○ | p.62 , p.68 , p.135 |
| 10 | 0h150A | V1 Maximum input voltage | V1 Minimum input voltage–10.00 [V] | 10.00 | ○ | |
| 11 | 0h150B | Frequency corresponding to V1 maximum input voltage | 0.00–Maximum frequency [Hz] | 60.00 | ○ | |
| 37 | 0h1525 | Time constant of V0 input filter | 0–9999 | 10 | ○ | p.62 , p.68 |
| 38 | 0h1526 | V0 Minimum input voltage | 0.00–V0 Maximum input voltage [V] | 0.00 | ○ | p.62 , p.68 , p.135 |
| 39 | 0h1527 | Frequency corresponding to V0 minimum input voltage | 0.00–Maximum frequency [Hz] | 0.00 | ○ | p.62 , p.68 , p.135 |
| 40 | 0h1528 | V0 Maximum input voltage | V0 Minimum input voltage–5.00 [V] | 5.00 | ○ | |
| 41 | 0h1529 | Frequency corresponding to V0 maximum input voltage | 0.00–Maximum frequency [Hz] | 60.00 | ○ | |

* Settings can be changed during the inverter operation.

Table of Functions

| Display | Comm. Address | Name | Setting Range | Initial Value | Property* | Page |
|------------------|---------------|----------------------------------------------------|------------------------------------|---------------|-----------|--------------------------------------------------------------|
| 52 ¹⁾ | 0h1534 | I input filter time constant | 0–9999 | 10 | ○ | <u>p.62,</u> <u>p.71,</u> <u>p.72</u> |
| 53 ¹⁾ | 0h1535 | I minimum input current | 0.00–I maximum input current [mA] | 4.00 | ○ | <u>p.62,</u> <u>p.71,</u> <u>p.73,</u> <u>p.135</u> |
| 54 ¹⁾ | 0h1536 | Frequency corresponding to I minimum input current | 0.00–Maximum frequency [Hz] | 0.00 | ○ | <u>p.62,</u> <u>p.71,</u> <u>p.72</u> |
| 55 ¹⁾ | 0h1537 | I maximum input current | I minimum input current–20.00 [mA] | 20.00 | ○ | |
| 56 ¹⁾ | 0h1538 | Frequency corresponding to I maximum input current | 0.00–Maximum frequency [Hz] | 60.00 | ○ | |
| 57 ¹⁾ | 0h1539 | V input filter time constant | 0– 9999 | 10 | ○ | <u>p.62,</u> <u>p.72,</u> <u>p.73</u> |
| 58 ¹⁾ | 0h153A | V minimum input voltage | 0.00–V maximum input voltage [V] | 0.00 | ○ | <u>p.62,</u> <u>p.71,</u> <u>p.73,</u> <u>p.135</u> |
| 59 ¹⁾ | 0h153B | Frequency corresponding to V minimum input voltage | 0.00–Maximum frequency [Hz] | 0.00 | ○ | |
| 60 ¹⁾ | 0h153C | V maximum input voltage | V minimum input voltage–10.00 [V] | 10.00 | ○ | |
| 61 ¹⁾ | 0h153D | Frequency corresponding to V maximum input voltage | 0.00–Maximum frequency [Hz] | 60.00 | ○ | |

1) Available only for models equipped with advanced I/O.

* Settings can be changed during the inverter operation.

| Display | Comm. Address | Name | Setting Range | | Initial Value | Property * | Page | |
|--------------------|----------------------------------------|---------------------------------------------------|------------------------------------|----------------------------------------------|---------------|------------|------|---------------------------------|
| 65 ²⁾ | 0h1541 | Multi-function input terminal P1 function setting | 0 | Forward run command (FX) | 0 | X | | |
| | | | 1 | Reward run command (RX) | | | | |
| | | | 2 | Emergency stop (Emergency Stop Trip) | | | | |
| | | | 3 | Reset when fault trip occurs (RESET) | | | | |
| 66 ²⁾ | 0h1542 | Multi-function input terminal P2 function setting | 4 | Jog operation command (JOG) | 1 | | | |
| | | | 5 | Multi-step speed –low | | | | |
| | | | 6 | Multi-step speed –middle | | | | |
| | | | 7 | Multi-step speed –high | | | | |
| | | | 8 | Multi-step acc/dec –low | | | | |
| | | | 9 | Multi-step acc/dec –middle | | | | |
| 67 ²⁾ | 0h1543 | Multi-function input terminal P3 function setting | 10 | Multi-step acc/dec –high | 2 | | | |
| | | | 11 | DC braking during stop command | | | | |
| | | | 12 | 2nd motor selection | | | | |
| | | | 13 | -Reserved- | | | | |
| 68 ¹⁾²⁾ | 0h1544 | Multi-function input terminal P4 function setting | 14 | -Reserved- | 3 | | | |
| | | | 15 | Up-down operation function | | | | Frequency increase command (UP) |
| | | | Frequency reduction command (DOWN) | | | | | |
| 69 ¹⁾²⁾ | 0h1545 | Multi-function input terminal P5 function setting | 16 | | 4 | | | |
| | | | 17 | 3-wire operation | | | | |
| | | | 18 | External trip signal input: A terminal (EtA) | | | | |
| | | | 19 | External trip signal input: B terminal (EtB) | | | | |
| | | | 20 | -Reserved- | | | | |
| | | | 21 | Transition from PID to general operation | | | | |
| | | | 22 | 2nd Source | | | | |
| | | | 23 | Fix analog command frequency | | | | |
| | | | 24 | Acceleration/deceleration stop command | | | | |
| | | | 25 | Initialize saved up-down frequency | | | | |
| 26 | Jog forward operation command (JOG-FX) | | | | | | | |
| 27 | Jog reverse operation command (JOG-RX) | | | | | | | |

[p.62](#),
[p.78](#),
[p.110](#),
[p.112](#),
[p.116](#),
[p.132](#),
[p.164](#)

Table of Functions

1) Available only for models equipped with advanced I/O.

2) Refer to 10 Troubleshooting on page 217 for the external trip signal input display in In65–69. Do not set two or more multi-function input terminals to the same function.

* Settings can be changed during the inverter operation.

| Display | Comm. Address | Name | Setting Range | | Initial Value | Property* | Page | | | | | | | | | | | | | | | | |
|---------|---------------|----------------------------------------------------|---------------------------------------------------------------------------------------------------------------------------------------------------------------------------------------------------------------------------------------------------------------------------------------------------------------------------------------------------------------------------------------------------------------------------------------------------------------|----------------|-------------------------|-----------|----------------------|----|----|----|------|------|------|------|------|----|----|----|----|----|---|---|-------------------------------------------------|
| 70 | 0h1546 | PNP/NPN selection switch | 0 | PNP | - | - | - | | | | | | | | | | | | | | | | |
| | | | 1 | NPN | | | | | | | | | | | | | | | | | | | |
| 85 | 0h1555 | Multi-function input terminal filter time constant | 1–15 | | 4 | O | p.62 | | | | | | | | | | | | | | | | |
| 87 | 0h1557 | Multi-function input contact selection | P5 – P1 | | 0 0000 ³⁾ | X | - | | | | | | | | | | | | | | | | |
| | | | 0 | A contact (NO) | | | | | | | | | | | | | | | | | | | |
| | | | 1 | B contact (NC) | | | | | | | | | | | | | | | | | | | |
| 90 | 0h155A | Input terminal block status display | <table border="1"> <tr> <td>BIT2</td> <td>BIT1</td> <td>BIT0</td> </tr> <tr> <td>P3</td> <td>P2</td> <td>P1</td> </tr> </table> <p>P1 to P3 are displayed for models equipped with standard I/O.</p> <table border="1"> <tr> <td>BIT4</td> <td>BIT3</td> <td>BIT2</td> <td>BIT1</td> <td>BIT0</td> </tr> <tr> <td>P5</td> <td>P4</td> <td>P3</td> <td>P2</td> <td>P1</td> </tr> </table> <p>P1 to P5 are displayed for models equipped with advanced I/O.</p> | | BIT2 | BIT1 | BIT0 | P3 | P2 | P1 | BIT4 | BIT3 | BIT2 | BIT1 | BIT0 | P5 | P4 | P3 | P2 | P1 | - | - | p.39 , p.161 |
| BIT2 | BIT1 | BIT0 | | | | | | | | | | | | | | | | | | | | | |
| P3 | P2 | P1 | | | | | | | | | | | | | | | | | | | | | |
| BIT4 | BIT3 | BIT2 | BIT1 | BIT0 | | | | | | | | | | | | | | | | | | | |
| P5 | P4 | P3 | P2 | P1 | | | | | | | | | | | | | | | | | | | |

3) The initial value will be displayed on the keypad as .

* Settings can be changed during the inverter operation.

9.7 Output Terminal Block Function group (PAR→OU)

| Display | Comm. Address | Name | Setting Range | | Initial Value | Property* | Page |
|---------|---------------|--------------------------------|-----------------------|----------------------------------------------------------------------------|---------------|-----------|------------------------------------------------|
| 00 | x | Jump Code | 0–58 | | 30 | O | p.43 |
| 01 | 0h1601 | Analog output item setting | Parameter setting | Output item corresponding to 10 [V] | 0 | O | p.142 |
| | | | 0 Output frequency | Maximum frequency (FrM) | | | |
| | | | 1 Current | 150 [%] or inverter's rated current | | | |
| | | | 2 Output voltage | AC 282 V | | | |
| | | | 3 Inverter DC voltage | DC 410 V | | | |
| 02 | 0h1602 | Analog output level adjustment | 10–200 [%] | | 100 | O | |
| 30 | 0h161E | Fault output setting | bit | 000–111 | 010 | O | p.39, p.143 |
| | | | --1 | Operation when low voltage trip occurs | | | |
| | | | -1- | Operation when fault trip other than low voltage trip occurs | | | |
| | | | 1-- | Operation when number of automatic restarts after fault trip (Pr09) is set | | | |

* Settings can be changed during the inverter operation.

Table of Functions

| Display | Comm. Address | Name | Setting Range | | Initial Value | Property* | Page |
|---------|----------------------|-----------------------------------------------|--------------------------------|-------------------------------------|------------------|-----------|-----------------------------------------------------------------------------------------------------------------------------------------------------------------------------------------------------------------------------------------------|
| 31 | 0h161F | Multi-function relay setting | 0 | FDT-1 | 17 | O | p.127 , p.140 , p.150 , p.143 , p.161 , p.162 , p.165 , p.166 , p.218 |
| | | | 1 | FDT-2 | | | |
| | | | 2 | FDT-3 | | | |
| | | | 3 | FDT-4 | | | |
| | | | 4 | FDT-5 | | | |
| | | | 5 | Overload (OL) | | | |
| | | | 6 | Inverter Overload (IOL) | | | |
| | | | 7 | Motor stall (STALL) | | | |
| | | | 8 | Over voltage (Ovt) | | | |
| | | | 9 | Low voltage (Lvt) | | | |
| | | | 10 | Inverter cooling fan overheat (OHt) | | | |
| | | | 11 | Lost command | | | |
| | | | 12 | Run | | | |
| | | | 13 | Stop | | | |
| | | | 14 | At constant speed | | | |
| | | | 15 | Speed search | | | |
| | | | 16 | Ready | | | |
| | | | 17 | Fault output setting | | | |
| | | | 18 | Abnormal cooling fan alarm | | | |
| 19 | Brake signal setting | | | | | | |
| 32 | 0h1620 | Multi-function output 2 feature selection | Same as OU31 | | 12 | O | |
| 41 | 0h1629 | Output terminal block status display | BIT1 | BIT0 | 00 | O | p.39 , p.154 |
| | | | Relay2 / Open collector output | Relay1 | | | |
| 52 | 0h1634 | Multi-function output/relay contact selection | Q1, Relay1 | | 00 ¹⁾ | X | - |
| | | | 0 | A contact (NO) | | | |
| | | | 1 | B Contact (NC) | | | |
| 57 | 0h1639 | Detection frequency | 0.00–Maximum frequency [Hz] | | 30.00 | O | p.143 |
| 58 | 0h163A | Detection frequency band | | | 10.00 | O | |

1) The initial value will be displayed on the keypad as .

* Settings can be changed during the inverter operation.

9.8 Communication Function group (PAR→CM)

| Display | Comm. Address | Name | Setting Range | Initial Value | Property* | Page |
|---------|---------------|--------------------------------|-------------------------------------------------------------------------------------------------------------------------|---------------|-----------|---------------------------------------------|
| 00 | x | Jump Code | 0–58 | 31 | O | <u>p.43</u> |
| 01 | 0h1701 | Inverter station ID | 1–250 | 1 | O | <u>p.76,</u> <u>p.83</u> <u>p.173</u> |
| 02 | 0h1702 | Communication protocol setting | 0 Modbus RTU 1 LS INV 485 | 0 | X | |
| 03 | 0h1703 | Communication speed | 0 1,200 [bps] 1 2,400 [bps] 2 4,800 [bps] 3 9,600 [bps] 4 19,200 [bps] 5 38,400 [bps] | 3 | O | |
| 04 | 0h1704 | Parity/stop bit setting | 0 Parity: None, Stop Bit: 1 1 Parity: None, Stop Bit: 2 2 Parity: Even, Stop Bit: 1 3 Parity: Odd, Stop Bit: 1 | 0 | O | <u>p.173</u> |
| 05 | 0h1705 | Communication time setting | 2–100 [ms] | 5 | O | |
| 31 | 0h171F | Read address registration 1 | 0000–A4FF | 000A | O | <u>p.176</u> |
| 32 | 0h1720 | Read address registration 2 | | 000E | | |
| 33 | 0h1721 | Read address registration 3 | | 000F | | |
| 34 | 0h1722 | Read address registration 4 | | 0000 | | |
| 35 | 0h1723 | Read address registration 5 | 0000–A4FF | 0000 | O | |
| 36 | 0h1724 | Read address registration 6 | | 0000 | | |
| 37 | 0h1725 | Read address registration 7 | | 0000 | | |
| 38 | 0h1726 | Read address registration 8 | | 0000 | | |
| 51 | 0h1733 | Write address registration 1 | 0000–A4FF | 0005 | O | |
| 52 | 0h1734 | Write address registration 2 | | 0006 | | |
| 53 | 0h1735 | Write address registration 3 | | 0000 | | |
| 54 | 0h1736 | Write address registration 4 | | 0000 | | |

Table of Functions

| Display | Comm. Address | Name | Setting Range | Initial Value | Property* | Page |
|---------|---------------|------------------------------|---------------|---------------|-----------|------|
| 55 | 0h1737 | Write address registration 5 | | 0000 | | |
| 56 | 0h1738 | Write address registration 6 | | 0000 | | |
| 57 | 0h1739 | Write address registration 7 | | 0000 | | |
| 58 | 0h173A | Write address registration 8 | | 0000 | | |

* Available only for models equipped with advanced I/O.

* Settings can be changed during the inverter operation.

9.9 Application Function group (PAR→AP)

| Display | Comm. Address | Name | Setting Range | | Initial Value | Property* | Page |
|------------------|---------------|----------------------------|----------------|-------------------------------------------|---------------|-----------|--------------|
| 00 | x | Jump Code | 0–71 | | 20 | O | <u>p.43</u> |
| 01 | 0h1801 | PID control setting | 0 | No | 0 | X | <u>p.121</u> |
| | | | 1 | Yes | | | |
| 02 ¹⁾ | 0h1802 | PID control unit selection | 0 | Frequency [Hz] | 0 | X | |
| | | | 1 | Percentage [%] | | | |
| 18 ¹⁾ | 0h1812 | Amount of PID feedback | When AP 2 is 0 | Frequency display range: 0.00–400.00 [Hz] | - | - | |
| | | | When AP 2 is 1 | Percentage display range: 0.0–100.0 [%] | | | |
| 19 ¹⁾ | 0h1813 | PID reference | When AP 2 is 0 | 0.00–Maximum frequency [Hz] | 0.00 | O | |
| | | | When AP 2 is 1 | 0.0–100.0 [%] | | | |
| 20 ¹⁾ | 0h1814 | PID reference setting | 0 | Keypad 1 | 0 | X | <u>p.121</u> |
| | | | 1 | Keypad 2 | | | |
| | | | 2 | V1: 0–10 [V] | | | |
| | | | 3 | I2(I): 0–20 [mA] ²⁾ | | | |
| | | | 4 | I2(V): 0–10 [V] ²⁾ | | | |
| 21 ¹⁾ | 0h1815 | PID feedback setting | 0 | I2(I) (0–20 [mA]) ²⁾ | 2 | X | |
| | | | 1 | I2(V) (0–10 [V]) ²⁾ | | | |
| | | | 2 | V1 (0–10 [V]) | | | |
| | | | 3 | RS-485 communication ²⁾ | | | |

Table of Functions

| Display | Comm. Address | Name | Setting Range | Initial Value | Property* | Page | |
|------------------|---------------|----------------------------------------------|----------------------------------------------------------|------------------------------------------------------|-----------|--------------|---|
| 22 ¹⁾ | 0h1816 | PID controller P gain | 0.0–999.9 [%] | 300.0 | O | <u>p.121</u> | |
| 23 ¹⁾ | 0h1817 | PID controller integral time (I gain) | 0.10–32.00 [s] | 1.00 | O | | |
| 24 ¹⁾ | 0h1818 | PID controller differentiation time (D gain) | 0.00–30.00 [s] | 0.00 | O | | |
| 28 ¹⁾ | 0h181C | PID control mode setting | 0 | Normal PID control | 0 | | X |
| | | | 1 | Process PID control | | | |
| 29 ¹⁾ | 0h181D | PID output upper limit frequency | PID output lower limit frequency–maximum frequency [Hz] | 60.00 | O | | |
| 30 ¹⁾ | 0h181E | PID output lower limit frequency | Starting frequency–PID output upper limit frequency [Hz] | 0.50 | O | | |
| 37 ¹⁾ | 0h1825 | Sleep delay time | 0.0–2000.0 [s] | 60.0 | X | | |
| 38 ¹⁾ | 0h1826 | Sleep frequency | 0.00–Maximum frequency [Hz] | 0.00 | O | | |
| 39 ¹⁾ | 0h1827 | Wake-up (Wake-up) level | 0.0–100.0 [%] | 35.0 | O | | |
| 70 | 0h1846 | Draw operation mode selection | 0 | Do not use draw operation | 0 | X | |
| | | | 1 | V1(0–10 [V]) input draw operation | | | |
| | | | 2 | V0 (0–5 [V]) input draw operation | | | |
| | | | 3 | I2(I) (0–20 [mA]) input draw operation ²⁾ | | | |
| | | | 4 | I2(V) (0–10 [V]) input draw operation ²⁾ | | | |
| 71 | 0h1816 | Draw percentage | 0.0–100.0 [%] | 0.0 | O | <u>p.148</u> | |

1) Displayed only when AP01 (PID control setting) is set to 1.

2) Available only for models equipped with advanced I/O.

* Settings can be changed during the inverter operation.

9.10 Protection Function group (PAR→Pr)

| Display | Comm. Address | Name | Setting Range | Initial Value | Property* | Page | |
|---------|---------------|-----------------------------------------------|---------------|------------------------------------------------------|-----------|-----------------------|--------------------------------------------------|
| 00 | x | Jump Code | 0–96 | 40 | O | p.43 | |
| 05 | 0h1905 | Output open-phase protection setting | 0 | No | 0 | O | p.163 , p.217 |
| | | | 1 | Yes | | | |
| 08 | 0h1908 | Operation on reset after fault trip | 0 | No | 0 | O | p.85 |
| | | | 1 | Yes | | | |
| 09 | 0h1909 | Number of automatic restarts after fault trip | 0–10 [times] | 0 | O | p.129 | |
| 10 | 0h190A | Automatic restart delay time after fault trip | 0.0–60.0 [s] | 1.0 | O | | |
| 12 | 0h190C | Motion at speed command loss | 0 | Continue to run at frequency before the command loss | 0 | O | p.166 , p.175 |
| | | | 1 | Free run stop (output block) | | | |
| | | | 2 | Deceleration stop | | | |
| 13 | 0h190D | Time to decide speed command loss | 0.1–120.0[s] | 1.0 | O | | |
| 15 | 0h190F | Time to determine analog speed command loss | 0 | Not operating | 0 | O | p.166 |
| | | | 1 | Operating at half of the set value | | | |
| | | | 2 | Operating under the set value | | | |

* Settings can be changed during the inverter operation.

Table of Functions

| Display | Comm. Address | Name | Setting Range | Initial Value | Property* | Page | |
|--------------------|---------------|-----------------------------------------------|-------------------------------------------------------|---------------------------------------------------|-----------|-------------------------------|-----------------------------------------------|
| 18 ¹⁾ | 0h1912 | Overload alarm level | 30–150 [%] | 150 | O | <u>p.161</u> | |
| 19 | 0h1913 | Overload warning time | 0.0–30.0 [s] | 10.0 | O | | |
| 20 | 0h1914 | Overload warning selection | 0 | No | 1 | O | <u>p.161,</u> <u>p.218</u> |
| | | | 1 | Block inverter output when overloaded | | | |
| 21 ²⁾ | 0h1915 | Overload fault level | 30–200 [%] | 180 | O | <u>p.161,</u> <u>p.220</u> | |
| 22 ²⁾ | 0h1916 | Overload fault time | 0.0–60.0 [s] | 60.0 | O | <u>p.161</u> | |
| 40 | 0h1928 | ETH selection | 0 | No | 0 | O | <u>p.159,</u> <u>p.217</u> |
| | | | 1 | Yes | | | |
| 41 ³⁾ | 0h1929 | Motor cooling type | 0 | General motor that cooler is attached to its axis | 0 | O | <u>p.159</u> |
| | | | 1 | Motor that supplies separate power to the cooler | | | |
| 42 ³⁾ | 0h192A | Electronic thermal 1 minute level | Electronic thermal continuous operation level–200 [%] | 150 | O | <u>p.159</u> | |
| 43 ³⁾⁴⁾ | 0h192B | Electronic thermal continuous operation level | 50–Electronic thermal 1 minute level [%] | 100 | O | <u>p.159</u> | |
| 50 | 0h1932 | Stall prevention selection | bit | 000–111 | 000 | X | <u>p.39,</u> <u>p.135,</u> <u>p.162</u> |
| | | | --1 | Prevent stall when accelerating | | | |
| | | | -1- | Prevent stall when running at a constant speed | | | |
| | | | 1-- | Prevent stall when decelerating | | | |
| 52 | 0h1934 | Stall prevention level | 30–200 [%] | 150 | X | <u>p.162</u> | |

1) Multi-function output

2) Displayed only when Pr20 (Overload warning selection) is set to 1.

3) Displayed only when Pr40 (ETH selection) is set to 1.

4) The value cannot be set to 150% or more.

* Settings can be changed during the inverter operation.

| Display | Comm. Address | Name | Setting Range | | Initial Value | Property* | Page |
|------------------------|---------------|---------------------------------------------------------------|--------------------------------------|---------------------------------------------|---------------|-----------|-------------------------------------------------|
| 53 ⁵⁾ | 0h1935 | Voltage limit when using stall prevention during deceleration | 0 | No | 0 | X | p.135 |
| | | | 1 | Yes | | | |
| 65 | 0h1941 | DB resistor warning level limit setting | 0 | Use DB resistor without level limit | 1 | O | p.168 |
| | | | 1 | Use DB resistor during the time set at Pr66 | | | |
| 66 ⁶⁾ | 0h1942 | DB resistor warning level | 0–30 [%] | | 10 | O | |
| 79 | 0h194F | Operation at fan fault | 0 | Run continuously | 1 | O | p.150, p.143 |
| | | | 1 | Stop operation | | | |
| 80 ^{7) 8) 9)} | 0h1950 | Initial charging circuit trip protection | 0 | Not use ROT function | 1 | x | p.170 |
| | | | 1 | Use ROT function1 | | | |
| 91 | 0h195B | Fault history 1 | Types and information of fault trips | | nOn | - | p.156, p.217 |
| 92 | 0h195C | Fault history 2 | | | | | |
| 93 | 0h195D | Fault history 3 | | | | | |
| 94 | 0h195E | Fault history 4 | | | | | |
| 95 | 0h195F | Fault history 5 | | | | | |
| 96 | 0h1960 | Fault history deletion | 0 | Maintain history | 0 | O | |
| | | | 1 | Delete history | | | |

5) Displayed only when Pr50 (Stall prevention selection) is set to 2 or 1.

6) Displayed only when Pr65 (DB resistor warning level limit setting) is set to 1.

7) Switching status of Pr80: [Use ROT function, , [Not use Rot function, , [Initial value,

8) The Pr80 function can be used only when the input power is 0.4–2.2 kW.

9) There is a possibility of ROT trip when power is turned on within 1 second after LVT trip due to power OFF..

* Settings can be changed during the inverter operation.

9.11 2nd Motor Function group (PAR→M2)

| Display | Comm. Address | Name | Setting Range | Initial Value | Property* | Page | |
|---------|---------------|---------------------------------------------------------|-----------------------------------------------------------------|------------------|-----------|--------------|---|
| 00 | X | Jump Code | 0–30 | 12 | O | <u>p.43</u> | |
| 04 | 0h1A04 | 2nd motor acceleration time | 0.0–6000.0 [s] ¹⁾ | 5.0 | O | <u>p.131</u> | |
| 05 | 0h1A05 | 2nd motor deceleration time | | 10.0 | O | | |
| 07 | 0h1A07 | 2nd motor base frequency | 30.00–Maximum frequency [Hz] | 60.00 | X | | |
| 12 | 0h1A0C | 2nd motor rated current | 0.1–100.0 [A] | - | X | | |
| 25 | 0h1A19 | 2nd motor V/F pattern | 0 | Linear | 0 | | X |
| | | | 1 | Square reduction | | | |
| | | | 2 | User V/F | | | |
| 26 | 0h1A1A | 2nd motor forward torque boost | 0.0–15.0 [%] | 4.0 | X | | |
| 27 | 0h1A1B | 2nd motor reverse torque boost | | 4.0 | X | | |
| 28 | 0h1A1C | 2nd motor stall prevention level | 30–150 [%] | 150 | X | | |
| 29 | 0h1A1D | 2nd motor electronic thermal 1 minute level | 2nd motor electronic thermal continuous operation level–200 [%] | 150 | O | | |
| 30 | 0h1A1E | 2nd motor electronic thermal continuous operation level | 50–2nd motor electronic thermal 1 minute level [%] | 100 | O | | |

* This group is displayed only when one of multi-function input terminal features (standard I/O models: In65– 67, advanced I/O models: In65– 69) is set to 12 (2nd motor selection).

* Settings can be changed during the inverter operation.

1) The setting range varies depending on the set value of the bA08 code.

9.12 Config Mode group (PAR→CF)

| Display | Comm. Address | Name | Setting Range | Initial Value | Property* | Page | |
|---------|--------------------|------------------------|--------------------------------------------|---------------|-----------|------------------------------------------------|-----------------------------------------|
| 00 | x | Jump Code | 0–95 | 1 | 0 | p.43 , p.52 | |
| 01 | 0h1B01 | Display after power on | Items that are displayed after power is on | 0 | 0 | p.151 | |
| | | | 0 | | | | Command Frequency |
| | | | 1 | | | | Acceleration time |
| | | | 2 | | | | Deceleration time |
| | | | 3 | | | | Command source |
| | | | 4 | | | | Frequency setting method |
| | | | 5 | | | | Motor selection |
| | | | 6 | | | | Rated motor current |
| | | | 7 | | | | Base frequency |
| | | | 8 | | | | Maximum frequency |
| | | | 9 | | | | Output voltage adjustment |
| | | | 10 | | | | Forward boost |
| | | | 11 | | | | Reverse boost |
| | | | 12 | | | | Output current |
| | | | 13 | | | | Motor RPM |
| | | | 14 | | | | Inverter DC voltage |
| | | | 15 | | | | User select signal (code, dr81 setting) |
| | | | 16 | | | | Currently out of order |
| 17 | Open hidden groups | | | | | | |
| 02 | 0h1B02 | I/O Type | 0 | Standard I/O | - | - | |
| | | | 1 | Advanced I/O | | | - |

* Settings can be changed during the inverter operation.

Table of Functions

| Display | Comm. Address | Name | Setting Range | | Initial Value | Property* | Page |
|---------|---------------|--------------------------|--------------------------|----------------------------------------------|---------------|-----------|-----------------------------------------------|
| 79 | 0h1B4F | Software version | Inverter program version | | - | - | - |
| 80 | 0h1B50 | I/O board version | I/O board version | | - | - | - |
| 93 | 0h1B5D | Parameter initialization | 0 | Do not initialize | 0 | X | p.52 p.136 |
| | | | 1 | Initialize all | | | |
| | | | 2 | Initialize operation group | | | |
| | | | 3 | Initialize drive (dr) group | | | |
| | | | 4 | Initialize basic function (bA) group | | | |
| | | | 5 | Initialize expanded function (Ad) group | | | |
| | | | 6 | Initialize control function (Cn) group | | | |
| | | | 7 | Initialize input terminal block (In) group | | | |
| | | | 8 | Initialize output terminal block (OU) group | | | |
| | | | 9 | Initialize communication function (CM) group | | | |
| | | | 10 | Initialize application function (AP) group | | | |
| | | | 11 | Initialize protection function (Pr) group | | | |
| | | | 12 | Initialize 2nd motor function (M2) group | | | |
| | | | 13 | Initialize config mode (CF) group | | | |
| 94 | 0h1B5E | Password registration | 0000–FFFF | | 0000 | O | p.136 |
| 95 | 0h1B5F | Parameter lock | UL (Unlock) | Unlock parameter | UL | O | |
| | | | L (Lock) | Lock parameter | | | |

* Settings can be changed during the inverter operation.

10 Troubleshooting

This chapter explains how to troubleshoot a problem when inverter protective functions, fault trips, warning signals, or a fault occurs. If the inverter does not work normally after following the suggested troubleshooting steps, please contact the LS ELECTRIC customer service center.

10.1 Trips

When the inverter detects a fault, it stops the operation (trips) or sends out a warning signal. When a trip or warning occurs, the keypad displays the information. Users can read the warning message at Pr91–Pr95. When more than 2 trips occur at roughly the same time, the keypad (basic keypad with 7-segment display) displays the higher priority fault trip information.

The fault conditions can be categorized as follows:

- **Level:** When the fault is corrected, the trip or warning signal disappears and the fault is not saved in the fault history.
- **Latch:** When the fault is corrected and a reset input signal is provided, the trip or warning signal disappears.
- **Fatal:** When the fault is corrected, the fault trip or warning signal disappears only after the user turns off the inverter, waits until the charge indicator light goes off, and turns the inverter on again. If the inverter is still in a fault condition after powering it on again, please contact the supplier or the LS ELECTRIC customer service center.

10.1.1 Fault Trips



Protection Functions for Output Current and Input Voltage

| Keypad Display | Item | Type | Description |
|----------------|-------------------------|-------|----------------------------------------------------------------------------------------------------------------------------------------------------------------------------------------------------------|
| | OLt (Over Load) | Latch | Displayed when the motor overload trip is activated and the actual load level exceeds the set level. Operates when Pr20 is set to a value other than 0. |
| | OCT (Over Current) | Latch | Displayed when inverter output current exceeds 200% of the rated current. |
| | Ovt (Over Voltage) | Latch | Displayed when internal DC circuit voltage exceeds the specified value. |
| | Lvt (Low Voltage) | Level | Displayed when internal DC circuit voltage is less than the specified value. |
| | GFT (Ground Trip) | Latch | Displayed when a ground fault trip occurs on the output side of the inverter and causes the current to exceed the specified value. The specified value varies depending on inverter capacity. |
| | EtH (E-Thermal) | Latch | Displayed based on inverse time-limit thermal characteristics to prevent motor overheating. Operates when Pr40 is set to a value other than 0. |
| | OPO (Out Phase Open) | Latch | Displayed when a 3-phase inverter output has one or more phases in an open circuit condition. Operates when bit 1 of Pr05 is set to 1. |
| | IOL (Inverter OLT) | Latch | Displayed when the inverter has been protected from overload and resultant overheating, based on inverse time-limit thermal characteristics. Allowable overload rate for the inverter is 150% for 1 min. |
| | rOt | Fatal | Displayed when the input power is unstable or an initial charging circuit trip occurs while supplying power to the inverter. ¹⁾²⁾ |

1) The 'rOt' t rip occurs only in the 0.4–2.2 kW models.

2) There is a possibility of ROT trip when power is turned on within 1 second after LVT trip due to power OFF.

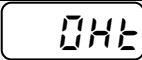
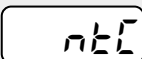
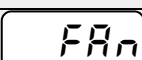
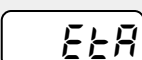
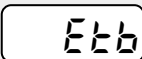
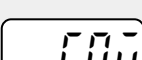
Protection Functions Using Abnormal Internal Circuit Conditions and External Signals

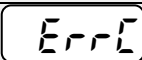
| Keypad Display | Item | Type | Description |
|------------------------------------------------------------------------------------------------------------------------------------------------------------------------|--------------------------------|-------|-------------------------------------------------------------------------------------------------------------------------------------------------------------------------------------------------------------------------------------------------------------------------------------------------------------------------------------------------------------------------------------------------------------------------------------------------------------------------------------------------------------------------------|
|  | OHT (Over Heat) | Latch | Displayed when the temperature of the inverter heat sink exceeds the specified value. |
|  | ntC (NTC Open) | Latch | Displayed when an error is detected in the temperature sensor of the Insulated Gate Bipolar Transistor (IGBT). |
|  | FAn (Fan Trip) | Latch | Displayed when an error is detected in the cooling fan ²⁾ . |
|   | EtA,EtB (External Trip A,B) | Latch | When the multi-function input terminal of the I/O is set to EtA or EtB, the input terminal is used as the signal. <ul style="list-style-type: none"> EtA is displayed when the CM and short signal are generated when the multi-function input is NPN or P24 and the short signal is generated when multi-function input is PNP. EtB is displayed when the CM and open signal are generated when multi-function input is NPN or P24 and open signal is generated when multi-function input is PNP. |
|  | COM (Communication trip) | Latch | Displayed when communication between the Main DSP and the IO CPU is disconnected for more than 500 ms. |
|  | nbr | Latch | Displayed when the inverter's output current is below the value set at Ad41 during the external brake signal operation based on the multi-function terminal function setting. Set OU31 or OU32 to 19 (Brake signal setting). |
|  | IO Board Trip | Latch | Displayed when supplying power to the inverter and continuously displayed when communication is disconnected after supplying power. |
|  | | | Displayed when communication is disconnected for more than 2 seconds after connected normally. |

2) The cooling fan trip can be occurred when it is overloaded, its connectors are disconnected, or its components break. When the problems are solved, Fan Trip is cleared and the fan operates normally.

10.2 Troubleshooting Fault Trips

When a fault trip or warning occurs due to a protection function, refer to the following table for possible causes and remedies.

| Item | Cause | Remedy |
|-----------------------|-------------------------------------------------------------------------------------------------------------------|--------------------------------------------------------------------------------------------------------------|
| OLt (Over Load) | The load is greater than the motor's rated capacity. | Ensure that the motor and inverter have appropriate capacity ratings. |
| | The set value for the overload trip level (Pr21) is too low. | Increase the set value for the overload trip level. |
| OQt (Over Current) | Acc/Dec time is too short, compared to load inertia (bA16). | Increase Acc/Dec time. |
| | The inverter load is greater than the rated capacity. | Replace the inverter with a model that has increased capacity. |
| | The inverter supplied an output while the motor was idling. | Operate the inverter after the motor has stopped or use the speed search function (Cn71). |
| | The mechanical brake of the motor is operating too fast. | Check the mechanical brake. |
| Ovt (Over Voltage) | Deceleration time is too short for the load inertia (bA16). | Increase the acceleration time. |
| | A generative load occurs at the inverter output. | Use the braking unit. |
| | The input voltage is too high. | Determine if the input voltage is above the specified value. |
| Lvt (Low Voltage) | The input voltage is too low. | Determine if the input voltage is below the specified value. Adjust the bA19 (Inverter input voltage) value. |
| | A load greater than the power capacity is connected to the system (e.g., a welder, direct motor connection, etc.) | Increase the power capacity. |
| | The magnetic contactor connected to the power source has a faulty connection. | Replace the magnetic contactor. |
| GFt (Ground Trip) | A ground fault has occurred in the inverter output wiring. | Check the output wiring. |
| | The motor insulation is damaged. | Replace the motor. |

| Item | Cause | Remedy |
|--------------------------|---------------------------------------------------------------------------------------------------------------|---------------------------------------------------------------------------------------------------------------------------------------------------------|
| EtH (E-Thermal) | The motor has overheated. | Reduce the load or operation frequency. |
| | The inverter load is greater than the rated capacity. | Replace the inverter with a model that has increased capacity. |
| | The inverter has been operated at low speed for an extended duration. | Replace the motor with a model that supplies extra power to the cooling fan. |
| OPO (Out Phase Open) | The magnetic contactor on the output side has a connection fault. | Check the magnetic contactor on the output side. |
| | The output wiring is faulty. | Check the output wiring. |
| IOL (Inverter OLT) | The load is greater than the rated motor capacity. | Replace the motor and inverter with models that have increased capacity. |
| | The torque boost level is too high. | Reduce the torque boost level. |
| OHT (Over Heat) | There is a problem with the cooling system. | Determine if a foreign object is obstructing the air inlet, outlet, or vent. |
| | The inverter cooling fan has been operated for an extended period. | Replace the cooling fan. |
| | The ambient temperature is too high. | Keep the ambient temperature below 50°C. |
| ntC (NTC Open) | The ambient temperature is too low. | Keep the ambient temperature above -10°C. |
| | There is a fault with the internal temperature sensor. | Contact the retailer or the LS ELECTRIC customer service center. |
| FAn (Fan Trip) | A foreign object is obstructing the fan's air vent. | Remove the foreign object from the air inlet or outlet. |
| | The cooling fan needs to be replaced. | Replace the cooling fan. |
| rOt (Relay Open Trip) | The input power is unstable or an initial charging circuit trip occurs while supplying power to the inverter. | Turn off and on the power again. If the problem continues, stop using the inverter and contact the retailer or the LS ELECTRIC customer service center. |

10.3 Troubleshooting Other Faults

When a fault other than those identified as fault trips or warnings occurs, refer to the following table for possible causes and remedies.

| Item | Cause | Remedy |
|------------------------------------|--------------------------------------------------|-------------------------------------------------------------------------|
| Parameters cannot be set. | The inverter is in operation (driving mode). | Stop the inverter to change to program mode and set the parameter. |
| | The parameter access is incorrect. | Check the correct parameter access level and set the parameter. |
| | The password is incorrect. | Check the password, disable the parameter lock and set the parameter. |
| | Low voltage is detected. | Check the power input to resolve the low voltage and set the parameter. |
| The motor does not rotate. | The frequency command source is set incorrectly. | Check the frequency command source setting. |
| | The operation command source is set incorrectly. | Check the operation command source setting. |
| | Power is not supplied to the terminal R/S/T. | Check the terminal connections R/S/T and U/V/W. |
| | The charge lamp is turned off. | Turn on the inverter. |
| | The operation command is off. | Turn on the operation command (RUN). |
| | The motor is locked. | Unlock the motor or lower the load level. |
| | The load is too high. | Operate the motor independently. |
| An emergency stop signal is input. | Reset the emergency stop signal. | |

| Item | Cause | Remedy |
|-------------------------------------------------------------|---------------------------------------------------------------------------------------------------------------------------------------------------------------------------------------|-------------------------------------------------------------------------------------------------|
| The motor does not rotate. | The wiring for the control circuit terminal is incorrect. | Check the wiring for the control circuit terminal. |
| | The input option for the frequency command is incorrect. | Check the input option for the frequency command. |
| | The input voltage or current for the frequency command is incorrect. | Check the input voltage or current for the frequency command. |
| | The PNP/NPN mode is selected incorrectly. | Check the PNP/NPN mode setting. |
| | The frequency command value is too low. | Check the frequency command and input a value above the starting frequency (dr19). |
| | The [STOP] key is pressed. | Check that the stoppage is normal, if so resume operation normally. |
| | Motor torque is too low. | If the fault remains, replace the inverter with a model with increased capacity. |
| The motor rotates in the opposite direction to the command. | The wiring for the motor output cable is incorrect. | Determine if the cable on the output side is wired correctly to the phase (U/V/W) of the motor. |
| | The signal connection between the control circuit terminal (forward/reverse rotation) of the inverter and the forward/reverse rotation signal on the control panel side is incorrect. | Check the forward/reverse rotation wiring. |
| The motor only rotates in one direction. | Reverse rotation prevention is selected. | Remove the reverse rotation prevention. |
| | The reverse rotation signal is not provided, even when a 3-wire sequence is selected. | Check the input signal associated with the 3-wire operation and adjust as necessary. |

| Item | Cause | Remedy |
|-----------------------------------------------------------------------|----------------------------------------------------------|---------------------------------------------------------------------------------------------------------------------------------------------------------|
| The motor is overheating. | The load is too heavy. | Reduce the load. Increase Acc/Dec time. |
| | | Check the motor parameters and set the correct values. |
| | | Replace the motor and the inverter with models with appropriate capacity for the load. |
| | The ambient temperature of the motor is too high. | Lower the ambient temperature of the motor. |
| | The phase-to-phase voltage of the motor is insufficient. | Use a motor that can withstand phase-to-phase voltages surges greater than the maximum surge voltage. |
| | | Only use motors suitable for applications with inverters. Connect the AC reactor to the inverter output (set the carrier frequency (Cn04) to 2 kHz). |
| The motor fan has stopped or the fan is obstructed with debris. | Check the motor fan and remove any foreign objects. | |
| The motor stops during acceleration or when connected to load. | The load is too high. | Reduce the load. |
| | | Replace the motor and the inverter with models with appropriate capacity for the load. |
| The motor does not accelerate. /The acceleration time is too long. | The frequency command value is low. | Set an appropriate value. |
| | The load is too high. | Reduce the load and increase the acceleration time. Check the mechanical brake status. |

| Item | Cause | Remedy |
|--------------------------------------------------------------------------------------------|----------------------------------------------------------------------------------------------------|------------------------------------------------------------------------------------------------------------------------------------|
| The motor does not accelerate. /The acceleration time is too long. | The acceleration time is too long. | Change the acceleration time. |
| | The combined values of the motor properties and the inverter parameter are incorrect. | Change the motor related parameters. |
| | The stall prevention level during acceleration is low. | Change the stall prevention level. |
| | The stall prevention level during operation is low. | |
| | Starting torque is insufficient. | If the fault remains, replace the inverter with a model with increased capacity. |
| Motor speed varies during operation. | There is a high variance in load. | Replace the motor and inverter with models that have increased capacity. |
| | The input voltage varies. | Reduce input voltage variation. |
| | Motor speed variations occur at a specific frequency. | Adjust the output frequency to avoid a resonance area. |
| The motor rotation is different from the setting. | The V/F pattern is set incorrectly. | Set a V/F pattern that is suitable for the motor specification. |
| The motor deceleration time is too long even with Dynamic Braking (DB) resistor connected. | The deceleration time is set too long. | Change the setting accordingly. |
| | The motor torque is insufficient. | If motor parameters are normal, it is likely to be a motor capacity fault. Replace the motor with a model with increased capacity. |
| | The load is higher than the internal torque limit determined by the rated current of the inverter. | Replace the inverter with a model with increased capacity. |
| Operation is difficult in underload applications. | The carrier frequency is too high. | Reduce the carrier frequency. |
| | Over-excitation has occurred due to an inaccurate V/F setting at low speed. | Reduce the torque boost value to avoid over-excitation. |

Troubleshooting

| Item | Cause | Remedy |
|----------------------------------------------------------------------------------|----------------------------------------------------------------------------------------------------------|----------------------------------------------------------------------------------------------------------------------------------|
| While the inverter is in operation, a control unit malfunctions or noise occurs. | Noise occurs due to switching inside the inverter. | Change the carrier frequency (Cn04) to the minimum value. |
| | | Install a micro surge filter in the inverter output. |
| When the inverter is operating, the earth leakage breaker is activated. | An earth leakage breaker will interrupt the supply if current flows to ground during inverter operation. | Connect the inverter to a ground terminal. |
| | | Check that the ground resistance is less than 100 Ω for 200 V inverters. |
| | | Check the capacity of the earth leakage breaker and make the appropriate connection, based on the rated current of the inverter. |
| | | Reduce the carrier frequency (Cn04). |
| | | Make the cable length between the inverter and the motor as short as possible. |
| The motor vibrates severely and does not rotate normally. | Phase-to-phase voltage of 3-phase power source is not balanced. | Check the input voltage and balance the voltage. |
| | | Check and test the motor's insulation. |
| The motor makes humming, or loud noises. | Resonance occurs between the motor's natural frequency and the carrier frequency. | Slightly increase or decrease the carrier frequency (Cn04). |
| | Resonance occurs between the motor's natural frequency and the inverter's output frequency. | Slightly increase or decrease the carrier frequency. |
| | | Use the frequency jump function to avoid the frequency band where resonance occurs. (Ad27–33) |

| Item | Cause | Remedy |
|----------------------------------------------------------------------------|-------------------------------------------------------------------------------------------|--------------------------------------------------------------------------------------------------------------------------------------------------------|
| The motor vibrates/hunts. | The frequency input command is an external, analog command. | In situations of noise inflow on the analog input side that results in command interference, change the input filter time constant (In07, In52, In57). |
| | The wiring length between the inverter and the motor is too long. | Ensure that the total cable length between the inverter and the motor is less than 100 m. |
| The motor does not come to a complete stop when the inverter output stops. | It is difficult to decelerate sufficiently, because DC braking is not operating normally. | Adjust the DC braking parameter. |
| | | Increase the set value for the DC braking current. |
| The output frequency does not increase to the frequency reference. | The frequency reference is within the jump frequency range. | Set the frequency reference higher than the jump frequency range. |
| | The frequency reference is exceeding the upper limit of the frequency command. | Set the upper limit of the frequency command higher than the frequency reference. |
| | Because the load is too heavy, the stall prevention function is working. | Replace the inverter with a model with increased capacity. |

11 Maintenance

This chapter explains how to replace the cooling fan, the regular inspections to complete, and how to store and dispose of the product. An inverter is vulnerable to environmental conditions and faults also occur due to component wear and tear. To prevent breakdowns, please follow the maintenance recommendations in this section.

⚠ Caution

- Before you inspect the product, read all safety instructions contained in this manual.
- Before you clean the product, ensure that the power is off.
- Clean the inverter with a dry cloth. Cleaning with wet cloths, water, solvents, or detergents may result in electric shock or damage to the product.

11.1 Regular Inspection Lists

11.1.1 Daily Inspections

| Inspection area | Inspection item | Inspection details | Inspection method | Judgment standard | Inspection equipment |
|-----------------|---------------------|--------------------------------------------------------------------------------------------------------------------|--------------------------------------------------------------------|--------------------------------------------------------------------------------------------|-----------------------------------|
| All | Ambient environment | Is the ambient temperature and humidity within the design range, and is there any dust or foreign objects present? | Refer to <u>1.3 Installation Considerations</u> on page <u>6</u> . | No icing (ambient temperature: -10 - +40) and no condensation (ambient humidity below 50%) | Thermometer, hygrometer, recorder |
| All | Inverter | Is there any abnormal vibration or noise? | Visual inspection | No abnormality | - |
| | Power voltage | Are the input and output voltages normal? | Measure voltages between R/T-phases in. the inverter | Refer to <u>12.1 Input and Output Specification</u> on page <u>235</u> . | Digital multimeter tester |

| Inspection area | Inspection item | Inspection details | Inspection method | Judgment standard | Inspection equipment |
|----------------------|---------------------|-------------------------------------------|-----------------------------------------------------------------------|------------------------------------|--------------------------|
| Input/Output circuit | Smoothing capacitor | Is there any leakage from the inside? | Visual inspection | No abnormality | - |
| | | Is the capacitor swollen? | | | |
| Cooling system | Cooling fan | Is there any abnormal vibration or noise? | Turn off the system and check operation by rotating the fan manually. | Fan rotates smoothly | - |
| Display | Measuring device | Is the display value normal? | Check the display value on the panel. | Check and manage specified values. | Voltmeter, ammeter, etc. |
| Motor | All | Is there any abnormal vibration or noise? | Visual inspection | No abnormality | - |
| | | Is there any abnormal smell? | Check for overheating or damage. | | |

11.1.2 Annual Inspections

| Inspection area | Inspection item | Inspection details | Inspection method | Judgment standard | Inspection equipment |
|----------------------|-----------------|-----------------------------------------------------------------|---------------------------------------------------------------------------------------------------------------------------------|--------------------|----------------------|
| Input/Output circuit | All | Megger test (between input/output terminals and earth terminal) | Disconnect inverter and short R/S/T/U/V/W terminals, and then measure from each terminal to the ground terminal using a Megger. | Must be above 5 MΩ | DC 500 V Megger |
| | | Is there anything loose in the device? | Tighten up all screws. | No abnormality | |
| | | Is there any evidence of parts overheating? | Visual inspection | | |

| Inspection area | Inspection item | Inspection details | Inspection method | Judgment standard | Inspection equipment |
|--------------------------------------|---------------------|------------------------------------------------------------------------------|--------------------------------------------------------------------------------|---------------------------------------------------------------|------------------------------------|
| | Cable connections | Are there any corroded cables? | Visual inspection | No abnormality | - |
| | | Is there any damage to cable insulation? | | | |
| | Terminal block | Is there any damage? | Visual inspection | No abnormality | - |
| | Smoothing capacitor | Measure electrostatic capacity. | Measure with capacity meter. | Rated capacity over 85% | Capacity meter |
| | Relay | Is there any chattering noise during operation? | Visual inspection | No abnormality | - |
| Is there any damage to the contacts? | | Visual inspection | | | |
| Input/output circuit | Braking resistor | Is there any damage from resistance? | Visual inspection | No abnormality | Digital multimeter / analog tester |
| | | Check for disconnection. | Disconnect one side and measure with a tester. | Must be within $\pm 10\%$ of the rated value of the resistor. | |
| Control circuit Protection circuit | Operation check | Check for output voltage imbalance while the inverter is in operation. | Measure voltage between the inverter output terminal U/ V/ W. | Balance the voltage between phases within 4V. | Digital multimeter or DC voltmeter |
| | | Is there an error in the display circuit after the sequence protection test? | Test the inverter output protection in both short and open circuit conditions. | The circuit must work according to the sequence. | |
| Cooling system | Cooling fan | Are any of the fan parts loose? | Check all connected parts and tighten all screws. | No abnormality | - |
| Display | Display device | Is the display value normal? | Check the command value on the display device. | Specified and managed values must | Voltmeter, Ammeter, etc. |

| Inspection area | Inspection item | Inspection details | Inspection method | Judgment standard | Inspection equipment |
|-----------------|-----------------|--------------------|-------------------|-------------------|----------------------|
| | | | | match. | |

11.1.3 Bi-annual Inspections

| Inspection area | Inspection item | Inspection details | Inspection method | Judgment standard | Inspection equipment |
|-----------------|-----------------------|--------------------------------------------------------------|----------------------------------------------------------------|---------------------|----------------------|
| Motor | Insulation resistance | Megger test (between the input, output and earth terminals). | Disconnect the cables for terminals U/V/W and test the wiring. | Must be above 5 MΩ. | DC 500 V Megger |

⚠ Caution

Do not run an insulation resistance test (Megger) on the control circuit as it may result in damage to the product.

11.2 Storage and Disposal

11.2.1 Storage

If you are not using the product for an extended period, store it in the following way:

- Store the product in the same environmental conditions as specified for operation (refer to [1.3 Installation Considerations](#) on page 6).
- When storing the product for a period longer than 3 months, store it between 10°C and 30°C, to prevent depletion of the electrolytic capacitor.
- Do not expose the inverter to snow, rain, fog, or dust.
- Package the inverter in a way that prevents contact with moisture. Keep the moisture level below 70% in the package by including a desiccant, such as silica gel.
- Do not store the inverter in dusty or humid environments. If the inverter is installed in an unsuitable environment (for example, a construction site) and the inverter will be unused for an extended period, remove the inverter and store it in a suitable place.

11.2.2 Disposal

When disposing of the product, categorize it as general industrial waste. Recyclable materials are included in the product, so recycle them whenever possible. The packing materials and all metal parts can be recycled. Although plastic can also be recycled, it can be incinerated under controlled conditions in some regions.

⚠ Caution

If the inverter has not been operated for a long time, capacitors lose their charging characteristics and are depleted. To prevent depletion, turn on the product once a year and allow the device to operate for 30-60 min. Run the device under no-load conditions.

12 Technical Specification

12.1 Input and Output Specification

| Model LSLV□□□□M100-1EOFN□ | | | 0001 | 0002 | 0004 | 0008 | 0015 | 0022 |
|---------------------------|----------------------|----|------------------------------------------|------|-------|------|----------|------|
| Applied motor | Heavy load | HP | 0.125 | 0.25 | 0.5 | 1.0 | 2.0 | 3.0 |
| | | kW | 0.1 | 0.2 | 0.4 | 0.75 | 1.5 | 2.2 |
| Rated output | Rated capacity (kVA) | | 0.3 | 0.6 | 0.95 | 1.9 | 3.0 | 4.5 |
| | Rated current (A) | | 0.8 | 1.4 | 2.4 | 4.2 | 7.5 | 11.0 |
| | Output frequency | | 0-400 Hz | | | | | |
| | Output voltage (V) | | 3-phase 200-240 V | | | | | |
| Rated input | Working voltage (V) | | Single phase 200-240 V AC (-15% to +10%) | | | | | |
| | Input frequency | | 50-60 Hz (±5%) | | | | | |
| | Rated current (A) | | 1.0 | 1.8 | 3.7 | 7.1 | 13.6 | 18.7 |
| Weight (lb/kg) | | | 1.46/0.66 | | 2.2/1 | | 3.2/1.45 | |

- The standard motor capacity is based on a standard 4-pole motor.
- The standard used is based on a 220 V supply voltage
- The rated output current may be limited depending on the carrier frequency (Cn4) setting.
- The maximum output voltage cannot exceed the power voltage. The output voltage can be set below the power voltage.
- The output voltage outputs as below when a motor is not connected to protect the inverter.
 - Carrier frequency 3kHz or less: The output voltage outputs about 17% of the maximum input voltage.
 - Carrier frequency above 3kHz: The output voltage outputs about 15% of the maximum input voltage.

12.2 Product Specification Details

| Item | | Description | |
|-----------|----------------------------------------|--------------------------------------------------------------------------------------------------------------------------------------------------------------------------------------------------------------------------------------------------------------|-----------------------------------------------------------------------------------------------------------------------------------------------------------------------------------------------------------------|
| Control | Control method | V/F control, slip compensation, Simple sensorless | |
| | Frequency settings power resolution | Digital command: 0.01Hz Analog command: 0.06 Hz (60 Hz standard) | |
| | Frequency accuracy | 1% of maximum output frequency | |
| | V/F pattern | Linear, square reduction, user V/F | |
| | Overload capacity | Rated current: 150% 1 min | |
| | Torque boost | Manual torque boost, automatic torque boost | |
| Operation | Operation type | Select key pad, terminal strip, or communication operation | |
| | Frequency settings | Analog type: V1terminal 0–10 V, I2 terminal (Advanced I/O) 0–20 mA and 0–10 V Digital type: key pad input | |
| | Operation function | <ul style="list-style-type: none"> • Anti-forward and reverse direction rotation • Frequency jump • Frequency limit • DC braking • Jog operation • Up-down operation • 3-wire operation | <ul style="list-style-type: none"> • Dwell operation • Slip compensation • PID control • Energy saving operation • Speed search • Automatic restart |
| | Input | Multi-function terminal | Select PNP (Source) or NPN (Sink) mode. The function can be set depending on the parameter settings at In65–69 (advanced I/O) or In65–67 (standard I/O) codes. |

| Item | | Description | | |
|---------------------|------------------------|------------------------------------------------------------|---------------------------------------------------------------------------------------------------------------------------------------------------------------------------------------------------------------------------------------------------------------------------------------------------------------------------------------------------------|-------------------------------------------------------------------------------------------------------------------------------------------------------------------------------------------------------------------------------------------------------------------------------------------------------------------------------------------|
| Operation | Input | Multi-function terminal | <ul style="list-style-type: none"> • Forward direction operation • Reset • Emergency stop • Multi-step speed frequency-high/med/low • DC braking during stop • Frequency increase • 3-wire • Select acc/dec/stop | <ul style="list-style-type: none"> • Reverse direction operation • External trip • Jog operation • Multi-step acc/dec-high/med/low • Second motor selection • Frequency reduction • Fix analog command frequency • Transition from PID to general operation |
| | Output | Multi-function open collector terminal (standard I/O only) | Fault output and inverter operation status output | Less than DC 24 V, 50 mA |
| | | Multi-function relay terminal | | Less than (N.O., N.C.) AC250V 1A, Less than DC 30V, 1A |
| | | Analog output | | 0–10 Vdc: Select frequency, output current, output voltage, DC terminal voltage and others |
| Protection function | Trip | | <ul style="list-style-type: none"> • Motor over heat trip • Motor overload trip • Output open-phase trip • External signal trip • Inverter overload trip • Command loss trip • Over current trip • Inverter over heat • Over voltage trip • Ground trip | <ul style="list-style-type: none"> • COM trip • Fan trip • Low voltage trip • Command loss trip |
| | Alarm | | Overload alarm | |
| | Instantaneous blackout | | Less than 15 ms: continue operation (must be within the rated input voltage and rated output range) More than 15 ms: auto restart operation | |

| Item | Description | |
|--------------------------------------|-----------------------------------|-----------------------------------------------------------------------------------------------------------------------|
| Structure/ working environment | Cooling type | Natural cooling structure (0.1–0.2 kW) Forced fan cooling structure (0.4–2.2 kW) |
| | Protection structure | IP 20, UL Open Type |
| | Ambient temperature ¹⁾ | -10–50°C (14–122°F) (No ice or frost should be present.) |
| | Ambient humidity | Relative humidity less than 95% RH (to avoid condensation forming) |
| | Storage temperature | -20°C–65°C (-4–149°F) |
| | Surrounding environment | Prevent contact with corrosive gases, inflammable gases, oil stains, dust, and other pollutants (Pollution Degree 2). |
| | Operation altitude/oscillation | No higher than 3280ft (1,000 m). Less than 9.8 m/sec ² (1G). |
| | Pressure | 70–106 kPa |

1) The 0.1 kW–0.2 kW products can be operated at a maximum of 50°C. However, the lifespan of the product may be reduced when operating continuously with a full load when the ambient temperature exceeds 40°C (35°C when an optional vent cover is installed).

12.3 External Dimensions (IP 20 Type)

0.1-0.2 kW (Single Phase)

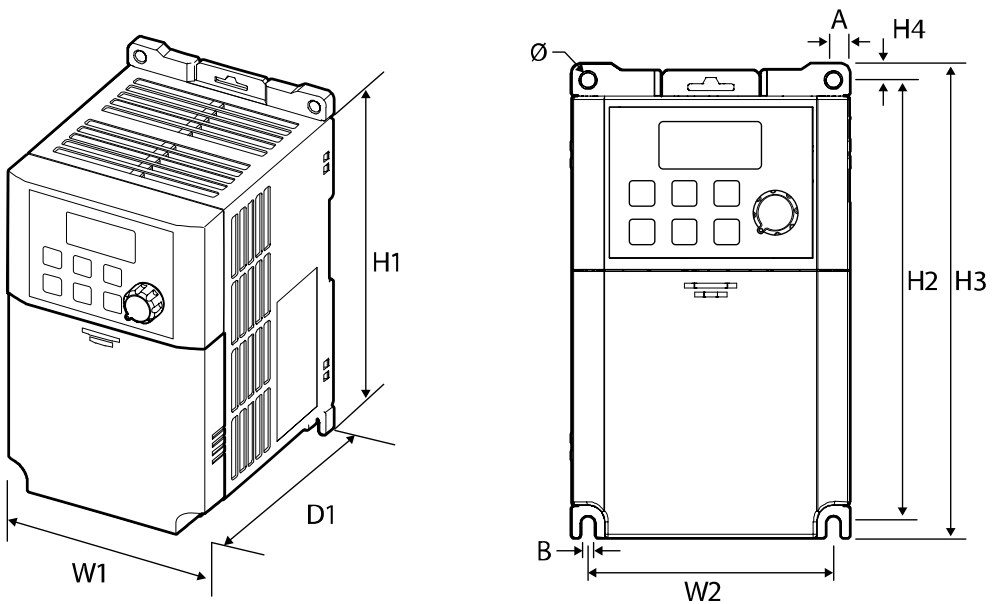

0.4-0.8 kW (Single Phase)

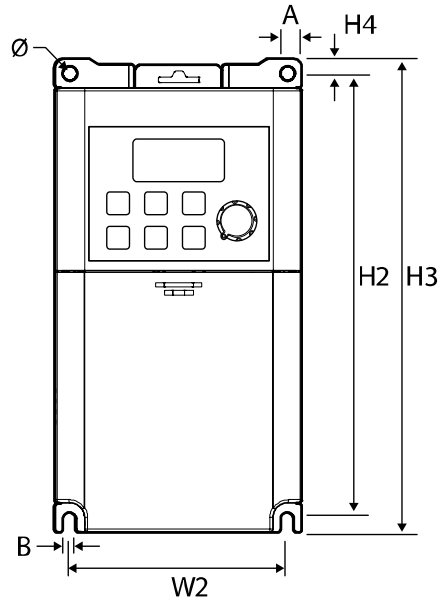
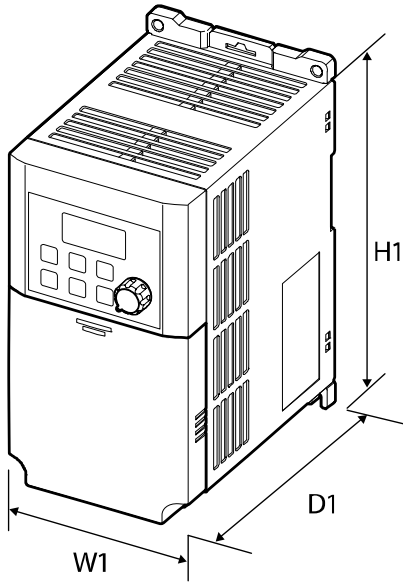

1.5-2.2 kW (Single Phase)

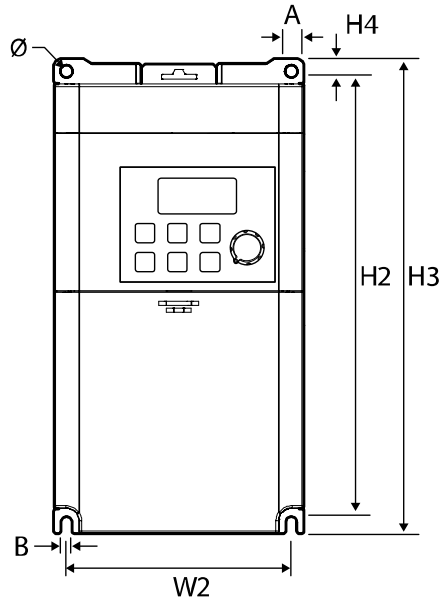
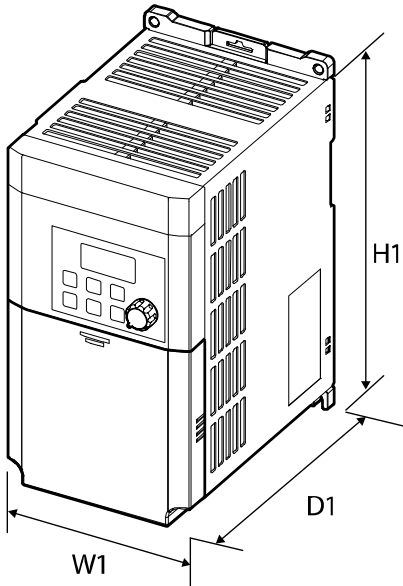

| Items | W1 | W2 | H1 | H2 | H3 | H4 | D1 | A | B | Φ |
|----------------------------|---------------|--------------|---------------|-----------------|---------------|-------------|---------------|-------------|---------------|---------------|
| 0001M100-1, 0002M100-1 | 85 (3.34) | 75 (2.95) | 135 (5.31) | 135.5 (5.33) | 145 (5.70) | 5 (0.19) | 100 (3.93) | 5 (0.19) | 4.5 (0.18) | 4.5 (0.18) |
| 0004M100-1, 0008M100-1 | 85 (3.34) | 75 (2.95) | 153 (6.02) | 153.5 (6.04) | 163 (6.42) | 5 (0.19) | 123 (4.84) | 5 (0.19) | 4.5 (0.18) | 4.5 (0.18) |
| 0015M100-1, 0022M100-1, | 100 (3.94) | 90 (3.54) | 180 (7.08) | 180.5 (7.10) | 190 (7.48) | 5 (0.19) | 140 (5.51) | 5 (0.19) | 4.5 (0.18) | 4.5 (0.18) |

Unit: mm (inches)

12.4 Peripheral Devices

Compatible (Circuit Breaker, Leakage Breaker), Magnetic Contactor) and Motor Circuit Breaker (MMS) Models (manufactured by LS ELECTRIC)

| Inverter Capacity | Circuit Breaker | | Leakage Breaker | | Magnetic Contactor | | Motor Circuit Breaker (MMS) | |
|-------------------|-----------------|------------|-----------------|------------|--------------------|------------|-----------------------------|------------|
| | Model | Rating [A] | Model | Rating [A] | Model | Rating [A] | Model | Rating [A] |
| 0.1kW-1 | UTE100 N | 15 | EBS33c | 5 | MC-6a | 9 | MMS-32H-1 | 1 |
| 0.2kW-1 | | | | | | | MMS-32H-2.5 | 2.5 |
| 0.4kW-1 | | | | MMS-32H-6 | | | 6 | |
| 0.8kW-1 | | | | MMS-32H-8 | | | 8 | |
| 1.5kW-1 | | 20 | | 15 | MC-18a, MC18b | 18 | MMS-32H-17 | 17 |
| 2.2kW-1 | | | | 220 | GMC-32 | 22 | MMS-32H-32 | 32 |

12.5 Fuse and Reactor Specifications

| Inverter capacity | AC Input Fuse | | AC Reactor | |
|-------------------|---------------|------------|-----------------|-------------|
| | Current [A] | Voltage[V] | Inductance [mH] | Current [A] |
| 0.1kW-1 | 5 | 600 | 4.2 | 3.5 |
| 0.2kW-1 | | | | |

| Inverter capacity | AC Input Fuse | | AC Reactor | |
|-------------------|---------------|--|------------|----|
| 0.4kW-1 | 10 | | 1.2 | 10 |
| 0.8kW-1 | | | | |
| 1.5kW-1 | 15 | | 0.88 | 14 |
| 2.2kW-1 | 20 | | 0.56 | 20 |

⚠ Caution

Only use Class H or RK5, UL listed input fuses and UL listed circuit breakers. See the table above for the voltage and current ratings for fuses and circuit breakers.

⚠ Attention

Utiliser UNIQUEMENT des fusibles d'entrée homologués de Classe H ou RK5 UL et des disjoncteurs UL. Se reporter au tableau ci-dessus pour la tension et le courant nominal des fusibles et des disjoncteurs.

12.6 Terminal Screw Specification

Input/Output Terminal Screw Specification

| Product (kW) | | Terminal Screw Size | | | | | | | Screw Torque (Kgf-cm/Nm) |
|----------------------|------|---------------------|------|---|----|----|---|-----------------------|----------------------------|
| | | E | R | T | B1 | B2 | U | V | |
| Single phase 200V | 0.1 | M3 | | | | | | | M3-M3.5 2.1-5.0/0.2-0.5 |
| | 0.2 | | | | | | | | |
| | 0.4 | | | | | | | | |
| | 0.75 | | | | | | | | |
| | 1.5 | M4 | M3.5 | | | | | M4 2.1-8.0/0.2-0.8 | |
| | 2.2 | | | | | | | | |

Control Circuit Terminal Screw Specification

| Terminal | Terminal Screw Size | Screw Torque (Kgf-cm/Nm) |
|--------------------------------------------------------------------------------|---------------------|--------------------------|
| P1- P5/CM/VR/1/I2/AO/Q1/EG/24 ¹⁾ A1/B1/C1/A2/C2 ¹⁾ | M2.6 | 4.0/0.4 |

1) P4, P5, I2, A2, and C2 terminals are unavailable when using the standard I/O. Q1 and EG terminals are unavailable when using the advanced I/O.

Refer to [2.2 Cable Wiring Step 4 Control Terminal Wiring](#) on page [24](#).

ⓘ Caution

Apply rated torques to the terminal screws. Loose screws may cause short circuits and malfunctions. Tightening the screw too much may damage the terminals and cause short circuits and malfunctions. Use copper wires only with 600V, 75 °C rating for the power terminal wiring, and 300V, 75 °C rating for the control terminal wiring.

ⓘ Attention

Appliquer des couples de marche aux vis des bornes. Des vis desserrées peuvent provoquer des courts-circuits et des dysfonctionnements. Ne pas trop serrer la vis, car cela risque d'endommager les bornes et de provoquer des courts-circuits et des dysfonctionnements. Utiliser uniquement des fils de cuivre avec une valeur nominale de 600 V, 75 °C pour le câblage de la borne d'alimentation, et une valeur nominale de 300 V, 75 °C pour le câblage de la borne de commande.

12.7 Braking Resistor Specification

| Product (kW) | Resistance (Ω) | Rated Capacity (W) |
|--------------|-------------------------|--------------------|
| 1.5 | 60 | 300 |
| 2.2 | 50 | 400 |

The standard for braking torque is 150% and the working rate (%ED) is 5%. If the working rate is 10%, the rated capacity for braking resistance must be calculated at twice the standard.

12.8 Continuous Rated Current Derating

Derating by Carrier Frequency

The continuous rated current of the inverter is limited based on the carrier frequency. Refer to the following graph.

| Frame A (0.1kW-1, 0.2kW-1) | | Frame B/C (0.4kW-1–2.2kW-1) | |
|----------------------------|----------------------------|-----------------------------|----------------------------|
| Carrier Frequency (kHz) | Constant-rated Current (%) | Carrier Frequency (kHz) | Constant-rated Current (%) |
| 1–4 | 100 | 1–6 | 100 |
| 8 | 88 | 8 | 88 |
| 12 | 77 | 12 | 77 |
| 15 | 72 | 15 | 72 |

[Frame A (0.1kW-1, 0.2kW-1)]

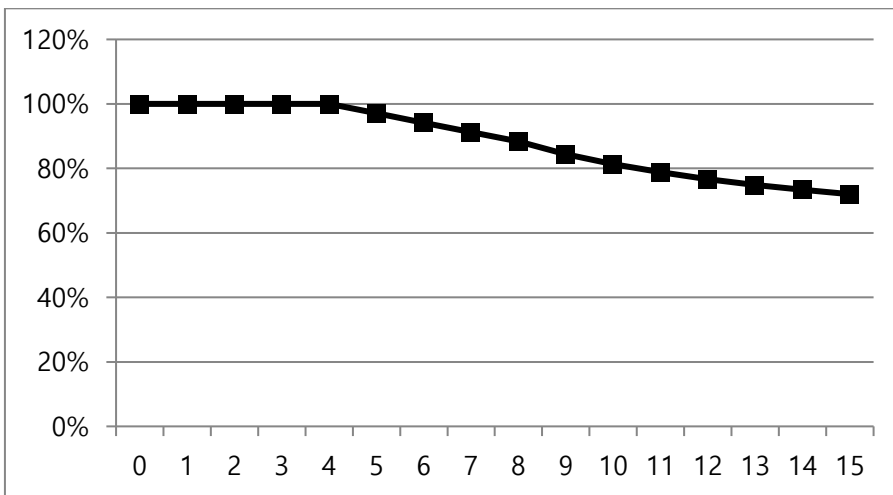

The 0.1 kW–0.2 kW products can be operated at a maximum of 50 °C. However, the lifespan of the product may be reduced when operating continuously with a full load when the ambient temperature exceeds 40 °C (35 °C when an optional vent cover is installed).

[Frame B/C (0.4kW-1–2.2kW-1)]

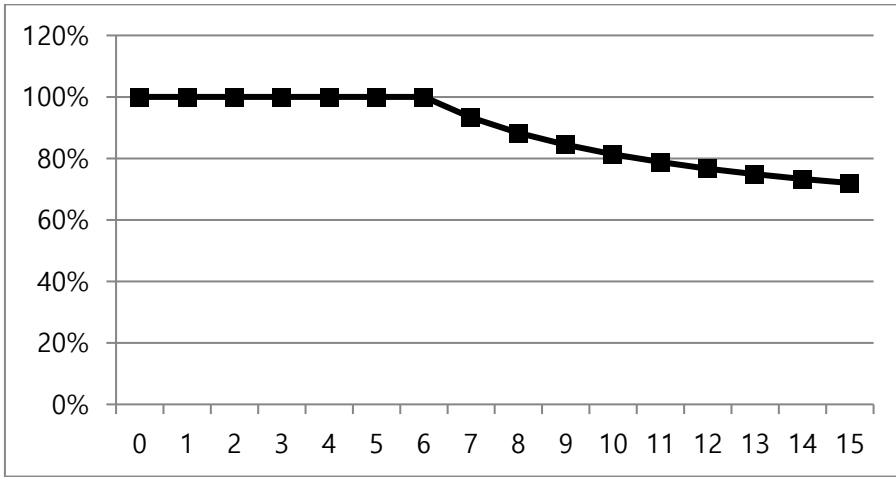

If the ambient temperature is high, and if the maximum carrier frequency for continuous full load conditions (4 kHz for A Frame 0.1 kW-1/0.2 kW-1 products, 6 kHz for B/C Frame 0.4 kW-1 – 2.2 kW-1 products) is exceeded, a protective feature may be activated to limit the carrier frequency (to 4 kHz / 6 kHz) to prevent damages to the product.

The protective feature will be deactivated and the user-configured carrier frequency will be used again when the internal temperature becomes low enough for reliable operation.

Before operating the product with a high carrier frequency, refer to the table above to ensure that the carrier frequency is appropriately set for reliable operation at continuous full load conditions(%).

Derating by Input Voltage

The continuous rated current of the inverter is limited based on the input voltage. Refer to the following graph.

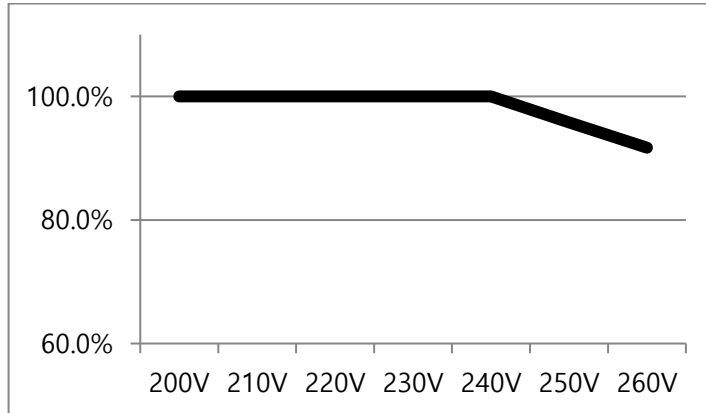

| Input voltage | 200V | 210V | 220V | 230V | 240V | 250V | 264V |
|------------------------|--------|--------|--------|--------|--------|-------|-------|
| Constant-rated current | 100.0% | 100.0% | 100.0% | 100.0% | 100.0% | 95.8% | 90.0% |

Derating by Ambient Temperature and Installation Type

The constant-rated current of the inverter is limited based on the ambient temperature and installation type. Refer to the following graph.

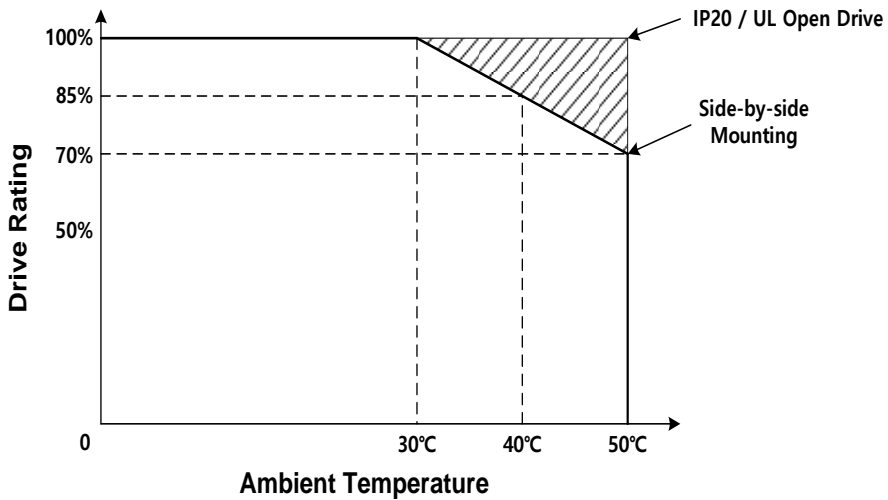

12.9 Remote Keypad Option

The option consists of a remote keypad and cables (1M, 2M, 3M, 5M).

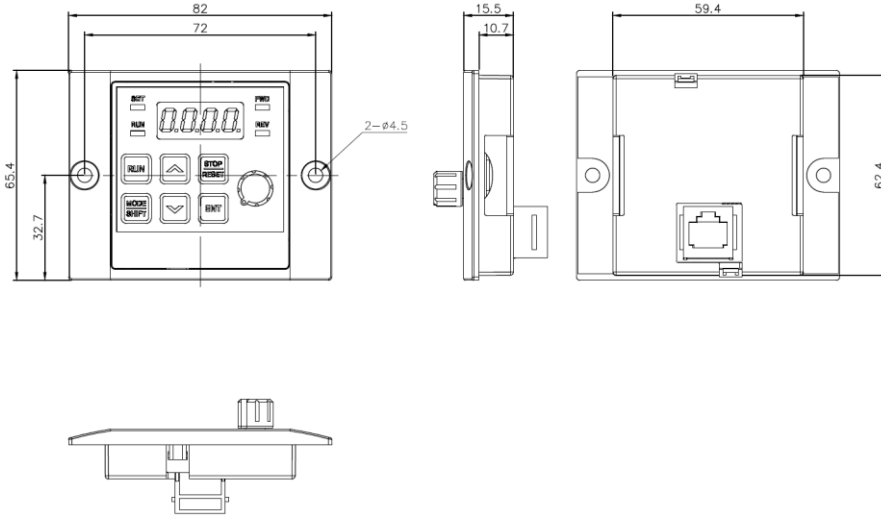

Unit: mm

Installation

- 1 Remove the remote keypad cable connection hole and then connect the cable of the remote keypad to the I/O RJ45 connector.
- 2 Connect the other end of the cable to the remote keypad.

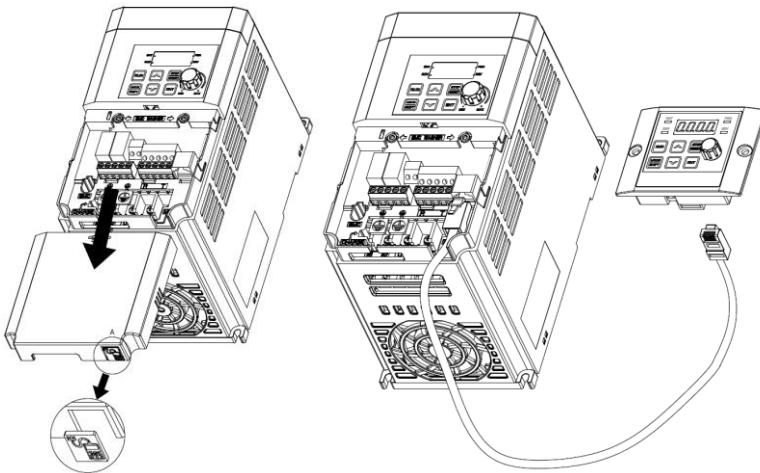

How to use

- 1 When connecting the remote keypad, the key and potentiometer on the inverter keypad are ignored and replaced by the key and potentiometer on the remote keypad.
 - Dismount the remote keypad and 2 seconds later, it will return to the original position with the key and potentiometer on the inverter keypad.

(If the frequency reference source set to potentiometer, at the time of mounting and dismounting, the command frequency is instantly switched between the inverter keypad potentiometer and the remote keypad potentiometer. Be careful that the motor does not rotate at an unintended frequency.)

 - If communication between the inverter and the remote keypad is not established, "E.vEr" is displayed on the remote keypad 7-Seg.
- 2 With the remote keypad connected to the inverter, parameter settings saved in the inverter can be copied to the remote keypad by setting the dr 85 to 1.
 - "R-UL" is displayed on the 7-Seg keypad during upload. When the save is complete, the text disappears and the main screen is displayed.
 - If there is an error such as communication error during upload, "FAIL" warning message will be displayed for 3 seconds and the operation to save the parameter on the remote keypad will fail.
- 3 With the remote keypad connected to the other inverter of same series, parameter settings saved in the remote keypad can be copied to the inverter by setting the dr 86 to 1.
 - "W-dL" is displayed on the 7-Seg keypad during saving. When the save is complete, the text disappears and the main screen is displayed.
 - At this time, if the model name of the inverter is wrong or the version of the parameter code of the inverter is wrong or if an error such as remote keypad communication error occurs, a warning message "FAIL" is displayed for 3 seconds and the parameter is set to inverter Will fail.

Product Warranty

Warranty Period

The warranty period is 24 months from the date of manufacture.

Scope of Warranty

1. The initial diagnosis of faults should be conducted by the user. However, upon request, LS ELECTRIC or its representative(s) can undertake this task for a fee. If the cause of the fault is found to be the responsibility of LS ELECTRIC, this service will be free of charge.
2. This warranty only applies if the product is used under normal conditions according to the specifications and precautions described in the handling instructions, user manuals, catalogs, and caution labels.
3. During the warranty period, repairs shall be charged for the following cases:
 - (1) Replacement of consumable and life-limited parts (e.g. relays, fuses, electrolytic capacitors, batteries, fan, etc.)
 - (2) Failures or damage caused by improper storage, handling, negligence, or accidents by the user
 - (3) Failures resulting from the user's hardware or software design
 - (4) Failures caused by modifications made without LS ELECTRIC's consent (If modifications or repairs are not conducted by LS ELECTRIC or its representative(s), further repairs including paid services will be refused)
 - (5) Failures that could have been avoided if the user's equipment, in which the product is incorporated, had safety devices required by legal regulations or common industry standards
 - (6) Failures that could have been prevented if maintenance and replacement of consumable parts were performed normally according to the handling instructions or user manuals
 - (7) Failures and damage to the product caused due to the connected equipment or use of inappropriate consumables
 - (8) Failures caused by external factors such as fire, abnormal voltage, force majeure, and natural disasters such as earthquakes, lightning, salt damage, wind, flood damage, etc.
 - (9) Failures that cannot be predicted/solved by current scientific technology at the time of manufacture
 - (10) Other failures, damage, or defects recognized as the responsibility of the user.

Manual Revision History

Revision History

| No | Date | Edition | Changes |
|----|---------|---------|------------------------|
| 1 | 2018.04 | V1.0 | - |
| 2 | 2020.01 | V1.1 | S/W Version up : V1.50 |
| 3 | 2020.05 | V1.2 | S/W Version up : V1.60 |
| 4 | 2022.09 | V2.0 | S/W Version up: V1.70 |
| | | | |
| | | | |
| | | | |

EC DECLARATION OF CONFORMITY

We, the undersigned,

Representative: **LS ELECTRIC Co., Ltd.**
Address: **LS Tower, 127, LS-ro, Dongan-gu,
Anyang-si, Gyeonggi-do, Korea**

Manufacturer: **LS ELECTRIC Co., Ltd.**
Address: **56, Samseong 4-gil, Mokcheon-eup,
Dongnam-gu, Cheonan-si,
Chungcheongnam-do, Korea**

Certify and declare under our sole responsibility that the following apparatus:

Type of Equipment: **Inverter (Power Conversion Equipment)**
Model Name: **LSLV-M100 series**
Trade Mark: **LS ELECTRIC Co.,Ltd.**

This declaration of conformity is under the sole responsibility of the manufacturer.

Conforms to the essential requirements of the directives:

2014/30/EU Directive of the European Parliament and of the Council on the harmonization of the laws of the Member States relating to electromagnetic compatibility.

2014/35/EU Directive of the European Parliament and of the Council on the harmonization of the laws of the Member States relating to the making available on the market of electrical equipment designed for use within certain voltage limits.

2011/65/EU Directive on the restriction of the use certain of certain Hazardous Substances in electrical and electronic equipment –RoHs.-

Based on the following specifications applied:

EN IEC 61800-3:2018
EN 61800-5-1:2007+A1:2017+ A11:2021
EN IEC 63000:2018

and therefore, complies with the essential requirements and provisions of the 2014/30/EU, 2014/35/EU and 2011/65/EU Directives.

Place: **Cheonan, Chungnam,
Korea**

박창근 2022. 8. 16 (Signature/Date)

Mr. PARK CHANGKEUN / Manager

UL mark



The UL mark applies to products in the United States and Canada. This mark indicates that UL has tested and evaluated the products and determined that the products satisfy the UL standards for product safety. If a product received UL certification, this means that all components inside the product had been certified for UL standards as well.

CE mark



The CE mark indicates that the products carrying this mark comply with European safety and environmental regulations. European standards include the Machinery Directive for machine manufacturers, the Low Voltage Directive for electronics manufacturers and the EMC guidelines for safe noise control.

Low Voltage Directive

We have confirmed that our products comply with the Low Voltage Directive (EN 61800-5-1).

EMC Directive

The Directive defines the requirements for immunity and emissions of electrical equipment used within the European Union. The EMC product standard (EN 61800-3) covers requirements stated for drives.

Index

2
24 terminal28

3
3-Wire Operation 116

4
4-pole standard motor235

7
7-segment display40
 letters40
 numbers40

A

A1/C1/B1 terminal28
Acc/Dec pattern91
 linear pattern91
Acc/Dec stop94
Acc/Dec time
 configuration via multi-function terminal 88
 maximum frequency86
 operation frequency87
analog input42
analog output42
 AO terminal28
analog output28
Analog Output142
AO terminal28
ASCII code182
asynchronous communications system..171
auto restart settings129
auto torque boost100

B

basic operation39
brake23
braking resistor23
 braking resistor specification242
 braking torque242
broadcast178

C

cable11
 selection11
Cable
 Ground Specifications11
 Power I/O Cable Specifications11
carrier frequency
 derating243
charge indicator217, 222
cleaning229
CM terminal27
Command source
 RS-48583
common terminal Refer to *EG terminal*
communication171
 command loss protective operation175
 communication address183
 communication line connection173
 communication parameters173
 communication speed174
 communication standards171
 illustration of the system configuration 172
 PLC171
 protocol176
compatible common area parameter186
config mode(CNF)157
Considerations for the installation
 Air Pressure6
 Altitude/Vibration6
 Ambient Humidity6

| | |
|-------------------------------------|-----|
| Environmental Factors | 6 |
| Considerations for the installation | |
| Ambient Temperature | 6 |
| customer service center | 217 |

D

| | |
|-----------------------------|----------|
| DC braking after stop | 101, 107 |
| DC braking frequency | 107 |
| derating | 243, 246 |
| disposal | 229, 233 |
| Dwell Operation | 117 |

E

| | |
|-----------------------------|-----|
| earth leakage breaker | 226 |
| EG terminal | 28 |

EMC filter

| | |
|------------------------------------|-------------|
| asymmetric power | 32 |
| Enclosed Type 1 | 238 |
| energy saving operation | 126 |
| error code | 181 |
| FE(frame error) | 181 |
| IA(illegal data address) | 181 |
| ID(illegal data value) | 181 |
| IF(illegal function) | 181 |
| WM(write mode error) | 181 |
| ESC key | 41 |
| external 24 V power terminal | Refer to 24 |
| <i>terminal</i> | |

F

| | |
|------------------------------------|----------|
| factory default | 54 |
| fatal | 217 |
| fault | |
| fatal | 217 |
| latch | 217 |
| level | 217 |
| trip | 218 |
| fault signal output terminal | Refer to |
| <i>A1/C1/B1 terminal</i> | |
| FE(frame error) | 181 |
| free run stop | 102 |

| | |
|----------------------------------------|----------|
| frequency jump | 104 |
| frequency limit | 103, 106 |
| frequency jump | 104 |
| frequency upper and lower limit value | 103 |
| maximum/start frequency | 103 |
| frequency setting | |
| keypad | 68 |
| variable resistor | 54 |
| frequency setting(voltage) terminal .. | Refer to |
| <i>V1 terminal</i> | |
| fuse | 241 |

G

| | |
|-----------------------------------|-----|
| ground | 20 |
| ground terminal | 20 |
| Ground | |
| Ground Cable Specifications | 11 |
| Ground Trip | |
| ground fault trip | 218 |

H

| | |
|--------------------------|-----|
| half duplex system | 171 |
|--------------------------|-----|

I

| | |
|-------------------------------------------|-----|
| I2 | |
| frequency setting(current/voltage) | |
| terminal | 27 |
| I2 terminal | 27 |
| I2 terminal | |
| analog input selection switch (SW2) | 27 |
| IA(illegal data address) | 181 |
| ID(illegal data value) | 181 |
| IF(illegal function) | 181 |
| Input and Output Specification | 235 |
| input terminal | 27 |
| CM terminal | 27 |
| I2 terminal | 27 |
| P1-P7 terminal | 27 |
| V1 terminal | 27 |
| VR terminal | 27 |
| inspection | |

| | |
|--------------------------------------------|-----|
| annual inspection..... | 230 |
| bi-annual inspection..... | 232 |
| daily inspections..... | 229 |
| installation | |
| wiring..... | 18 |
| installation considerations..... | 6 |
| Installation considerations..... | 6 |
| inverse time-limit thermal characteristics | 218 |
| IP 20..... | 238 |

J

| | |
|---------------------|-----|
| Jog Operation..... | 110 |
| FWD Jog..... | 110 |
| jump frequency..... | 105 |

K

| | |
|-----------------------|----|
| keypad..... | 39 |
| display..... | 39 |
| keypad display..... | 40 |
| keypad key | |
| [ESC] key..... | 41 |
| [RUN] key..... | 41 |
| [STOP/RESET] key..... | 41 |

L

| | |
|-------------------------------------|--------------|
| latch..... | 217 |
| LCD loader config mode (CNF)..... | 157 |
| leakage breaker..... | 240 |
| level..... | 217 |
| lift-type load..... | 98, 117, 118 |
| linear pattern..... | 91 |
| locating the installation site..... | 7 |
| location..... | 7 |
| LS INV 485 protocol..... | 176 |

M

| | |
|--------------------------|---------|
| magnetic contactor..... | 24, 240 |
| maintenance..... | 229 |
| manual torque boost..... | 98 |

| | |
|--------------------------------------------|----------|
| Master..... | 172 |
| megger test..... | 230, 232 |
| Modbus-RTU protocol..... | 183 |
| monitor | |
| monitor registration protocol details..... | 180 |
| Operation State Monitor..... | 151 |
| motor output voltage adjustment..... | 97 |
| motor rotational direction..... | 37 |
| multi-drop Link System..... | 171 |
| multi-function key..... | 40 |
| multi-function terminal..... | 27 |

N

| | |
|----------------------|----|
| NPN mode (Sink)..... | 31 |
|----------------------|----|

O

| | |
|-------------------------------|-----|
| operation noise..... | 130 |
| frequency jump..... | 104 |
| output/communication | |
| 24 terminal..... | 28 |
| EG terminal..... | 28 |
| S+/S- terminal..... | 28 |
| output/communication terminal | |
| A1/C1/B1 terminal..... | 28 |
| AO terminal..... | 28 |
| Q1 terminal..... | 28 |

P

| | |
|--------------------------------|--------------------------------------|
| P1~P7..... | <i>multi-function input terminal</i> |
| parameter..... | 48 |
| initialization..... | 136 |
| parameter setting..... | 48 |
| part names..... | 3 |
| parts illustrated..... | 3 |
| peripheral devices..... | 240 |
| phase-to-phase voltage..... | 224 |
| PID control..... | 121 |
| configuration..... | 121 |
| integral time(PID I-Time)..... | 123 |
| PLC..... | 171 |

| | |
|-------------------------------------|-----|
| PNP mode (Source)..... | 31 |
| PNP/NPN mode selection switch (SW1) | |
| PNP mode (Source)..... | 31 |
| PNP/NPN mode selection switch(SW1) | |
| NPN mode (Sink)..... | 31 |
| power terminal | |
| P2+/B terminal..... | 23 |
| U/V/W terminals..... | 23 |
| power terminals | |
| R/T terminals..... | 23 |
| protocol..... | 176 |
| LS INV 485 protocol..... | 176 |
| Modbus-RTU protocol..... | 183 |

Q

| | |
|------------------|----|
| Q1 terminal..... | 28 |
|------------------|----|

R

| | |
|------------------------------------------------------------------------------|----------|
| R/S/T terminals..... | 222 |
| R/T terminals..... | 23 |
| rated | |
| braking resistance rated capacity..... | 242 |
| derating..... | 243, 246 |
| rating..... | 235 |
| rated input..... | 235 |
| rated output..... | 235 |
| rated slip frequency..... | 120 |
| refer to Modbus-RTU ProtocolModbus-RTU Protocol | |
| resonance frequency | |
| carrier frequency..... | 130 |
| RS-232..... | 172 |
| communication..... | 172 |
| converter..... | 172 |
| RS-485 | |
| communication..... | 172 |
| converter..... | 172 |
| signal terminal..... | 28 |
| RS-485 signal input terminal..Refer to S+/S-terminal, Refer to S+/S-terminal | |

S

| | |
|------------------------------------------------------------------------------------------------------------------|----------|
| S+/S- terminal..... | 28 |
| safety information..... | ii |
| screw specification..... | 241 |
| control circuit terminal screw..... | 241 |
| input/output terminal screw..... | 241 |
| screw size..... | 241 |
| screw torque..... | 241 |
| sequence common terminal..... Refer to <i>CM terminal</i> | |
| serge killer..... | 34 |
| side by side..... | 245, 247 |
| Slave..... | 172 |
| slip compensation operation..... | 119 |
| Square reduction | |
| V/F pattern Operation..... | 96 |
| stop mode..... | 101 |
| DC braking after stop..... | 101, 107 |
| deceleration stop..... | 101 |
| free run stop..... | 102 |
| storage..... | 232 |
| Storing Temperature..... | 6 |
| surge killer..... | 24 |
| SW1..... Refer to <i>PNP/NPN mode selection switch(SW1)</i> , Refer to <i>PNP/NPN mode selection switch(SW1)</i> | |
| SW2...Refer to <i>input selection switch (SW2)</i> | |
| SW3..... Refer to <i>analog output selection switch(SW3)</i> | |
| switch..... | 25 |

T

| | |
|------------------------------------------|----------|
| technical specification | |
| specification details..... | 236 |
| terminal for frequency reference setting | |
| Refer to <i>VR terminal</i> | |
| torque boost..... | 98 |
| auto torque boost..... | 100 |
| manual torque boost..... | 98 |
| overexcitation..... | 99 |
| trip..... | 156, 217 |
| fault trips..... | 218 |

| | |
|-----------------------------------|-----|
| trip condition monitor | 59 |
| troubleshooting fault trips | 220 |
| troubleshooting | |
| other faults | 222 |
| troubleshooting fault trips | 220 |

U

| | |
|----------------------------------------|---------|
| U/V/W terminals | 23, 222 |
| Unipolar (unipolar power source) | 27 |
| update | 180 |
| Up-Down Operation | 112 |
| user V/F pattern operation | 96 |
| using the keypad | 43 |
| using the using the keypad | |
| parameter setting | 48 |

V

| | |
|------------------------------------------|----|
| V/F control | 95 |
| Square reduction V/F pattern Operation | 96 |
| user V/F pattern operation | 96 |
| V1 terminal | 27 |
| V2 input | |
| analog input selection switch(SW2) | 27 |
| variable resistor | 54 |
| variable torque load | 96 |
| VR terminal | 27 |

W

| | |
|----------------------------|-----|
| warning | 217 |
| wiring | 18 |
| circuit breaker | 240 |
| ground | 20 |
| WM(write mode error) | 181 |

