

AX series

INSTRUCTION MANUAL

HANYOUNGNUX CO.,LTD
28, Gilpa-ro 71beon-gil,
Michuhol-gu, Incheon, Korea
TEL : +82-32-876-4697
http://www.hanyoungnux.com

Thank you for purchasing Hanyoung Nux products. Please read the instruction manual carefully before using this product, and use the product correctly. Also, please keep this instruction manual where you can view it any time.

MA0613KE210226

Safety information

Please read the safety information carefully before the use, and use the product correctly. The alerts declared in the manual are classified into **Danger**, **Warning** and **Caution** according to their importance

DANGER	Indicates an imminently hazardous situation which, if not avoided, will result in death or serious injury
WARNING	Indicates a potentially hazardous situation which, if not avoided, could result in death or serious injury
CAUTION	Indicates a potentially hazardous situation which, if not avoided, may result in minor injury or properties damage

DANGER

- The input/output terminals are subject to electric shock risk. Never let the input/output terminals come in contact with your body or conductive substances.

WARNING

- When used in equipment with a high risk of personal injury or properties damage (examples: medical devices, nuclear control, ships, aircrafts, vehicles, railways, combustion devices, safety devices, crime/disaster prevention equipment etc.) install double safety devices and prevent accidents. Failure to do so may result in fire, personnel accident or properties damage.
- Since this product is not equipped with a power switch and fuse, install them separately on the outside (fuse rating: 250 V a.c., 0.5 A).
- Please supply the rated power voltage, in order to prevent product breakdowns or malfunctions.
- To prevent electric shocks and malfunctions, do not supply power until the wiring is completed.
- The product does not have an explosion-proof structure, so avoid using it in places with flammable or explosive gases.
- Never disassemble, modify, process, improve or repair this product, as it may cause abnormal operations, electric shocks or fires.
- Please disassemble the product after turning OFF the power. Failure to do so may result in electric shocks, product abnormal operations or malfunctions.
- Any use of the product other than those specified by the manufacturer may result in personal injury or properties damage.
- Please use this product after installing it to a panel, because there is a risk of electric shock.

CAUTION

- The contents of this manual may be changed without prior notification. Please make sure that the product specifications are the same as you ordered.
- Please make sure that there are no damages or product abnormalities occurred during shipment.
- Use the product in a temperature range from -5 to 50 °C (max. 40 °C for close installation) / 35 to 85% RH (without condensation)
- Please use the product in places where corrosive gases (especially harmful gases, ammonia, etc.) and flammable gases are not generated.
- Use the product in places where vibrations and impacts are not applied directly to product body.
- Please use the product in places without liquids, oils, chemicals, steam, dust, salt, iron, etc. (pollution degree 1 or 2).
- Please do not wipe the product with organic solvents such as alcohol, benzene, etc. (wipe it with neutral detergents).
- Please avoid places where large inductive interference, static electricity, magnetic noise are generated.
- The display characters may not be visible in external sunlight or heavily illuminated indoor environments.
- Please avoid places with heat accumulation caused by direct sunlight, radiant heat, etc.
- Please use the product in places with elevation below 2000 m.

CAUTION

- When water enters, short circuit or fire may occur, so please inspect the product carefully.
- For thermocouple input, use the predetermined compensating cable (temperature errors occur when using ordinary cable).
- For RTD input, use a cable with small lead wire resistance and without resistance difference among 3 wires (temperature errors occur if the resistance value among 3 wires is different).
- Use the input signal line away from power line and load line to avoid the influence of inductive noise.
- Input signal line and output signal line should be separated from each other. If separation is not possible, use shield wires for input signal line.
- Use a non-grounded sensor for thermocouple using a grounded sensor may cause malfunctions to the device due to short circuits).
- When there is a lot of noise from the power, we recommend to use insulation transformer and noise filter. Please install the noise filter to a grounded panel or structure, etc. and make the wiring of noise filter output and product power supply terminal as short as possible.
- Tightly twisting the power cables is effective against noise.
- If the alarm function is not set correctly, it will not be output in case of abnormal operation, so please check it before operation.
- When replacing the sensor, be sure to turn off the power.
- Use an extra relay when the frequency of operation (such as proportional operation, etc.) is high, because connecting the load to the output relay rating without any room shortens the service life. In this case, SSR drive output type is recommended.
- When using electromagnetic switch: set the proportional cycle to at least 20 sec.
- When using SSR, set the proportional cycle to at least 1 sec.
- Do not wire anything to unused terminals.
- Please wire correctly, after checking the polarity of the terminals.
- When you install this product to a panel, please use switches or circuit breakers compliant with IEC60947-1 or IEC60947-3.
- Please install switches or circuit breakers at close distance for user convenience.
- Please specify on the panel that, since switches or circuit breakers are installed, if the switches or circuit breakers are activated, the power will be cut off.
- We recommend regular maintenance for the continuous safe use of this product.
- Some components of this product may have a lifespan or deteriorate over time.
- The warranty period of this product, is 1 year, including its accessories, under normal conditions of use.
- The preparation period of the contact output is required during power supply. If used as a signal to external interlock circuit, etc. please use a delay relay together.
- If the user changes the product in case of malfunctions, the operation may be different due to set parameters differences even if the model name is the same. So, please check the compatibility.
- Before using the temperature controller, there may be a temperature deviation between the PV value of the temperature controller and the actual temperature, so please use the product after calibrating the temperature deviation.

Ranges and input types

Classification	Code	Input type	Range	
			Celsius (°C)	Fahrenheit (°F)
Thermocouple	<i>U1</i>	K	-100 ~ 1200	-148 ~ 2192
	<i>U2</i>		-100.0 ~ 500.0	-148 ~ 932
	<i>J</i>	J	-100.0 ~ 500.0	-148 ~ 932
	<i>r</i>	R	0 ~ 1700	32 ~ 3092
RTD	<i>t</i>	T	-100.0 ~ 400.0	-148 ~ 752
	<i>Pt</i>	PT100 Ω	-100.0 ~ 400.0	-148.0 ~ 752.0

Part names and functions

Operation indicator

AT: Turns on during PID auto-tuning
 OUT: Turns on during control output operation
 AL1: Turns on during alarm 1 operation
 AL2: Turns on during alarm 2 operation
 LBA: Turns on during loop break alarm operation

PRESENT VALUE
(Displays present temperature on operation screen)

SET VALUE
(Displays set temperature on operation screen)

Name	Content
MODE Mode Key	Move among operation mode, user setup mode, and operator setup mode
Shift Key	Move set value row. Move among operation mode, user setup mode and operator setup mode.
Down Key	Decrease set value, move to parameter setting mode.
Up Key	Change operation mode, increase set value, shift parameter setting mode

Dimensions and panel cutout

Dimensions

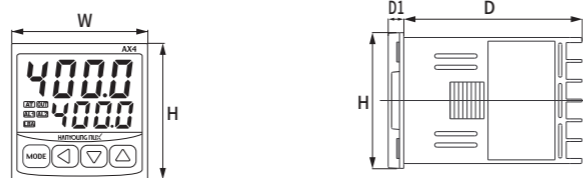

Panel cutout

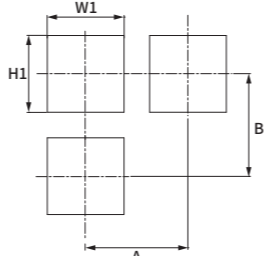

Classification	Type	AX2	AX3	AX4	AX7	AX9
Product dimensions	W	48.0	96.0	48.0	72.0	96.0
	H	96.0	48.0	48.0	72.0	96.0
	D	63.0	63.0	63.0	63.0	63.0
Panel cutout	D1	5.5	5.5	5.5	5.5	5.5
	W1	45.0	92.0	45.0	68.0	92.0
	H1	92.0	45.0	45.0	68.0	92.0
Panel cutout	A	70.0	122.0	60.0	83.0	117.0
	B	122.0	70.0	60.0	100.0	117.0

*±0.5 mm tolerance applied

Bracket assembling

● AX2, AX3, AX4, AX7, AX9

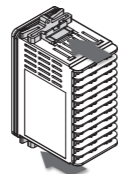

Case disassembling

● AX3, AX4, AX7, AX9 ● AX2

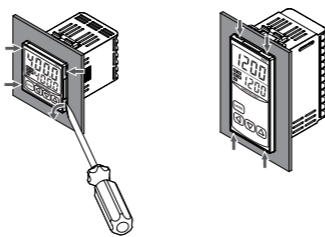

Main function description

Auto-tuning (AT)

The auto-tuning function automatically measures, computes the control system characteristics, and automatically sets the optimum proportional band (P), integral time (I), and derivative time (D) constants. Press and hold **MODE** and **MODE** simultaneously for more than 2 sec. to start the auto-tuning. When auto-tuning is terminated, the control starts automatically.

Alarm

● Alarm usage
 AX series supports 2 independent alarms (AL1 and AL2). These alarms can assign AL1 or AL2 signal to RLY1~RLY3 outputs and be used. If alarm signal is not assigned to RLY1~RLY3 then the menu related to the alarm will not be displayed.

Alarm hold operation

If the low alarm is turned ON while the power is supplied and the temperature increases, set **ALHd** (alarm n standby mode) to ON, in order to prevent the low alarm from turning ON while the temperature increases, and you will be able to prevent the low alarm operation from power on until the alarm set value is exited.

Alarm output LOCK

If the **ALoK** value is set to ON, alarm output is not cancelled even during alarm cancel condition, after the alarm is output.

Loop break alarm (LBA)

When the control output value by PID operation is "0%" or "100%" in the control system, it detects heater breaks and sensor break actuator breakdowns by comparing the change amount of measured value at each set time. You can also set the LBA deadband so that it is not affected by normal control loops.

- When control output value by PID operation is 100%, if the temperature does not increase more than **LbRu** value within the LBA set time, LBA output will turn ON.
- When control output value by PID operation is 0%, if the temperature does not decrease more than **LbRd** value within the LBA set time, LBA output will turn ON.

Time share cycle control and phase control of voltage pulse output ※ for SSR output only

When selecting control output type as SSR, you can select the voltage pulse output type. The time share cycle control turns ON/OFF the output by proportioning time to the output amount at regular time cycles. Set in the period **CE** parameter of control output. Within half cycle of power wave, the phase control controls the output amount by computing the output ON phase, depending on output amount.

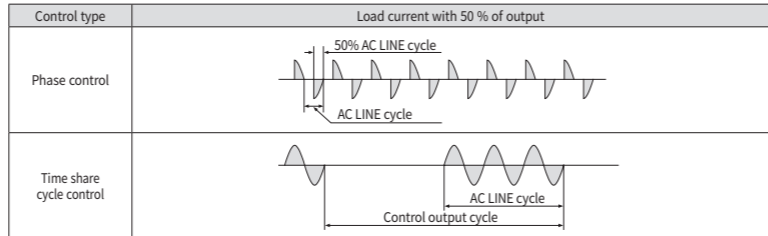

Operation mode

Supplying the power after wiring will display the current temperature. Every time you press **MODE** the set temperature and output amount will be displayed alternatively on the set value (SV) displaying unit.

User setup mode

User setup mode is the mode that sets the set values changed by users frequently such as alarm and loop break alarm (LBA) set values. The parameters of the operator setup mode are also displayed in the user setup mode, so that they can be easily set.

Symbol (PV)	List	Content	Display condition	Initial value (SV)
<i>Su</i>	Temperature set value (SV)	EU 0 ~ 100 %	Always displayed	EU 0%
<i>RL lL</i>	Alarm 1 low value	EU 0 ~ 100 % or EUS 0 ~ 100 % (temperature unit)	When ALn is set on RLYn	EU 0%
<i>RL lH</i>	Alarm 1 high value			EU 100%
<i>R ldb</i>	Alarm 1 deadband			EUS 0%
<i>RL 2L</i>	Alarm 2 low value			EU 0%
<i>RL 2H</i>	Alarm 2 high value			EU 100%
<i>R 2db</i>	Alarm 2 deadband			EUS 0%
<i>LbRt</i>	Loop break alarm time	0 ~ 7200 second	480	
<i>LbRu</i>	Loop break alarm temperature	0 ~ 100 °C (°F)	2	
<i>LbRd</i>	Loop break alarm deadband	0 ~ 100 °C (°F)	2	
<i>LoK</i>	Key lock	0 : No lock function 1 : Operator setup mode lock, auto-tuning inhibited 2 : Operator setup mode lock	Always displayed	0

Operator setup mode

Operator setup mode is the setting mode that sets the specifications of the temperature controller when the engineer installs it for the first time. Pressing **MODE** and **MODE** simultaneously for more than 2 sec. in the operation mode or user setup mode will enter to the operator setup mode. Pressing **MODE** and **MODE** again for more than 2 sec. will return to the operation mode.

Symbol (PV)	List	Content	Display condition	Initial value (SV)
<i>inp</i>	Input type	<i>U1</i> : K thermocouple (no decimal points) <i>U2</i> : K thermocouple (decimal points) <i>J</i> : J thermocouple <i>r</i> : R thermocouple <i>t</i> : T thermocouple <i>Pt</i> : PT100 Ω RTD	Always displayed	<i>U1</i>
<i>Unit</i>	Temperature unit	°C / °F selection	Always displayed	<i>°C</i>
<i>dP</i>	Decimal point display	ON (display), OFF (no display)	When selecting decimal point range	<i>on</i>
<i>biRS</i>	Input bias	-100 ~ 100 (sensor input value + bias)	Always displayed	<i>0</i>
<i>Flt</i>	Input filter time	0 ~ 120 sec.	Always displayed	<i>0</i>
<i>SLH</i>	High set limit	EU 0 ~ 100 %	Always displayed	<i>1200</i>
<i>SLL</i>	Low set limit	EU 0 ~ 100 %	Always displayed	<i>-100</i>
<i>oCtr</i>	Control output type	<i>SSr</i> : SSR drive voltage pulse output <i>rLY</i> : Relay output	When output selection is 1 or 2	<i>SSr</i>
<i>SSrt</i>	Voltage pulse output type	<i>CYc</i> : Time share proportional control <i>PHR</i> : SSR phase control (continuous proportion)	When selected SSR control output	<i>CYc</i>
<i>CE</i>	Control output cycle	0 ~ 1000 sec	When <i>SSrt</i> is CYC or <i>oCtr</i> is RLY	<i>2</i>
<i>Ctrd</i>	Control output operation	<i>rEu</i> : Reverse action (heating control) <i>dIr</i> : Direct action (cooling control)	Always displayed	<i>rEu</i>
<i>Ctrn</i>	Control type	<i>PId</i> : PID control <i>P</i> : P (proportional) control <i>onOFF</i> : ON/ OFF control	Always displayed	<i>PId</i>
<i>Pb</i>	Proportional band	1 (0.1) ~ EUS 100 %	When it is not ON/OFF control	<i>30</i>
<i>I</i>	Integral time	0 ~ 3600 sec	With PID control	<i>240</i>
<i>d</i>	Derivative time	0 ~ 3600 sec	With PID control	<i>60</i>
<i>nr</i>	Manual reset	0.0 ~ 100.0 %	With P control	<i>500</i>
<i>HYS</i>	Control hysteresis	EUS 0 ~ 100 % (temperature unit)	With ON/OFF control	<i>2</i>
<i>Pa</i>	Output amount with input break	0 ~ 100 %	Always displayed	<i>00</i>
<i>rLY1</i>	Relay 1 properties	<i>non</i> : Not using <i>RL1</i> : Alarm 1 output <i>RL2</i> : Alarm 2 output <i>LbR</i> : LBA output	When output selection is 1 or 2 and <i>oCtr</i> is not RLY	<i>non</i>
<i>rLY2</i>	Relay 2 properties	<i>non</i> : Not using <i>RL1</i> : Alarm 1 output <i>RL2</i> : Alarm 2 output <i>LbR</i> : LBA output	Always displayed	<i>RL1</i>
<i>rLY3</i>	Relay 3 properties	<i>non</i> : Not using <i>RL1</i> : Alarm 1 output <i>RL2</i> : Alarm 2 output <i>LbR</i> : LBA output	Always displayed (option)	<i>RL2</i>
<i>R lnd</i>	Alarm 1 mode (Alarm 1 or 2)	<i>non</i> : Not using ---[: High alarm]---- : Low alarm -[] : Alarm within range -]-[: Alarm out range	---	[---
<i>R 2nd</i>	Alarm 2 mode (Alarm 1 or 2)	---	---]----
<i>R lLy</i>	Alarm 1 type	<i>Rb5</i> : ABS (absolute alarm)	When AL1 or AL2 is set in RLY 1, 2, 3	<i>Rb5</i>
<i>R 2Ly</i>	Alarm 2 type	<i>dEu</i> : DEV (deviation alarm)		<i>oFF</i>
<i>R lHd</i>	Alarm 1 standby mode	<i>oFF</i> : OFF (not using standby mode) <i>on</i> : ON (using standby mode)		<i>oFF</i>
<i>R 2Hd</i>	Alarm 2 standby mode			<i>oFF</i>
<i>R lLy</i>	Alarm 1 delay time	0 ~ 9999 sec		<i>0</i>
<i>R 2Ly</i>	Alarm 2 delay time			<i>0</i>
<i>R lLoK</i>	Alarm 1 output lock	<i>oFF</i> : Alarm output return action <i>on</i> : Alarm output maintain action		<i>oFF</i>
<i>R 2LoK</i>	Alarm 2 output lock			<i>oFF</i>
<i>SuE</i>	Change SV on the operation screen	<i>oFF</i> : No change SV <i>on</i> : Change SV	Always displayed	<i>on</i>

SV change

① In operator setup mode, when **SuE** parameter value is **on**, you can change value on operation mode with **MODE**, **MODE**, **MODE** and set with **MODE** and set with **MODE**

Input error display

When input break (sensor break) occurs or when the maximum temperature range is exceeded, **boKt** will be displayed

Connection diagrams

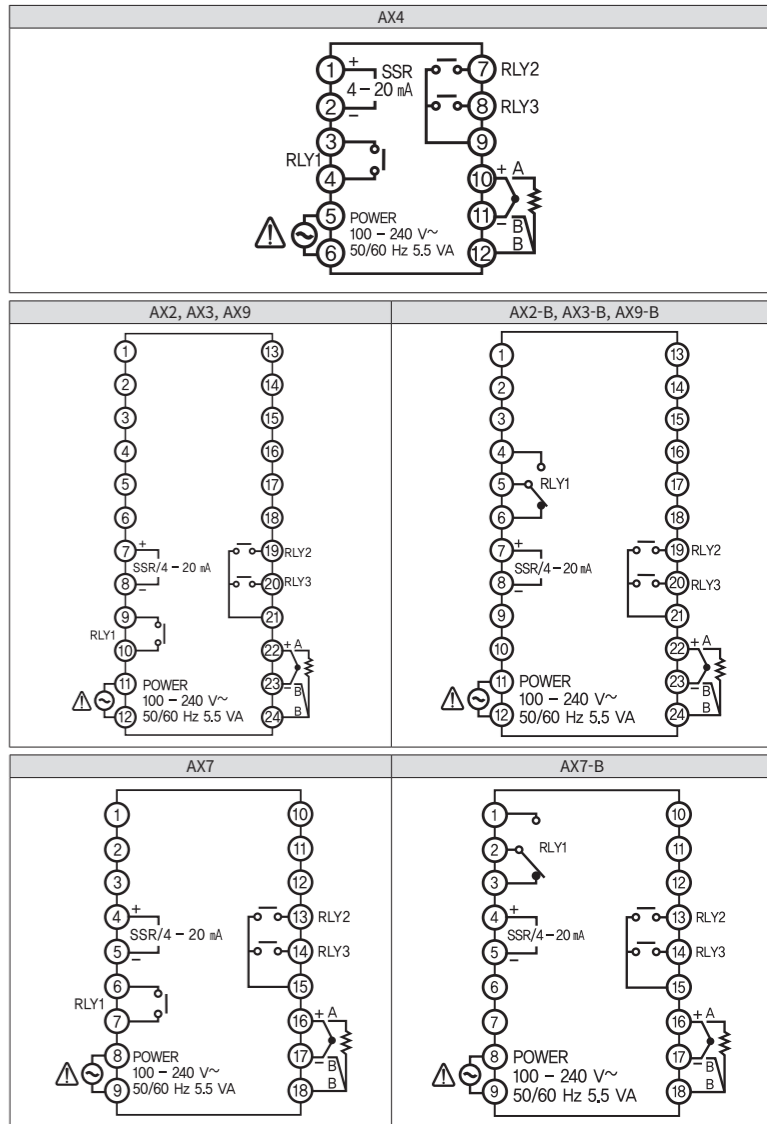

Parameter configuration

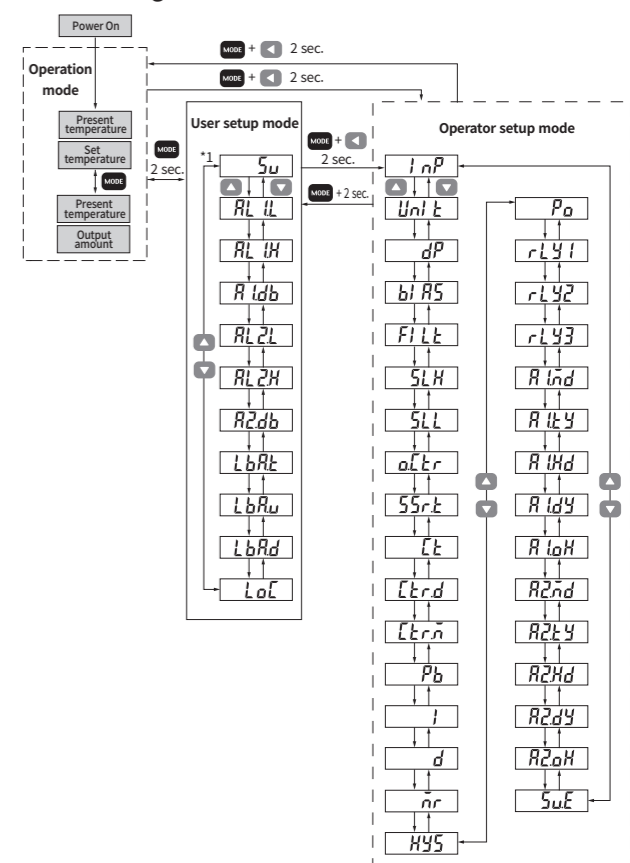

※ For further information, please visit our homepage (www.hanyoungnux.com) and refer to the user's manual in the archive.