

CXS CHEMICAL DRY VACUUM PUMPS





EDWARDS THE PARTNER OF CHOICE

Edwards is a world leader in the design, technology and manufacture of vacuum pumps with over 95 years' history.

Edwards believes in delivering results that bring value to our customers by using our breadth of industry experience to identify and apply solutions to your problems. Using the most innovative and up-to-date modelling techniques, we can optimise the pumping configuration for customers to provide a system design giving the maximum performance in the most reliable and cost-effective way.

EDWARDS' CXS CHEMICAL DRY VACUUM PUMPS

Edwards is synonymous with vacuum. Having hundreds of thousands of dry pumps installed worldwide, our high quality products and application know-how are renowned in the world of vacuum technology.

Featuring advanced tapered-screw technology for exceptional performance and energy efficiency, CXS vacuum pumps and combinations are at the cutting edge of chemical pump design

Simple – integral controller and safety system

- **Reduced installation costs:** easy integration with other systems

Reliable – cutting edge screw technology for corrosion-free operation and robust liquid and solids handling

- **Increased productivity:** longer intervals between services and no unplanned downtime

Economical – affordable capital investment and low cost of ownership

- **Reduced service costs:** minimal maintenance required
- **Substantial savings:** low utilities and energy costs

Environmental – dry, quiet-running technology

- **Comfortable workplace:** low vibration, quiet-running
- **Kinder on the environment:** no contaminated or dirty oil to dispose of



Simply Reliable

Performance

- Continuous vacuum from atmosphere to 10^{-3} mbar for a robust, repeatable process
- Deeper vacuum than traditional technologies and not limited by seal fluid or cooling water temperature

Control

- Integral PID pressure control with in-built inverter for consistent operation
- Data monitoring via on-board communication controller
- Special start-up and shutdown modes to free the rotors or avoid cold seizures, if required

Safety

- Explosion tested and certified by independent authorities to meet strict safety standards
- ATEX compliant for T4 IIB/IIB3 gases

Reliability

- No end-compression plate to create potential for trapped solids, jammed rotors and hydraulic locks
- No interstage condensers to create the potential for corrosion

Edwards' experience

- Hundreds of thousands of dry pumps installed worldwide
- Edwards supplies all 15 of the world's biggest and best known chemical and pharmaceutical manufacturers

Innovative screw technology

- Tapered-screw technology for improved thermal stability and optimised pumping at all inlet pressures
- The cooling system and compression technology deliver outstanding performance and active temperature control protects the pump from thermal shocks, condensation and corrosion

Efficient motor and inverter drive system

- Compact, high-speed motor with smaller footprint and lower noise
- High start torque for maximum restart capability and reduced bearings temperatures for longer life

ATEX Certification/Explosion Proof Certified

The CXS dry vacuum pump is ATEX certified, relying on constructional safety and containment for pumping gases from groups IIB/IIB3.

Solvent flush options, if necessary, can ensure constructional safety is maintained.

EXP systems

North American variants are suitable for Hazardous Locations Class 1, Groups C&D, Division 1 Environments. These variants are certified to NEC standards for Hazardous Areas.

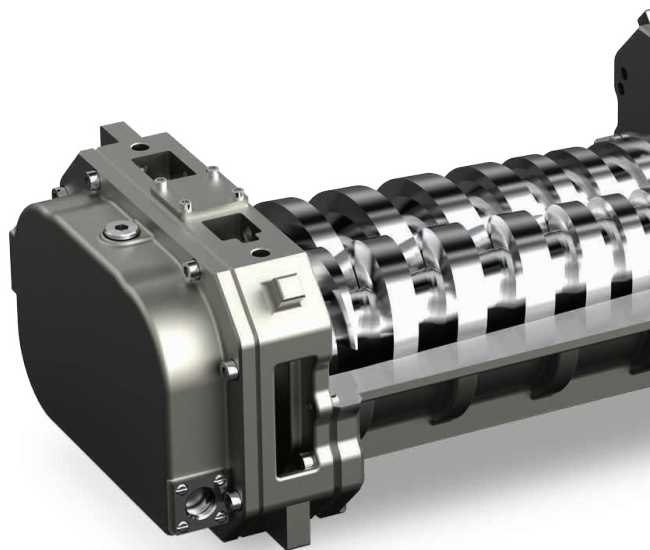

Applications

You can be assured Edwards has the application expertise and the CXS pump or integrated system solution to meet your needs.

- Drying
- Distillation
- Evaporation
- Polymerisation
- Reactor service
- House or central vacuum
- Flammable gases
- Corrosive gases
- Ethylene oxide sterilisation
- Degassing
- Deodorisation
- Solvent recovery
- Hydrogenation
- Pervaporation
- Absorption and desorption
- Crystallization
- Filtration
- Oil treatment

The Edwards CXS Chemical Dry Vacuum Pump can successfully handle:

- Acetates
- Adhesives
- Aldehydes
- Alcohols
- Amines
- Aromatics
- Ammonia
- Benzene
- Biofuels
- Bromides
- Chlorides
- Dimethyl Sulphide
- Diols
- Esters
- Ethers
- Ethylene Dichloride
- Ethylene Oxide
- Fatty acids and alcohols
- Glycerides
- Halides (HCl, HBr, HF)
- Hexane
- Hydrocarbons
- Hydrogen
- Isocyanates
- Ketones
- Mineral acids
- MEK (Methyl Ethyl Ketone)
- Nitric Acid
- Organic Acids
- Paraffins
- Pentane
- Phenol
- Phosgene
- Phosphoric Acid
- Polycarbonates
- Polyglycols
- Sulphides
- Sulphuric Acid
- Siloxanes
- Thionyl Chloride
- Toluene
- Triethylamine
- Tetrahydrofuran
- Water
- Xylene

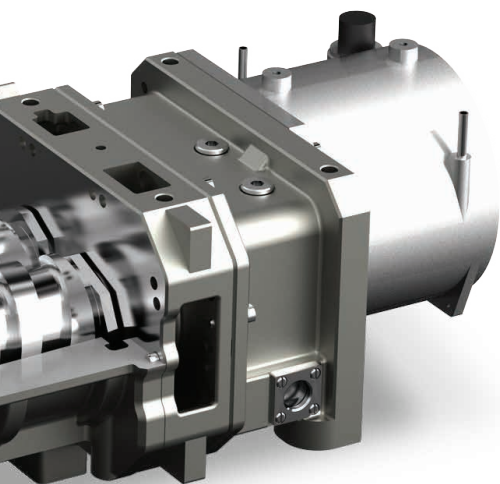

Applications knowledge

Expert applications engineering is central to Edwards' success. We always provide solutions to customer problems. This can involve:

- Process design
- Equipment selection
- Integration into the plant control philosophy
- Safety considerations
- Advice at start-up, commissioning and training

Our experienced applications team are trained to provide expert advice on designing the correct pumping system.

Technical data

Specification	Units	CXS160	CXS250
Maximum pumping speed	m ³ h ⁻¹	160	250
	ft ³ min ⁻¹	95	148
Capacity at 10 mbar (7.5 Torr)	m ³ h ⁻¹	132	230
	ft ³ min ⁻¹	78	135
Ultimate vacuum	mbar	<0.02	<0.015
	Torr	<0.015	<0.011
Maximum back pressure - standard	mbar	1,200	1,200
	psig	2.7	2.7
Power consumption at 10 mbar (7.5 Torr)	kW	3.6	3.8
	hp	4.8	5.1
Standard motor (380 - 460V ±10%, 3 ph, 50/60 Hz)	kW	7.5	7.5
	hp	10	10
Cooling water flow rate (adjustable)	l min ⁻¹	4 - 10	4 - 10
	gal min ⁻¹	1.1 - 2.6	1.1 - 2.6
Cooling water temperature	°C	5 - 35	5 - 35
	°F	41 - 95	41 - 95
Maximum cooling water supply pressure	barg	6.9	6.9
	psig	100	100
Cooling water supply differential pressure	bar	0.6 - 1.7	0.6 - 1.7
	psi	9 - 24	9 - 24
Seal purge flow (maximum)	std l min ⁻¹	12	12
	std ft ³ min ⁻¹	0.424	0.424
Seal purge supply pressure (minimum - maximum)	barg	2.5 - 6.9	2.5 - 6.9
	psig	36 - 100	36 - 100
Noise (maximum) with silencer	dB(A)	64	64
Weight (with frame and standard motor)	kg	470	470
	lbs	1,034	1,034
Process connection, inlet	ANSI/DIN	3"/DN80	3"/DN80
Process connection, outlet	ANSI/DIN	2"/DN50	2"/DN50

Performance

CXS160 and CXS250



- CXS160 (50/60Hz)
- CXS250 (50/60Hz)

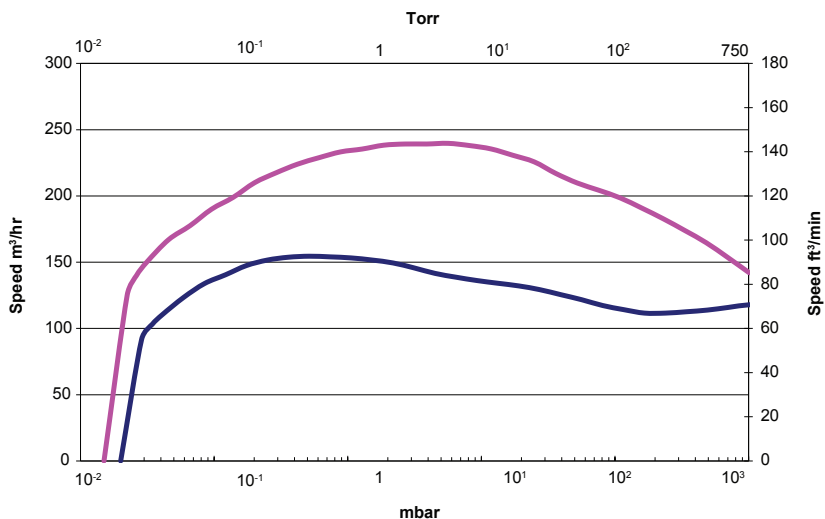

CXS160 combinations



- CXS160+EH1200 (60Hz)
- CXS160+EH1200 (50Hz)
- CXS160+EH500 (60Hz)
- CXS160+EH500 (50Hz)
- CXS160 (50/60Hz)

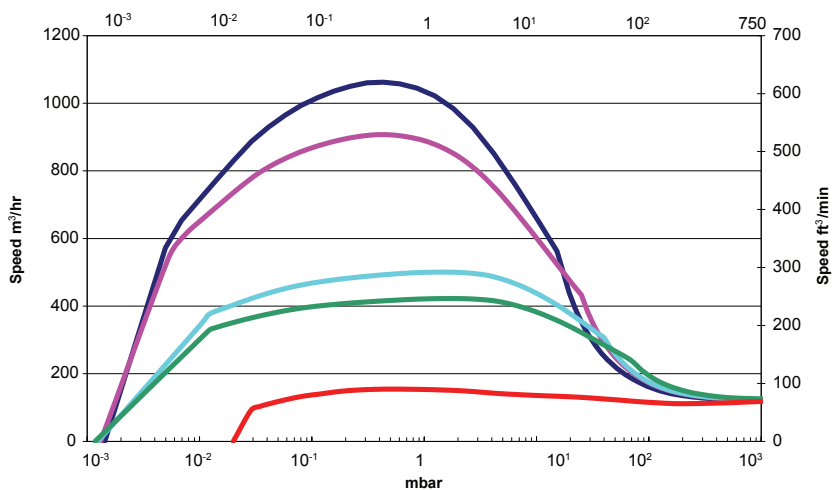

*Without booster gearbox purge; mandatory for ATEX compliance

CXS250 combinations



- CXS250+EH2600 (60Hz)
- CXS250+EH2600 (50Hz)
- CXS250+EH1200 (60Hz)
- CXS250+EH1200 (50Hz)
- CXS250

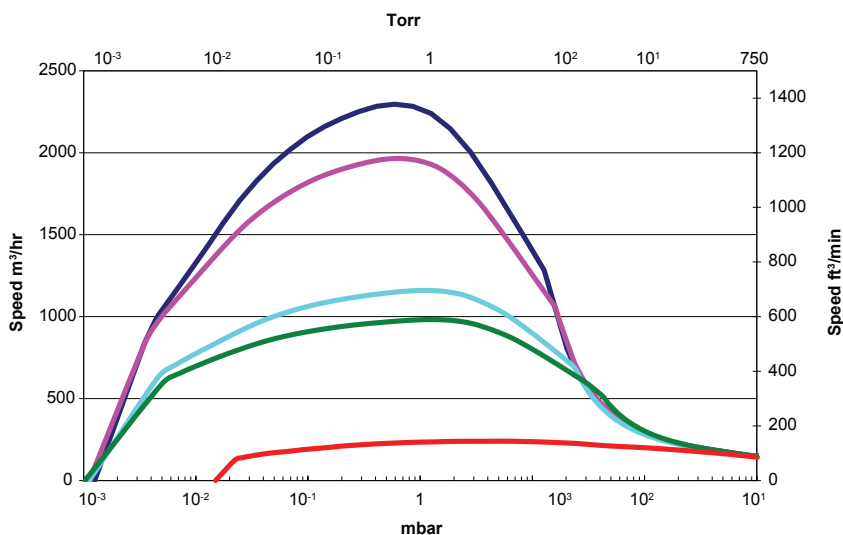

Pump dimensions - CXS160/250

Standard CXS pump

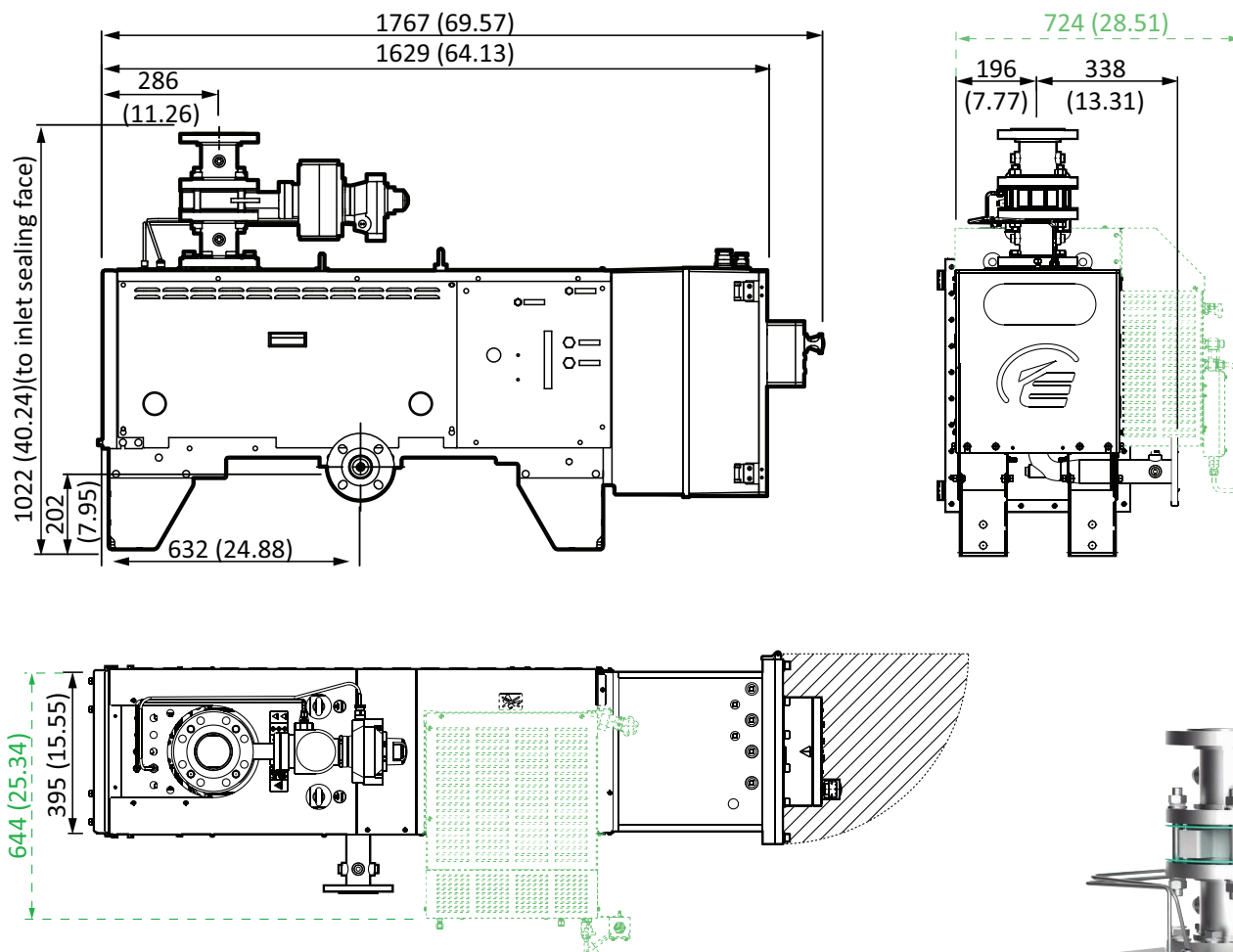

Dimensions in mm (inch)

ATEX version drawings shown. Portions & dimensions in green denote the Americas variant differences



CXS pump with booster combinations

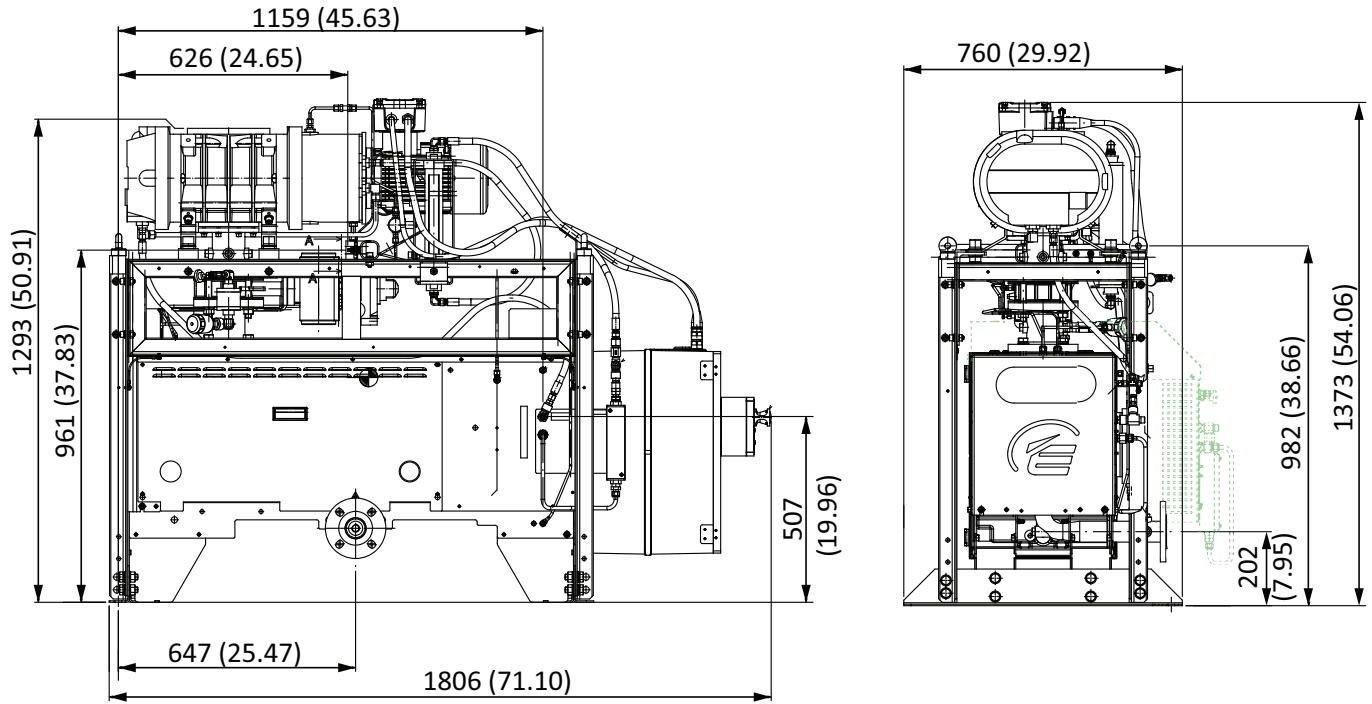

Dimensions in mm (inch)

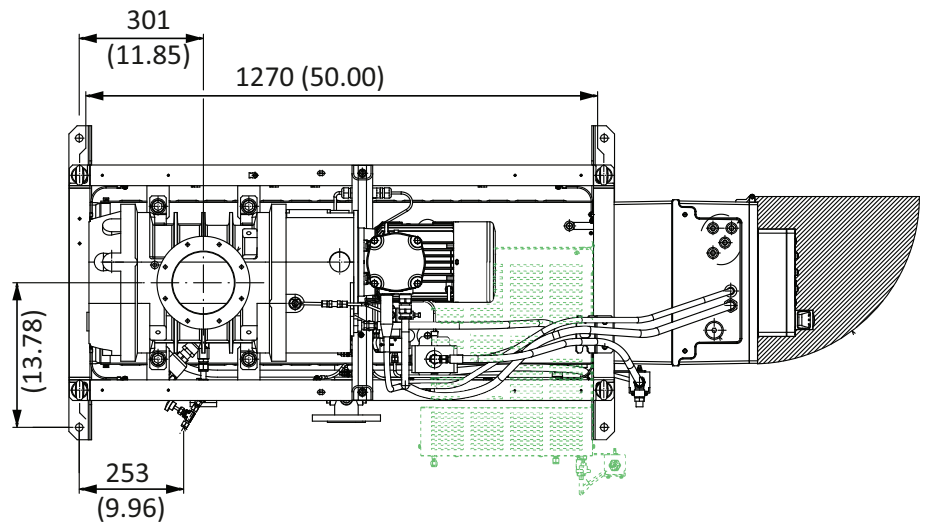

ATEX version drawings shown. Portions & dimensions in green denote the Americas variant differences

CXS systemisation

Using an extensive range of pre-engineered modules Edwards' CXS offers the capability to match most customer application needs.

Systemisation is simple with CXS pumps:

- Multiple applications for one single design
- Shorter lead time
- Quick assembly of complex systems
- Reduced engineering costs

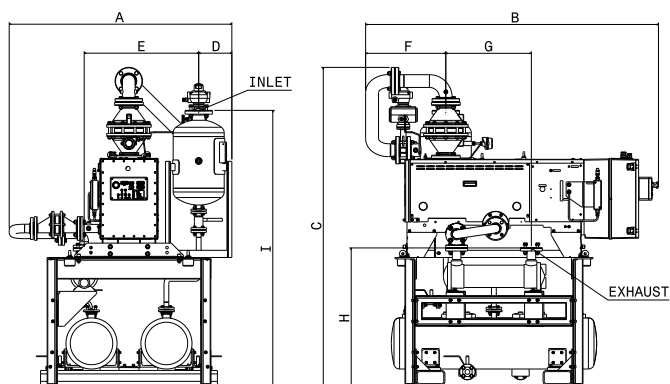

Configuration	Connections		Dimensions (mm)								
	INLET	OUTLET	A	B	C	D	E	F	G	H	I
CXS 160/250	3" ANSI/DN80	2" ANSI	1360	2045	1830	235	800	560	600	970	1590
CXS 160/250 + Flame Arrestor Option	3" ANSI/DN80	2" ANSI	1555	2045	2225	235	800	560	600	970	1930

Configuration	Connections		Dimensions (mm)								
	INLET	OUTLET	A	B	C	D	E	F	G	H	I
CXS 160/250 +EH1200	ISO160	2" ANSI	1360	2045	2275	720	315	560	600	970	2200
CXS 160/250 +EH1200+ Flame Arrestor Option	ISO160	2" ANSI	1555	2045	2670	720	315	560	600	970	2595

Images not shown. Typical dimensions of booster combinations.

- Various flame arrestors available. These are representative drawings only. Please contact Edwards for detailed drawings.
- Edwards' EH series boosters feature our unique hydrokinetic drive which can have significant cost and performance advantages over direct drive machines. The hydrokinetic drive removes any need for pressure sensors or by-pass lines or inverters, and allows the booster to run from atmospheric pressure to ultimate vacuum, giving faster pumpdown and more flexible operation with less maintenance.

Service and Support

Your business success depends on maximum equipment uptime and minimum total cost of ownership, and we constantly strive to support those objectives. As a global leader in vacuum technology and processes, we understand how vacuum pumps and systems perform in real life. Our wide portfolio of services is designed with you in mind: to help keep your processes and equipment running in the most economical and environmentally efficient manner.

Services include:

- Overhaul and repair using genuine Edwards OEM parts
- OEM spares and kits available for immediate despatch
- Remanufactured products available for cost-effective expansion and backups
- Global network of expert field service engineers available to respond quickly to unexpected equipment failures
- Extended warranty, to help manage the cost of the unexpected

Our Expert Advantage Service Plans provide you with the ongoing support necessary to continuously improve your operational efficiency and meet your business objectives. As service offerings may vary slightly from product to product, please contact your Edwards representative to discuss your specific requirements.

CXS ordering information

CXS Pump part numbers

CXS160 and EH Booster Combinations	
CXS160 ATEX CAT2 T3 Light Duty	CS2560000000
CXS160 ATEX CAT2 T3 Medium Duty +	CS2561005000
CXS160/EH1200 ATEX CAT2 Light Duty	CS6560000000
CXS160/EH1200 ATEX CAT2 Medium Duty +	CS6561005000
CXS160 CL1DIV1 T3 HV MD+	CS2511005000
CXS160 CL1DIV1 T3 HV FAE MD+	CS2511205000

CXS250 and EH Booster Combinations	
CXS250 ATEX CAT2 T3 Light Duty	CS9560000000
CXS250 ATEX CAT2 T3 Medium Duty +	CS9561005000
CXS250/EH1200 ATEX CAT2 T3 Light Duty	CSB5600000000
CXS250/EH1200 ATEX CAT2 T3 Medium Duty +	CSB561005000
CXS250/EH2600 ATEX CAT2 T3 Light Duty	CSD5600000000
CXS250/EH2600 ATEX CAT2 T3 Medium Duty +	CSD561005000
CXS250 CL1DIV1 T3 HV MD+	CS9511005000
CXS250 CL1DIV1 T3 HV FAE MD+	CS9511205000

CXS Accessories	
Order No.	Description
M52808600	Exhaust Manual Isolation Valve Kit
M52808300	Solvent Flush Assembly
M52808550	Exhaust Silencer Assembly
M52809280	CXS Exhaust temperature transmitter accessory kit
M52809200	CXS Inlet pressure transmitter
M52805170	CXS Gas purge flow meter accessory kit
M52808460	CXS Inlet pressure indicator accessory kit
M52808480	CXS Exhaust pressure indicator accessory kit
M52809160	CXS Inlet temperature indicator accessory kit
M52809170	CXS Exhaust temperature indicator accessory kit

The requirement for these or other accessories is determined through expert applications engineering.

Light Duty includes Shaft Seal Purges (SSP) only for clean applications.

Medium Duty + includes SSP, gas ballast, inlet purge, solvent flush and exhaust pressure monitoring for harsh processes.

These products are our offering for the majority of applications.

A comprehensive 'matrix' of CXS products are available including the following:

- Containment safety ATEX CAT2 products with integral Flame Arrestors
- Fully systemised ATEX CAT 1 external / CAT2 external products
- T160 and T4 products

Please consult your Edwards Sales or Applications specialist for assistance with the correct product selection.



GLOBAL CONTACTS

Publication Number: 3602 101 6 01
 © Edwards Limited 2016. All rights reserved
 Edwards and the Edwards logo are trademarks of
 Edwards Limited

Whilst we make every effort to ensure that we
 accurately describe our products and services,
 we give no guarantee as to the accuracy or
 completeness of any information provided in
 this brochure.

Edwards Ltd, registered in England and Wales
 No. 6124750, registered office: Innovation Drive,
 Burgess Hill, West Sussex, RH15 9TW, UK.

EMEA

UK	+44 1444 253 000 (local rate) 08459 212223
Belgium	+32 2 300 0730
France	+33 1 4121 1256
Germany	0800 000 1456
Italy	+ 39 02 48 4471
Israel	+ 972 8 681 0633

ASIA PACIFIC

China	+86 400 111 9618
India	+91 20 4075 2222
Japan	+81 47 458 8836
Korea	+82 31 716 7070
Singapore	+65 6546 8408
Taiwan	+886 3758 1000

AMERICAS

USA	+1 800 848 9800
Brazil	+55 11 3952 5000