

# CDX1000-1300 DRY SCREW VACUUM PUMPS

 **EDWARDS**



## EDWARDS THE PARTNER OF CHOICE

Edwards is a world leader in the design, technology and manufacture of vacuum pumps for industrial applications with over 100 years' history.

We believe in delivering results that bring value to our customers by using our breadth of industry experience to identify and apply solutions. Using the most innovative and up-to-date modelling techniques, we can optimise the pumping configuration for customers to provide a system design giving the maximum performance in the most reliable and cost-effective way.

## DRY PUMP TECHNOLOGY

Edwards is a market leader in dry pump technology and a pioneer of dry vacuum for the chemical process, pharmaceutical and fine chemical industries. The CDX1000-1300 dry screw vacuum pumps are optimised for processes requiring large pumping speeds and are best suited for demanding applications within this sector. It's innovative double screw ended technology leverages Edwards' smart manufacturing and design philosophies. Installed mainly in continuous, large, high throughput environments; this pump has been designed to withstand process malfunctions and to minimise down time from line maintenance to overhaul. These dry pumping systems reduce energy costs, eliminate effluent and can give significant improvements in product quality compared to oil-sealed or liquid ring vacuum pump technology.



### Reliable design

Simple, rugged double ended screw design for reliable performance



### Tighter temperature control

Indirect cooling and oil cooled rotors ensure consistent temperature control



### Protection from process

Excellent dust, particulate and liquid handling for process repeatability



### Ease of service

Designed for service, with easy on-site maintenance allowing for maximum uptime

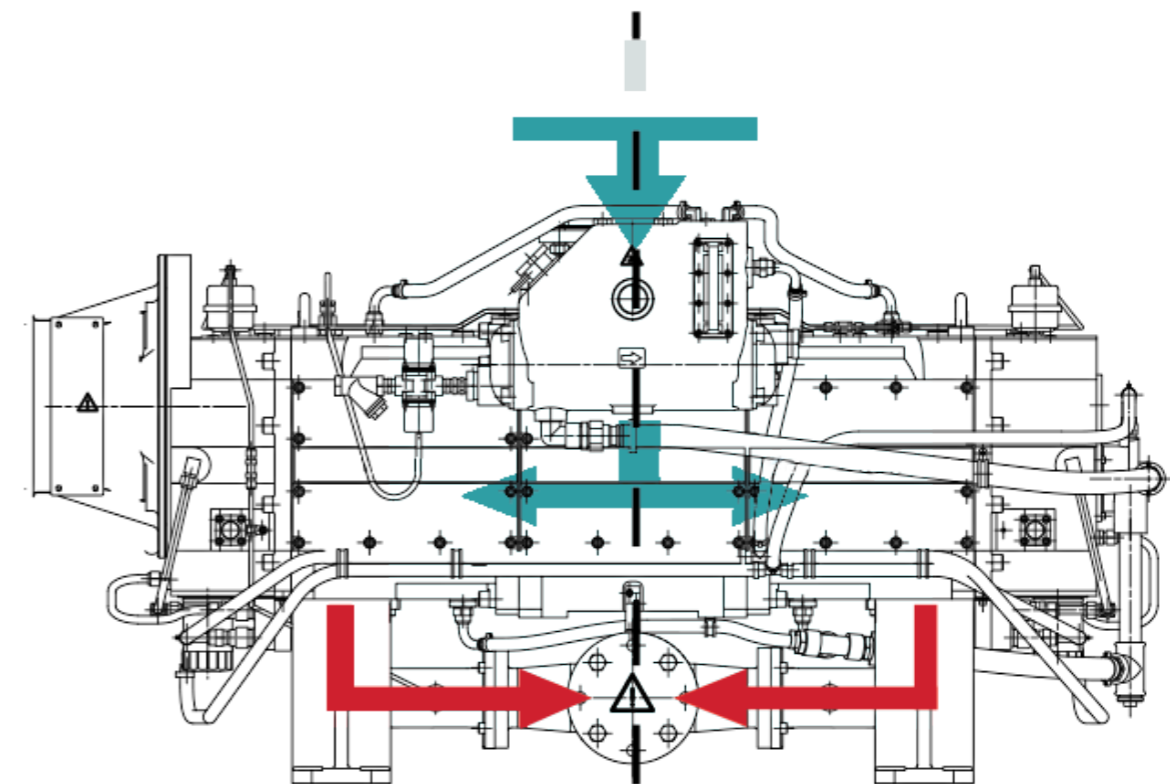

Compression in 2 smaller volumes



### High tolerance

The pump's dependable dust and particulate tolerance ensures no expansion volumes or no cold seizures



### Tailored to match your needs

Customised systems available for a wide range of processes ensuring better performance and control options



### Easy to control

Cooled, filtered oil system and direct on-line start ensure hassle-free operations from initial installation and throughout lifecycle



### Excellent liquid handling

Pump is equipped with a self-draining mechanism with no compression plate and no hydraulic lock



### High longevity

Limiting the oil temperature prevents carburisation and degradation, extending bearing and seal life



### Minimal process line disturbance

Flame arrestors available as option can be cleaned and inspected without breaking process lines and silencers are drainable and cleanable



## SYSTEMISATION

As no two installations are identical, Edwards offers a custom systemisation design and build service, exactly matched to customer needs, using pre-engineered modules together with an extensive CAD capability. This also allows subsequent expansion or reconfiguration. A wide range of modules is available, including:

- Knockout pots
- Dust filters
- Solvent purging
- Flame arrestors
- Instrumentation
- Silencers
- Documentation
- Base skids
- EH, HV and GMB mechanical booster pumps
- Isolation and throttle control valves
- Inverter drives and pressure controls
- Electrical control panels
- Air blast closed-loop cooling
- Condensers
- Receivers

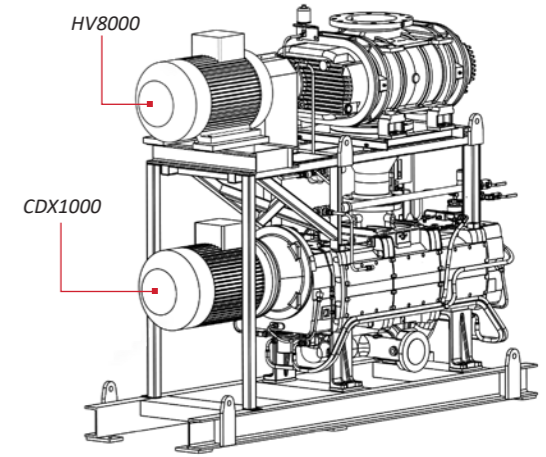

CDX1000 and HV8000 booster combination

The requirement for these or other accessories is clarified through expert applications engineering. Work can be carried out to a customer's specifications, or to local or industry standard codes and practices.

## APPLICATIONS

- Distillation
- Fine chemicals
- Speciality chemicals
- Petrochemicals
- Flammable and corrosive gases
- Pharmaceuticals
- Lithium-ion batteries
- Solar crystal pulling
- Dewatering and filtration

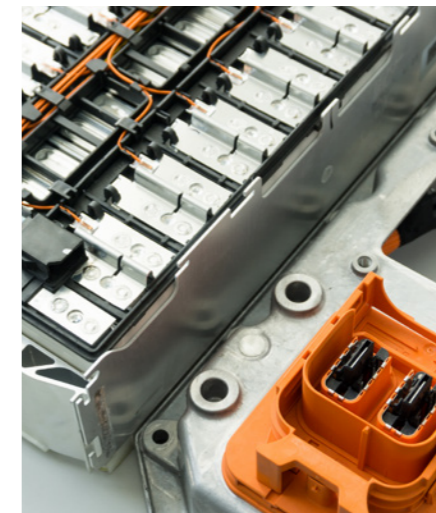

## PERFORMANCE CURVES

CDX1000

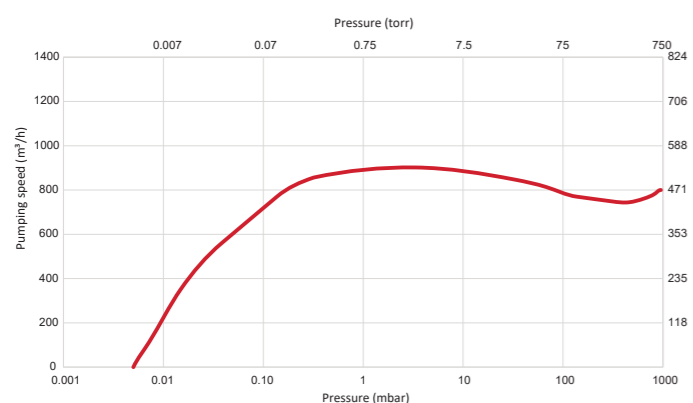

CDX1300

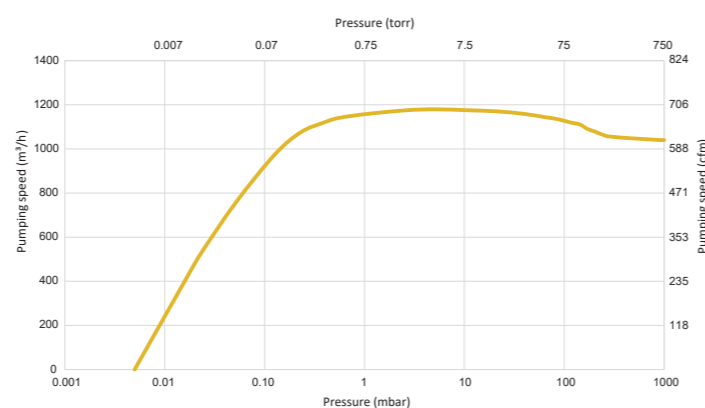

## TECHNICAL SPECIFICATIONS

	Units	CDX1000	CDX1300
Peak pumping speed	m <sup>3</sup> /hr	900	1200
	cfm	530	706
Ultimate pressure	mbar	0.05	
	torr	0.04	
Maximum back pressure	mbar	1150	1050
Motor power	kW	30	
	hp	40	
Cooling water minimum flow	l/min	10	
Cooling water supply temp. range	°C	5-35	
Cooling water supply pressure	bar	10	
Cooling water minimum flow rate at 20° C supply temp.	l/min	10	
Purge gas supply pressure	bar	2-10	
Regulated pressure to shaft seals	bar	0.3-0.5	
Noise (max. with exhaust silencer)	dB	82	
Weight (with motor)	kg	1710	1760
Pump Inlet		150 DN PN16 /6" ANSI	150 DN PN16
Pump Outlet		80 DN PN16 /3" ANSI	80 DN PN16

## ORDERING INFORMATION

Part number	Product description	HazLoc certification
A70802985	CDX1000 Bareshaft - 50Hz Std DIN flange	Internal: Ex II 2 G Ex h IIC T3, T4 Gb External: Ex II 2 G Ex h IIC T3, T160 °C, T4 Gb
A70812985	CDX1000 Bareshaft - 60Hz Std ANSI flange	
A70905985	CDX1300 Bareshaft - 60Hz Std DIN flange	Internal: Ex II 2 G Ex h IIC T3 Gb External: Ex II 2 G Ex h IIC T3 Gb

Motorised version also available on request

## DIMENSIONS

CDX1000 (Motorised)

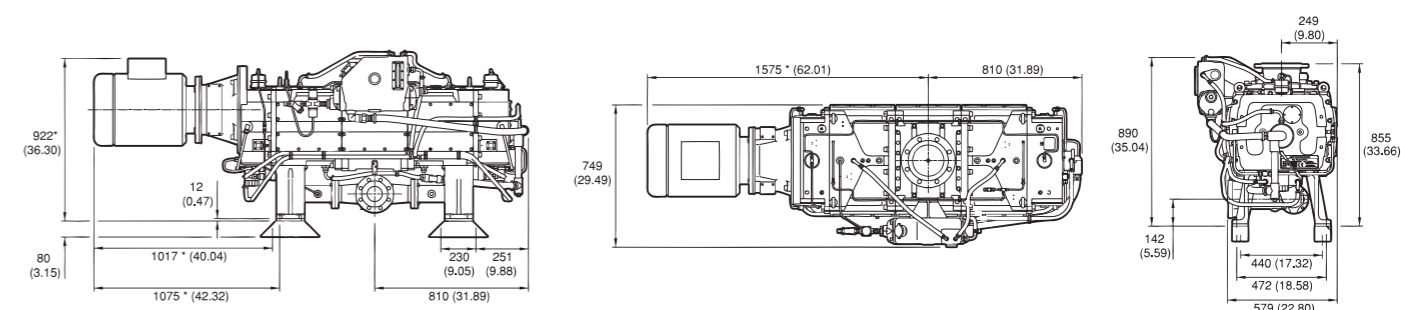

CDX1300 (Non-motorised)

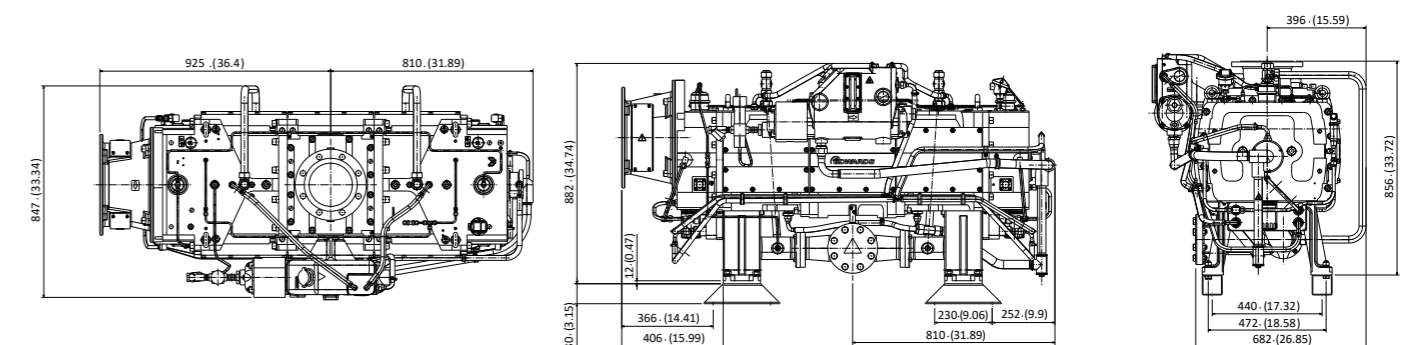

## SERVICE AND SUPPORT

To ensure your CDX pump maintains optimal performance and reliability, we propose a wide range of service solutions tailored to meet your needs. To save time and money, we recommend that you service your pump using the original spare kits we offer. It is quick, easy and safe. In case of difficulties, our professional and trained Field Service Engineers are always available to provide the appropriate service.

Selecting original spare parts, kits and grease, means that every critical part performs as intended and ensures you receive the best result from each and every service. Form, fit and function are guaranteed.





Publication Number: 3602 120 4 01  
© Edwards Limited 04.2024. All rights reserved  
Edwards and the Edwards logo are trademarks of  
Edwards Limited.

Whilst we make every effort to ensure that we  
accurately describe our products and services,  
we give no guarantee as to the accuracy or  
completeness of any information provided in  
this brochure.

Edwards Ltd., registered in England and Wales  
No. 6124750, registered office: Innovation Drive,  
Burgess Hill, West Sussex, RH15 9TW,  
United Kingdom.