

50 mm Diameter Absolute Multi-Turn Rotary Encoders (Magnetic)

MGAM50 Series INSTRUCTION MANUAL

TCD210039AB

Thank you for choosing our Autonics product.

Read and understand the instruction manual and manual thoroughly before using the product.

For your safety, read and follow the below safety considerations before using.

For your safety, read and follow the considerations written in the instruction manual, other manuals and Autonics website.

Keep this instruction manual in a place where you can find easily.

The specifications, dimensions, etc. are subject to change without notice for product improvement. Some models may be discontinued without notice.

Follow Autonics website for the latest information.

Safety Considerations

- Observe all 'Safety Considerations' for safe and proper operation to avoid hazards.
- ⚠ symbol indicates caution due to special circumstances in which hazards may occur.

⚠ Warning Failure to follow instructions may result in serious injury or death.

01. Fail-safe device must be installed when using the unit with machinery that may cause serious injury or substantial economic loss. (e.g. nuclear power control, medical equipment, ships, vehicles, railways, aircraft, combustion apparatus, safety equipment, crime / disaster prevention devices, etc.)
Failure to follow this instruction may result in personal injury, economic loss or fire.

02. Do not use the unit in the place where flammable / explosive / corrosive gas, high humidity, direct sunlight, radiant heat, vibration, impact or salinity may be present.
Failure to follow this instruction may result in explosion or fire.

03. Install on a device panel to use.

Failure to follow this instruction may result in fire.

04. Do not connect, repair, or inspect the unit while connected to a power source.

Failure to follow this instruction may result in fire.

05. Check 'Connections' before wiring.

Failure to follow this instruction may result in fire.

06. Do not disassemble or modify the unit.

Failure to follow this instruction may result in fire.

⚠ Caution Failure to follow instructions may result in injury or product damage.

01. Use the unit within the rated specifications.

Failure to follow this instruction may result in injury or product damage.

02. Do not short the load.

Failure to follow this instruction may result in fire.

03. Do not use the unit near the place where there is the equipment which generates strong magnetic force or high frequency noise and strong alkaline, strong acidic exists.

Failure to follow this instruction may result in product damage.

Cautions during Use

- Follow instructions in 'Cautions during Use'. Otherwise, It may cause unexpected accidents.
- 12 - 24 VDC≐ power supply should be insulated and limited voltage / current or Class 2, SELV power supply device.
- For using the unit with the equipment which generates noise (switching regulator, inverter, servo motor, etc.), ground the shield wire to the F.G. terminal.
- Ground the shield wire to the F.G. terminal.
- When supplying power with SMPS, ground the F.G. terminal and connect the noise canceling capacitor between the 0 V and F.G. terminals.
- Wire as short as possible and keep away from high voltage lines or power lines, to prevent inductive noise.
- Check the wire type and response frequency when extending wire because of distortion of waveform or residual voltage increment etc. by line resistance or capacity between lines.
- This unit may be used in the following environments.
 - Indoors (in the environment condition rated in 'Specifications')
 - Altitude max. 2,000 m
 - Pollution degree 2
 - Installation category II

Cautions during Installation

- Install the unit correctly with the usage environment, location, and the designated specifications.
- Do not load overweight on the shaft.
- Do not put strong impact when insert a coupling into shaft.
Failure to follow this instruction may result in product damage.
- When fixing the product or coupling with a wrench, tighten under 0.15 N·m.
- If the coupling error (parallel misalignment, angular misalignment) between the shaft increases while installation, the life cycle of the coupling and the encoder can be shorten.
- Do not apply tensile strength over 30 N to the cable.

Ordering Information

This is only for reference, the actual product does not support all combinations. For selecting the specified model, follow the Autonics website.

MGAM50 ① ② - ③ ④ - ⑤ - ⑥ - ⑦ - ⑧

① Shaft type

S: Shaft type

② Shaft outer diameter

8: Ø 8 mm

③ Single-turn resolution

10: 10 bit (1024-division)

④ Multi-turn resolution

13: 13 bit (8192-revolution)

⑤ Output code

B: Binary code

⑥ Rotating direction

F: Increase output when the rotating direction is clockwise base on facing the shaft
R: Increase output when the rotating direction is counter-clockwise base on facing the shaft

⑦ Control output

PN: Parallel NPN open collector output
S: SSI Line driver output

⑧ Power supply

24: 12 - 24 VDC≐ ±5%

Product Components

- Product × 1
- Instruction manual × 1
- Bolt × 7
- Coupling × 1
- Bracket × 1

Connections

- Unused wires must be insulated.
- The metal case and shield cable of encoders must be grounded (F.G.).
- F.G. (Frame Ground) must be grounded separately.
- Since exclusive driver IC is used for output circuit, be aware of short circuits when wiring each output wires.
- N · C: not connected

■ Parallel NPN open collector output

- Multi-turn count (sheath: black)

Color	Function	Refer
White	N · C	
Black	N · C	
Brown	2 ⁰	Multi-turn count
Red	2 ¹	
Orange	2 ²	
Yellow	2 ³	
Green	2 ⁴	
Blue	2 ⁵	
Purple	2 ⁶	
Gray	2 ⁷	
Pink	2 ⁸	
Clear	2 ⁹	
Light brown	2 ¹⁰	
Light yellow	2 ¹¹	
Light green	2 ¹²	
Light blue	Overflow alarm (OVF)	
Light purple	Multi-turn count reset	
Shield	F.G.	Signal shield

- Single-turn data (sheath: gray)

Color	Function	Refer
White	+V	Power
Black	GND	
Brown	2 ⁰	
Red	2 ¹	Single-turn data
Orange	2 ²	
Yellow	2 ³	
Green	2 ⁴	
Blue	2 ⁵	
Purple	2 ⁶	
Gray	2 ⁷	
Pink	2 ⁸	
Clear	2 ⁹	
Light brown	N · C	
Light yellow	N · C	
Light green	N · C	
Light blue	N · C	
Light purple	N · C	
Shield	F.G.	Signal shield

■ SSI Line driver output

Color	Function	Refer	
White	+V	Power	
Black	GND		
Brown	CLOCK+		
Red	CLOCK-	SSI	
Orange	DATA+		
Yellow	DATA-		
Gray	N · C	COMMAND	
Blue	N · C		
Purple	N · C		
Green	Multi-turn count reset		
Shield	F.G.		Signal shield

Inner Circuit

- The output circuit is identical for each output bit.
- Be aware of circuit break in case of overload or short beyond the specifications.

■ Parallel NPN open collector output

- COMMAND input

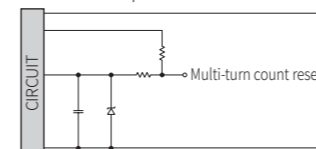

- Output

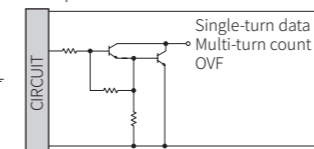

■ SSI Line driver output

- CLOCK input

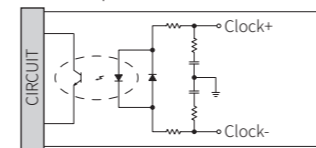

- COMMAND input

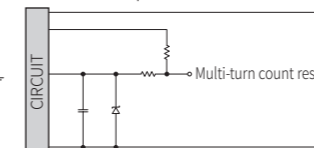

- Output

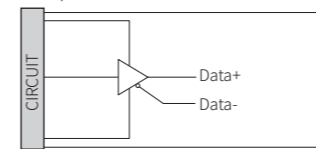

Specifications

Model	MGAM50S8-1013-B-F-PN-24	MGAM50S8-1013-B-F-S-24
Resolution	Single-turn: 1024 division Multi-turn: 8192 revolution	
Rotation limit when power OFF ⁰¹⁾	± 90°	
Hysteresis	± 0.1°	
Positioning error ⁰²⁾	± 1 bit (LSB: Least Significant Bit)	
Output code	Binary 2 code	24 bit, Binary 2 code
Output signal	Single-turn data, Multi-turn count, Overflow alarm (OVF) ⁰³⁾	SSI (Synchronous Serial Interface) Line driver output
Control output	Parallel NPN open collector output	SSI (Synchronous Serial Interface) Line driver output
Inflow current	≤ 20 mA	≤ 20 mA
Residual voltage	≤ 1 VDC≐	≤ 0.5 VDC≐
Outflow current	-	≤ -20 mA
Output voltage	-	≥ 2.5 VDC≐
Output logic	Negative logic output	-
Response speed ⁰⁴⁾	≤ 1 μs	-
Multi-turn count reset	Input level: 0 - 1 VDC≐ Input logic: Low Active, Open for common use Input time: ≥ 100 ms	
Clock	-	Input level: 5 VDC≐ ± 5% Input frequency: 100 kHz to 1 MHz
Max. response freq.	30 kHz	-
Max. allowable revolution ⁰⁵⁾	3,000 rpm	
Starting torque	≤ 0.0069 N·m	
Inertia moment	≤ 80 g·cm ² (8 × 10 ⁻⁶ kg·m ²)	
Allowable shaft load	Radial: 10 kgf, Thrust: 2.5 kgf	
Unit weight (packaged)	≈ 393 g (≈ 523 g)	≈ 261 g (≈ 391 g)
Approval	CE ㉿ ㉿ ㉿	

01) It calibrates the multi-turn count by comparing single-turn data before/after power off without counting multi-turn count when power off. Correct multi-turn count cannot be obtained if a rotating operation exceeding ± 90° is performed at the rotation position when power off. Use within the condition of rated rotating operation.

02) When power ON / OFF the unit, ± 1 bit (LSB) can be changed at current position due to hysteresis.

03) Outputs when multi-turn count is out of counting range (0 to 8191 revolution).

04) Based on cable length: 2 m, I sink = 20 mA

05) For parallel model Select resolution to satisfy Max. allowable revolution ≥ Max. response revolution

$$\frac{\text{max. response revolution (rpm)}}{\text{resolution}} \geq \frac{\text{max. response frequency}}{\text{resolution}} \times 60 \text{ sec}$$

Power supply	12 - 24 VDC≐ ± 5% (ripple P-P: ≤ 5%)
Current consumption	Parallel NPN open collector output ≤ 100 mA (no load) SSI Line driver output ≤ 150 mA (no load)
Insulation resistance	≥ 100 MΩ (500 VDC≐ megger)
Dielectric strength	Between the charging part and the case: 750 VAC~ 50 / 60 Hz for 1 min.
Vibration	1 mm double amplitude at frequency 10 to 55 Hz in each X, Y, Z direction for 2 hours
Shock	≤ 50 G
Ambient temp.	-10 to 70 °C, storage: -25 to 85 °C (no freezing or condensation)
Ambient humi.	35 to 85%RH, storage: 35 to 90%RH (no freezing or condensation)
Protection rating	IP50 (IEC standard)
Connection	Axial cable type (cable gland)
Cable spec.	Ø 6 mm, 2 m, shield cable Parallel NPN open collector output: 17-wire × 2, SSI Line driver output: 10-wire
Wire spec.	AWG28 (0.08 mm), insulator diameter: Ø 0.8 mm Parallel NPN open collector output: 17-core, SSI Line driver output: 19-core

Dimensions

- Unit: mm, For the detailed drawings, follow the Autonics website.

■ Parallel NPN open collector output

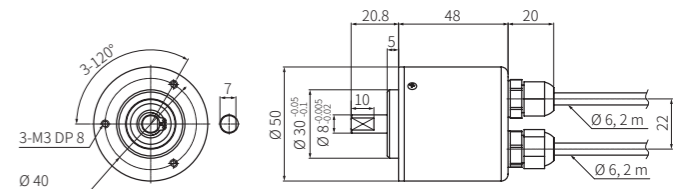

■ SSI Line driver output

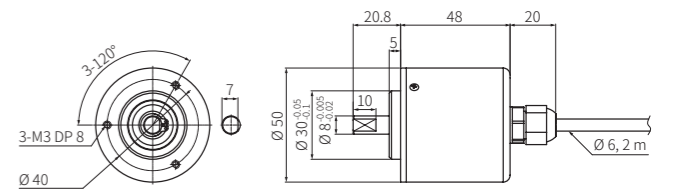

■ Bracket

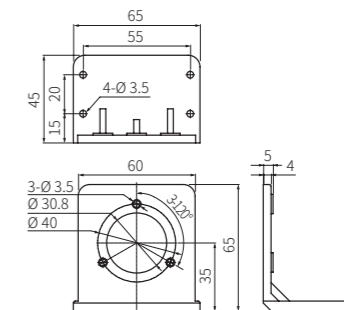

■ Coupling

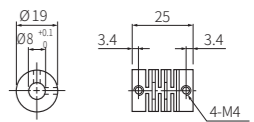

- Parallel misalignment: ≤ 0.25 mm
- Angular misalignment: ≤ 5°
- End-play: ≤ 0.5 mm