

Safety Grip Type Enabling Switches

SFEN Series

INSTRUCTION MANUAL

TCD210234AF

Autonics

Thank you for choosing our Autonics product.

Read and understand the instruction manual and manual thoroughly before using the product.

For your safety, read and follow the below safety considerations before using.

For your safety, read and follow the considerations written in the instruction manual, other manuals and Autonics website.

Keep this instruction manual in a place where you can find easily.

The specifications, dimensions, etc. are subject to change without notice for product improvement. Some models may be discontinued without notice.

Follow Autonics website for the latest information.

Safety Considerations

- Observe all 'Safety Considerations' for safe and proper operation to avoid hazards.
- ⚠ symbol indicates caution due to special circumstances in which hazards may occur.

⚠ Warning Failure to follow instructions may result in serious injury or death.

- Fail-safe device must be installed when using the unit with machinery that may cause serious injury or substantial economic loss.** (e.g. nuclear power control, medical equipment, ships, vehicles, railways, aircraft, combustion apparatus, safety equipment, crime/disaster prevention devices, etc.)
Failure to follow this instruction may result in personal injury, economic loss or fire.
- System manager means followings;**
- a personnel who is fully aware of installation, setting, operation, and maintenance of the product
- a personnel who well observes standard/regulation/statute on the product by type of machine the product installed in and nation/region the product used in
Machine user means a personnel who is appropriately trained about using machine by the system manager, so that machine user can operate the machine correctly.
System manager has duty to train the machine user about operation of the product.
Machine user has to report directly to the system manager when unusual status has been found while system is operating.
Failure to follow this instruction may result in personal injury, economic loss or fire.
- The product has to be installed, set, and combined with machine control system by the qualified system manager.**
Failure to follow this instruction may result in personal injury due to unintended operation and unstable detection.
- Before using the product, check that function of the product operates as intended while machine is turned off after installation.**
Failure to follow this instruction may result in personal injury due to unintended operation and unstable detection.
- This product is a switch used to perform maintenance and repair of machines such as robots in the safe area. Configure the system to operate only in position 2 so that the machine can only be operated when the switch is operated. Also, do not maintain position 2 by any means other than manual manipulation.**
Failure to follow this instruction may result in personal injury due to malfunction of the product and safety function.
- Do not use the unit in the place where flammable/explosive/corrosive gas, high humidity, direct sunlight, radiant heat, vibration, impact, salinity, moisture, steam or dust may be present.**
Failure to follow this instruction may result in explosion or fire.
- Do not connect, repair, inspect, or replace the unit while connected to a power source.**
Failure to follow this instruction may result in personal injury due to malfunction of the product and safety function.
- Do not disassemble or modify the unit.**
Failure to follow this instruction may result in personal injury or fire due to loss of safety function.
- Do not drop or impact the product.**
Failure to follow this instruction may result in personal injury due to continuous machine operation when the product is damaged.
- Do not use the door switch with only the holding key inserted.**
Failure to follow this instruction may result in personal injury after switch is disabled.
- Configure the switches to be inoperable in the status of the enabling switch with the holding key inserted into the door switch.**
- Do not defeat, tamper, modify, or bypass the switch and enter the door.**
Failure to follow this instruction may result in personal injury.
- Check whether machine is stopped or not when the door is opened.**
Failure to follow this instruction may result in personal injury.
- Check the installed status of the switch, operating status of the switch, and signs of damage, modification, tampering of the switch at the following situation and on a weekly basis.**
- when operating the safety system at first
- when replacing component of the system
- when the system has not been operated for a long time
Failure to follow this instruction may result in personal injury due to malfunction of the product and safety function.

⚠ Caution Failure to follow instructions may result in injury or product damage.

- Use the unit within the rated specifications.**
Failure to follow this instruction may result in fire or product damage.
- Keep the product away from metal chip, dust, and wire residue which might flow into the unit.**
Failure to follow this instruction may result in fire, product damage or malfunction.
- Use a dry cloth to clean the unit, and do not use water or organic solvent.**
Failure to follow this instruction may result in fire.
- Do not use the switch as a door lock, guard door stopper or for stopping/starting machinery.**
Failure to follow this instruction may result in product damage.
- When combining the cover, if the rubber packing is twisted, lifted, cracked, broken, or foreign substances are introduced, the sealing properties and operation characteristics may be deteriorated.**
Be careful not to be damaged by sharp objects and use it after confirming that it is properly combined.
- Use only Autonics holding key.**
Failure to follow this instruction may result in product damage.
- Do not apply excessive vibration or shock to the switch in the status of the switch with the holding key inserted into the door switch.**
Failure to follow this instruction may result in product damage or malfunction.
- Do not use metallic cable gland.**
Failure to follow this instruction may result in electric shock due to the damage on the service entrance.
- When the SFEN-B is used alone, it cannot be used as a stop button switch.**
Be sure to use it together with the stop button switch or emergency cut-off switch installed in a fixed position.
Since it is a separately using product, it cannot satisfy the SEM-S2 standard.
- In SFEN-M, when A and B push buttons are pressed at the same time, both contacts are in the ON status.**
Please use it after confirming that there are no safety problems.

Cautions during Use



- Follow instructions in 'Cautions during Use'. Otherwise, it may cause unexpected accidents.
- Use the switch with the dedicated controller. Do not use the switch with another controller randomly.
- Durability of the product can be differed according to opening condition.
Check the environment where the product is used in and machine which the product is used for, and use the product within the rated number of mechanical durability.
- Do not connect a load with a small capacity to the contact point that has opened and closed the load once.
It may cause product malfunction due to the rough contact surface.
- If the contact is not opened and closed for a long time, the contact resistance may increase or conduction failure may occur due to oxidation of the contact surface or etc.
- This product is dedicated for Autonics safety door switch, SFD Series.
Do not use with the door lock switch from other manufacturer.
- To unlock the stop button, turn the button approximately 45°clockwise, and do not turn the button with excessive force.
- Do not hit or flip the switch or button, and use hand not any tool to push the switch or button.
- This unit may be used in the following environments.
 - Indoors (UL Type 1 Enclosure)
 - Altitude max. 2,000 m
 - Pollution degree 3
 - Installation category II

Ordering Information

This is only for reference, the actual product does not support all combinations.
For selecting the specified model, follow the Autonics website.

SFEN - ①

① Type

No mark: Standard type	B: Stop button type	M: Momentary button type
		

Product Components

- Product × 1
- Instruction manual × 1
- Cable gland × 1

Sold Separately

- Mounting bracket: BK-SFEN
- Holding key: SFEN-HK

Specifications

• Enable switch	
Rated Insulation Voltage	250 VAC~
Rated through current	2.5 A
Rated inductive load	AC-15 (0.75 A / 240 VAC~), DC-13 (0.55 A / 125 VDC=)
Rated resistive load^(①)	0.75 A / 240 VAC~, 0.55 A / 125 VDC=
Controller strength^(②)	Operation direction: 200 N, for 1 min
Operating frequency	Electrical: ≤ 20 / min, Mechanical: ≤ 20 / min
Dielectric strength	Between terminals of same polarity, between terminals of different polarity, between terminal and non-live part : 2,500 VAC~ 50 / 60 Hz for 1 min (impulse dielectric strength)
Electrical life cycle	≥ 100,000 operations (rated load)
Mechanical life cycle	OFF → ON → OFF: ≥ 100,000 operations / OFF → ON: ≥ 1,000,000 operations

- Use a 10 A fuse gl or gG conforming to IEC60269 as short-circuit protection. The body does not have a built-in fuse.
- Do not use the switch more than the controller strength. Failure to follow this instruction may result in product damage.

• Stop button

Rated Insulation Voltage	250 VAC~
Rated through current	3 A
Rated resistive load^(①)	AC-12 (3 A / 250 VAC~), DC-12 (3 A / 30 VDC=)
Controller strength^(②)	Operation direction: 400 N, for 1 min (operation direction: 0.5 N m, for 1 min)
Operating frequency	Electrical: ≤ 10 / min, Mechanical: ≤ 10 / min
Dielectric strength	Between terminals of same polarity: 1,000 VAC~ 50 / 60 Hz for 1 min. between terminals of different polarity, between terminal and non-live part : 2,000 VAC~ 50 / 60 Hz for 1 min.
Electrical life cycle	≥ 100,000 operations (rated load) (Push / Release 1 time)
Mechanical life cycle	≥ 100,000 operations (Push / Release 1 time)





- Use a 10 A fuse gl or gG conforming to IEC60269 as short-circuit protection. The body does not have a built-in fuse.
- Do not use the button more than the controller strength. Failure to follow this instruction may result in product damage.

• Momentary button

Rated Insulation Voltage	125 VAC~
Rated through current	0.1 A
Rated resistive load^(①)	AC-12 (0.1 A / 125 VAC~), DC-12 (0.1 A / 30 VDC=)
Controller strength^(②)	Operation direction: 10 N, for 1 min
Operating frequency	Electrical: ≤ 25 / min, Mechanical: ≤ 60 / min
Dielectric strength	Between terminals of same polarity: 600 VAC~ 50 / 60 Hz for 1 min. between terminals of different polarity, between terminal and non-live part : 1,000 VAC~ 50 / 60 Hz for 1 min.
Electrical life cycle	≥ 100,000 operations (rated load)
Mechanical life cycle	≥ 1,000,000 operations

- Use a 10 A fuse gl or gG conforming to IEC60269 as short-circuit protection. The body does not have a built-in fuse.
- Do not use the button more than the controller strength. Failure to follow this instruction may result in product damage.

■ Common spec.

Conditional short circuit current	100 A
Min. applied load	DC24 V 4 mA
Directing opening force	30 N ± 10
Directing opening distance	4.8 mm ± 0.5
Insulation resistance	≥ 100 MΩ (500 VDC= megger)
Vibration (malfunction)	1.5 mm double amplitude at frequency of 10 to 55 Hz in each X, Y, Z direction for 10 min
Shock (malfunction)	150 m/s ² (≈ 15 G) in each X, Y, Z direction for 3 times
Ambient temperature	-10 to 55 °C, storage: -25 to 65 °C (no freezing or condensation)
Ambient humidity	35 to 85 %RH, storage: 35 to 85 %RH (no freezing or condensation)
Insulation class	Class II (double insulation)
Indicator	Enable operation indicator (green)
Protection structure	SFEN: IP66 (IEC standard) SFEN-B, SFEN-M: IP65 (IEC standard)
Applicable wire	AWG 20 to 18 (0.5 to 0.75 mm ²)
Connection type	M20 connector cable gland
Material	Cover: PA66, button: PC, rubber grip: Silicone
International standards	IEC 60947-5-1, IEC 60947-5-8, UL 60947-5-1
Approval	CE (TUV NORD)    
Unit weight (package)	SFEN: ≈ 238 g (≈ 363 g) SFEN-B: ≈ 268 g (≈ 388 g) SFEN-M: ≈ 252 g (≈ 376 g)

■ Contact composition

	SFEN	SFEN-B	SFEN-M
Enable switch	2 N.O.	2 N.O.	2 N.O.
Option output	1 N.C.	-	-
Stop button	-	2 N.C.	-
Momentary button	-	-	2 N.O.

Connections

- Tighten the bolt with the designated tightening torque of each, using spring washer/flat washer. Failure to follow this instruction may result in product failure or damage. Below tightening torque is for the status of installing with spring washer / flat washer.

Screw	Tightening torque
Front cover screw (M3)	0.7 to 0.9 N m
Cable gland	2.7 to 3.0 N m
Terminal screw	0.5 to 0.6 N m

- When wiring with the ring crimp terminal, connect the terminals as shown in figure for the cable not to override to the case and cover.
- Use lead wire sizes AWG 20 to 18 (0.5 to 0.75 mm²) and prepare lead wires using the length given in the following diagram. If lead wires are too long or short, the cover may not be properly closed.

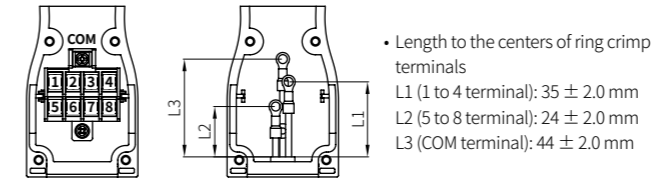

- Use the UL approved ring crimp terminal listed in below

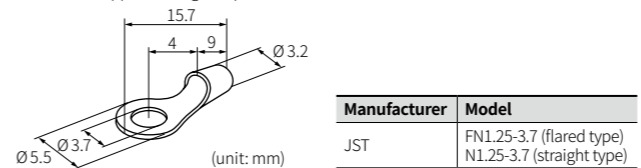

Enable Operation Indicator

- The figure below shows wiring when using the enable operation indicator. Connect the other terminals correctly for the desired usage. For more information, refer to the wiring.
- When connecting a load to the product, the load must be connected to the terminal 3.
- Supply more than 24 VAC~ / VDC= when using enable operation indicator.

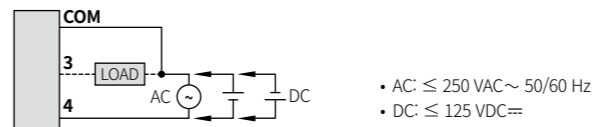

Operation Pattern

- Use the product by grasping as shown in the picture.

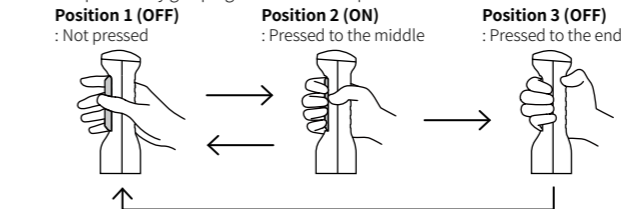

- There is no simultaneity of the contact action characteristics, and a time difference may occur in some sections.
- ⊕ Direct opening action possible
- Direct opening: Occurs when operating position 2 (closed) to position 3 (open).
- ⊖ Contact ON (closed) / □ Contact OFF (open)

■ SFEN

Terminal number	Position 1	Position 2	Position3
1 - 2	⊖	⊕	⊖
3 - 4	⊖	⊕	⊖
Option output	⊖	⊕	⊖

■ SFEN-B

Terminal number	Position 1	Position 2	Position3
1 - 2	⊖	⊕	⊖
3 - 4	⊖	⊕	⊖
Option output	⊖	⊕	⊖

Terminal number	Operation	Contact
5 - 6	Push	ON → OFF
7 - 8	Release	OFF → ON

■ SFEN-M

Even when pushbuttons A and B are pressed simultaneously, the contact turns ON. Pay attention to safety.

Terminal number	Position 1	Position 2	Position3
1 - 2	⊖	⊕	⊖
3 - 4	⊖	⊕	⊖
Option output	⊖	⊕	⊖

Terminal number	Operation	Contact
5 - 6	Push button A	OFF → ON
7 - 8	Push button B	OFF → ON

Dimensions

- Unit: mm, For the detailed drawings, follow the Autonics website.

A	Enable operation indicator (green)	B	Cable gland
C	Push button B	D	Push button A

■ SFEN

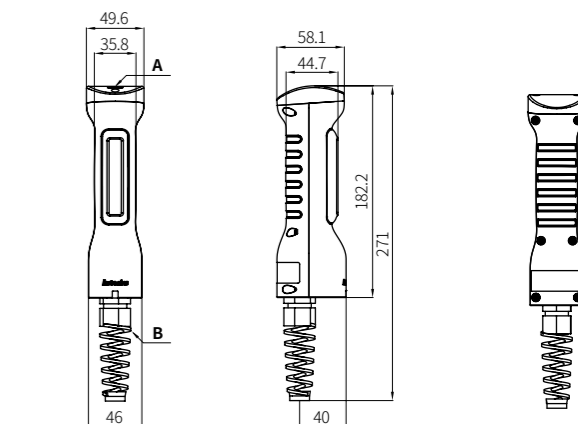

■ SFEN-B

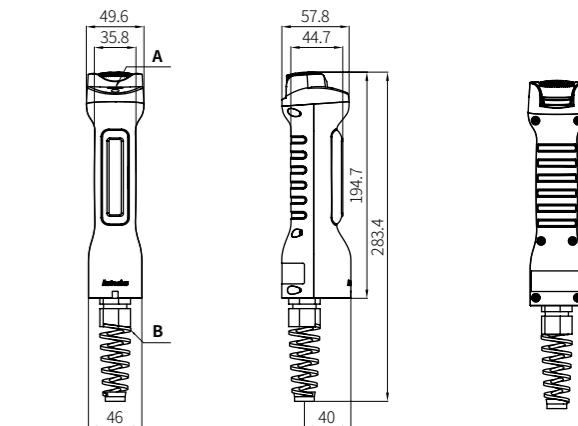

■ SFEN-M

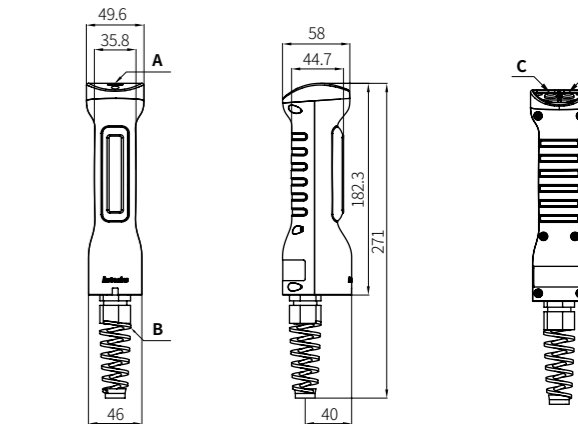

Connecting Cable Gland

- When tightening or replacing the cable gland, assemble the seal nut part and then the flexible nut part in order.

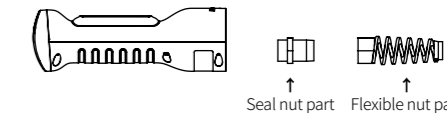

- Cable gland specification and recommended product

Manufacturer	Model	Cable Ø
LAPP	SKINTOP BS ISO M20×1.5 RAL 9005 BK / 5311-1720	7 - 13 mm