

FM Series

INSTRUCTION MANUAL

TCD230040AB



Thank you for choosing our Autonics product.

Read and understand the instruction manual and manual thoroughly before using the product.

For your safety, read and follow the below safety considerations before using.

For your safety, read and follow the considerations written in the instruction manual, other manuals and Autonics website.

Keep this instruction manual in a place where you can find easily.

The specifications, dimensions, etc. are subject to change without notice for product improvement. Some models may be discontinued without notice.

Follow Autonics website for the latest information.

Safety Considerations

- Observe all 'Safety Considerations' for safe and proper operation to avoid hazards.
- ⚠ symbol indicates caution due to special circumstances in which hazards may occur.

⚠ Warning Failure to follow instructions may result in serious injury or death.

01. Fail-safe device must be installed when using the unit with machinery that may cause serious injury or substantial economic loss. (e.g. nuclear power control, medical equipment, ships, vehicles, railways, aircraft, combustion apparatus, safety equipment, crime / disaster prevention devices, etc.)
Failure to follow this instruction may result in personal injury, economic loss or fire.

02. Do not use the unit in the place where flammable / explosive / corrosive gas, humidity, direct sunlight, radiant heat, vibration, impact, or salinity may be present.
Failure to follow this instruction may result in explosion or fire.

03. Install on a device panel to use.
Failure to follow this instruction may result in fire or electric shock.

04. Do not connect, repair, or inspect the unit while connected to a power source.
Failure to follow this instruction may result in fire or electric shock.

05. Check 'Connections' before wiring.
Failure to follow this instruction may result in fire.

06. Do not disassemble or modify the unit.
Failure to follow this instruction may result in fire or electric shock.

⚠ Caution Failure to follow instructions may result in injury or product damage.

01. When connecting the power / sensor input and relay output, use AWG 20 (0.50 mm²) cable or over, and tighten the terminal screw with a tightening torque of 0.74 to 0.90 N m.
Failure to follow this instruction may result in fire or malfunction due to contact failure.

02. Use the unit within the rated specifications.
Failure to follow this instruction may result in fire or product damage.

03. Use a dry cloth to clean the unit, and do not use water or organic solvent.
Failure to follow this instruction may result in fire or electric shock.

04. Keep the product away from metal chip, dust, and wire residue which flow into the unit.
Failure to follow this instruction may result in fire or product damage.

Cautions during Use

- Follow instructions in 'Cautions during Use'. Otherwise, it may cause unexpected accidents.
- Use the product, 0.1 sec after supplying power.
- When supplying or turning off the power, use a switch or etc. to avoid chattering.
- Install a power switch or circuit breaker in the easily accessible place for supplying or disconnecting the power.
- When the counter is operating, in case of contact input, set count speed to low speed mode (1 cps or 30 cps) to operate. If set to high speed mode (300, 2 k, 5 kcps) counting error occurs due to chattering.
- Keep away from high voltage lines or power lines to prevent inductive noise. In case installing power line and input signal line closely, use line filter or varistor at power line and shielded wire at input signal line. Do not use near the equipment which generates strong magnetic force or high frequency noise.
- This unit may be used in the following environments.
 - Indoors (in the environment condition rated in 'Specifications')
 - Altitude max. 2,000 m
 - Pollution degree 2
 - Installation category II

Ordering Information

This is only for reference, the actual product does not support all combinations. For selecting the specified model, follow the Autonics website.

FM ① ② - ③ ④

① Display digits

4: 4-digit
6: 6-digit

② Function

M: Measure function

③ Output

1P: 1-stage setting
2P: 2-stage setting
I: Indicator

④ Power supply

4: 100 - 240 VAC

Product Components

- Product (+ bracket)
- Instruction manual

Sold Separately

- Terminal protection cover: RMA-COVER

Dimensions

- Unit: mm, For the detailed drawings, follow the Autonics website.

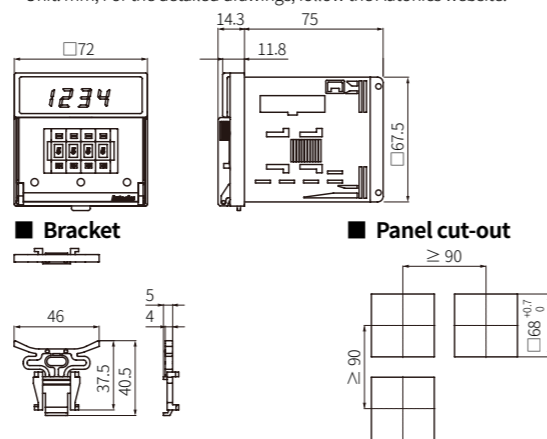

Connections

■ 2-stage setting model

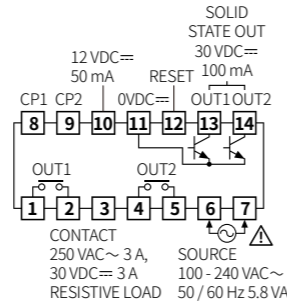

■ 1-stage setting model

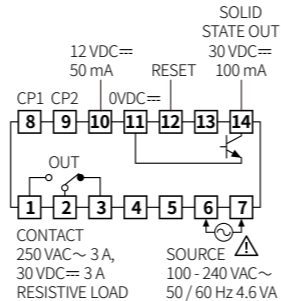

■ Indicator model

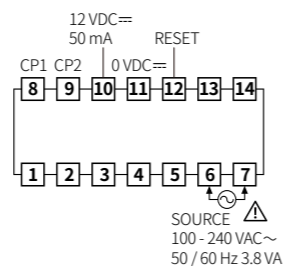

Specifications

Model	FM4M-□4	FM6M-□4
Display digits	4-digit	6-digit
Character size	W 6 × H 10 mm	W 4 × H 8 mm
Max. counting speed	1 / 30 / 300 / 2 k / 5 k cps	
Return time	≤ 500 ms	
Min. signal width	RESET: ≈ 20 ms	
Input logic	Voltage input (PNP) - input impedance: ≤ 10.8 kΩ, [H]: 5 - 30 VDC, [L]: 0 - 2 VDC No-voltage input (NPN) - short-circuit impedance: ≤ 470 Ω, short-circuit residual voltage: ≤ 1 VDC, open-circuit impedance: ≥ 100 kΩ	
One-shot output time	0.01 to 99.99 s	
Contact control output	Relay	
Type (1-stage)	Instantaneous SPDT (1c) × 1	
Type (2-stage)	Instantaneous SPST (1a) × 2	
Capacity	250 VAC ~ 3 A, 30 VDC = 3 A resistive load	
Solid-state control output	NPN open collector	
Type (1-stage)	× 1	
Type (2-stage)	× 2	
Capacity	≤ 30 VDC, 100 mA, residual voltage: ≤ 1 VDC	
Unit weight (packaged)	1-stage setting: ≈ 180 g (≈ 245 g) 2-stage setting: ≈ 200 g (≈ 265 g) Indicator: ≈ 160 g (≈ 225 g)	
Certification	CE, RoHS, ENEC	

Power supply	100 - 240 VAC ~ 50 / 60 Hz
Permissible voltage range	90 to 110 % of rated voltage
Power consumption	Dependent on the output
1-stage setting	≤ 4.6 VA
2-stage setting	≤ 5.8 VA
Indicator	≤ 3.8 VA
External supply power	≤ 12 VDC, ± 10 % 50 mA
Memory retention	≈ 10 years (non-volatile semiconductor memory type)
Insulation resistance	≥ 100 MΩ (500 VDC, megger)
Dielectric strength	Between the charging part and the case : 3,000 VAC ~ 50 / 60 Hz for 1 min
Noise immunity	± 2 kV square wave noise (pulse width: 1 μs) by the noise simulator
Vibration	0.75 mm double amplitude at frequency of 10 to 55 Hz in each X, Y, Z direction for 1 hour
Vibration (malfunction)	0.5 mm double amplitude at frequency of 10 to 55 Hz in each X, Y, Z direction for 10 minute
Shock	300 m/s ² (≈ 30 G) in each X, Y, Z direction for 3 times
Shock (malfunction)	100 m/s ² (≈ 10 G) in each X, Y, Z direction for 3 times
Relay life cycle	Mechanical: ≥ 5,000,000 operations Electrical: ≥ 100,000 operations (250 VAC ~ 3 A resistive load)
Ambient temperature	-10 to 55 °C, storage: -25 to 65 °C (no freezing or condensation)
Ambient humidity	35 to 85 %RH, storage: 35 to 85 %RH (no freezing or condensation)
Protection rating	IP20 (front part, IEC standard)

Error

- When error occurs, the output turns OFF.
- When 1-stage setting value = 0, OUT1 turns OFF.
- When 2-stage setting value < 1-stage setting value, OUT1 is ignored and only OUT2 operates.
- Indicator model does not have error display function.

Display	Description	Troubleshooting
Error	Setting value = 0	Change the setting value anything but 0.

Mode Setting

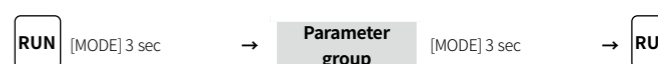

Parameter Setting

- Some parameters are activated / deactivated depending on the model or setting of other parameters. Refer to the description of each parameter.
- Parameter name and setting value are cross-displayed on the display part.
- If any key is not entered for 60 sec in each parameter, it returns to RUN mode.
- [MODE] key: Saves current setting value and moves to the next parameter.
- [◀] key: Checks fixed value / Changes setting digits.
- [▶] key: Changes setting values.

Parameter	Display	Defaults	Setting range	Display condition
1-1 Input operation mode	I n	U d - P	UD-A: command input, UD-B: individual input, UD-C: phase difference input, UP: count up input, UD-D: command input, UD-E: individual input, UD-F: phase difference input, DN: count down input	-
1-2 Output operation mode	o U t . n	F	[1-stage / 2-stage setting model] F, N, C, R, K, P, Q, S	-
1-3 Max. counting speed	∫ P S	30	30, 300, 2K, 5K, 1 cps	-
1-4 OUT2 output time ⁽⁰¹⁾	o U t 2	H o l d	[2-stage setting model] Hold	1-2 Output operation mode: C, R, K, P, Q 1-2 Output operation mode: F, N, S
1-5 OUT1 output time ⁽⁰¹⁾	o U t 1	H o l d	[2-stage setting model] Hold, 00.01 to 99.99 sec	1-2 Output operation mode: except S
1-6 Decimal point position ⁽⁰²⁾	d P	- - - -	[4-digit model] ---, ---, ---, --- [6-digit model] ---, ---, ---, ---, ---, ---	-
1-7 Input logic	S i G	P n P	PNP, NPN	-
1-8 Mode setting	n - d	n U L t	MULT: multiply mode, DIV: divide mode	-
1-9 Multiply mode	n U L t	-	• Display value = input signal × setting value for multiply mode	1-8 Mode setting: MULT
1-10 Decimal point position for prescale ⁽⁰²⁾	S C d P	- - - -	[4-digit model] ---, ---, ---, --- [6-digit model] ---, ---, ---, ---, ---, ---	
1-11 Setting value for multiply mode ⁽⁰²⁾	n S C L	1 0 0 0	[4-digit model] 0.001 to 9999 [6-digit model] 0.001 to 999999	
1-12 Divide mode	d i v	-	• Display value = input signal / setting value for multiply mode	1-8 Mode setting: DIV
1-13 Setting value for divide mode	d S u	0 0 0 1	[4-digit model] 1 to 9999 [6-digit model] 1 to 999999	
1-14 Memory retention	d R t R	r e c	REC: Memorizes counting value at the moment of power off. (memory retention) CLR: Resets counting value when power is off.	-
1-15 Front [RESET] key	r 5 t . b	o n	ON: Use, OFF: Not used	-

01) In case of 1-stage setting model, 1-5 OUT1 output time is not displayed, 1-4 OUT2 output time is displayed as OUTT.
02) Decimal point position for prescale and setting value for multiply mode are variable according to decimal point position.

Decimal point position	Decimal point position for prescale	Setting value for multiply mode
- - - -	---, ---, ---, ---	0.001 ~ 9999
- - - .	---, ---, ---, ---	0.001 ~ 999.9
- - . -	---, ---, ---, ---	0.001 ~ 99.99
- . - -	---, ---, ---, ---	0.001 ~ 9.999
[6-digit model]		
- - - -	---, ---, ---, ---	0.001 ~ 999999
- - - .	---, ---, ---, ---	0.001 ~ 99999.9
- - . -	---, ---, ---, ---	0.001 ~ 9999.99
- . - -	---, ---, ---, ---	0.001 ~ 999.999

Output Operation Mode

For the detailed timing chart for operation output mode, refer to the manual.