

W 48 × H 48 mm Analog Timers

ATN Series

INSTRUCTION MANUAL

TCD220046AC

Autonics

Thank you for choosing our Autonics product.

Read and understand the instruction manual and manual thoroughly before using the product.

For your safety, read and follow the below safety considerations before using.

For your safety, read and follow the considerations written in the instruction manual, other manuals and Autonics website.

Keep this instruction manual in a place where you can find easily.

The specifications, dimensions, etc. are subject to change without notice for product improvement. Some models may be discontinued without notice.

Follow Autonics website for the latest information.

Safety Considerations

- Observe all 'Safety Considerations' for safe and proper operation to avoid hazards.
- ⚠ symbol indicates caution due to special circumstances in which hazards may occur.

⚠ Warning Failure to follow instructions may result in serious injury or death.

01. Fail-safe device must be installed when using the unit with machinery that may cause serious injury or substantial economic loss. (e.g. nuclear power control, medical equipment, ships, vehicles, railways, aircraft, combustion apparatus, safety equipment, crime/disaster prevention devices, etc.)
Failure to follow this instruction may result in personal injury, economic loss or fire.

02. Do not use the unit in the place where flammable/explosive/corrosive gas, high humidity, direct sunlight, radiant heat, vibration, impact or salinity may be present.
Failure to follow this instruction may result in explosion or fire.

03. Install on a device panel to use.

Failure to follow this instruction may result in fire or electric shock.

04. Do not connect, repair, or inspect the unit while connected to a power source.

Failure to follow this instruction may result in fire or electric shock.

05. Check 'Connections' before wiring.

Failure to follow this instruction may result in fire.

06. Do not disassemble or modify the unit.

Failure to follow this instruction may result in fire or electric shock.

⚠ Caution Failure to follow instructions may result in injury or product damage.

01. Use the unit within the rated specifications.

Failure to follow this instruction may result in fire or product damage.

02. Use a dry cloth to clean the unit, and do not use water or organic solvent.

Failure to follow this instruction may result in fire or electric shock.

03. Keep the product away from metal chip, dust, and wire residue which flow into the unit.

Failure to follow this instruction may result in fire or product damage.

Cautions during Use

- Follow instructions in 'Cautions during Use'. Otherwise, it may cause unexpected accidents.
- Power supply should be insulated and limited voltage/current or Class2, SELV power supply device.
- When supplying or turning off the power, use a switch or etc. to avoid chattering.
- Install a power switch or circuit breaker in the easily accessible place for supplying or disconnecting the power.
- In order to block peripheral current, use isolation transformer which of secondary part is not grounded to supply power to the external input device.

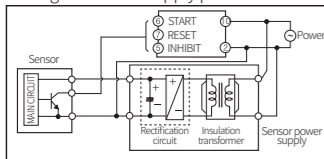

- In order to avoid leakage current flowing, connect resistance and condenser like below. Otherwise, it may cause malfunction.

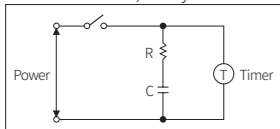

- Do not connect two or more timers with only one input contact or transistor simultaneously.
- After turning off the power, change the time range, etc.
- Keep away from high voltage lines or power lines to prevent inductive noise. In case installing power line and input signal line closely, use line filter or varistor at power line and shielded wire at input signal line.
- Do not use near the equipment which generates strong magnetic force or high frequency noise.
- This unit may be used in the following environments.
 - Indoors (in the environment condition rated in 'Specifications')
 - Altitude max. 2,000 m
 - Pollution degree 2
 - Installation category II

Ordering Information

This is only for reference, the actual product does not support all combinations. For selecting the specified model, follow the Autonics website.

AT ① ② N - ③

① Plug type

- 8: 8-pin plug
- 11: 11-pin plug

② Power supply

- No mark: 100 - 240 VAC 50 / 60 Hz, 24 - 240 VDC
- 1: 12 VDC
- 2: 24 VAC 50 / 60 Hz, 24 VDC

③ Output

- No mark: Time limit DPDT (2c), Instantaneous SPDT (1c) + Time limit SPDT (1c)
- D: Time limit DPDT (2c)
- E: Instantaneous SPDT (1c) + Time limit SPDT (1c)

Product Components

- Product (+ bracket)
- Instruction manual

Sold Separately

- 8-pin controller socket: PG-08, PS-08(N)
- 11-pin controller socket: PG-11, PS-11(N)

Dimensions

- Unit: mm, For the detailed drawings, follow the Autonics website.

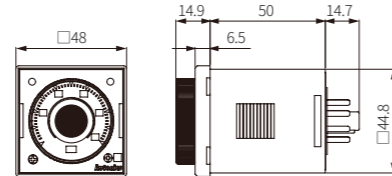

■ Bracket

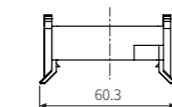
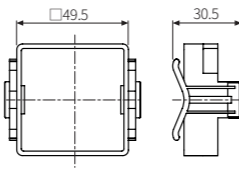

■ Panel cut-out

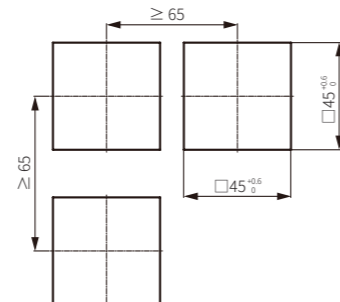

Unit Descriptions

No.	Name
1	Power indicator
2	Time limit output indicator
3	Time range display part
4	Time range setting switch
5	Time unit display part
6	Output operation mode setting switch
7	Output operation mode display part
8	Dial for the time setting

Output Operation Mode

For the detailed timing chart for operation output mode, refer to the manual. The output operation mode differs depending on each model.

■ AT8N

Display part	Output operation mode
A	Power ON Delay
A1	Power ON Delay1 (One-shot output)
B	Power ON Delay2
F	Flicker (OFF Start)
F1	Flicker1 (ON Start)
I	Interval

■ AT11□N

Display part	Output operation mode
A	Signal ON Delay
F	Flicker (OFF Start)
F1	Flicker1 (ON Start)
C	Signal OFF Delay
D	Signal ON/OFF Delay
I	Interval

Time Range

The unit of time range follows the time unit display part (sec, min, hrs). If the display part is set 10h, the unit of the time range is the hour.

Display	Range	Unit
0.5	0.05 to 0.5	sec / min / hrs
1	0.1 to 1	
5	0.5 to 5	
10	1 to 10	

Display	Range	Unit
0.5	0.5 to 5	10h
1	1 to 10	
5	5 to 50	
10	10 to 100	

Connections

⚠ Caution

- Refer to the 'specifications' for checking the power supply and control output.
- The AT11□N model: Be sure to use terminal No. 2 as the common terminal to connect terminals No. 5, 6, and 7.
Failure to follow this instruction may result in product malfunction.

■ AT8N

- Output operation mode: A, F

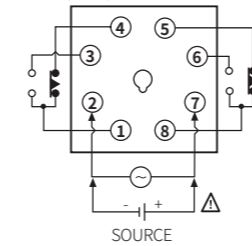

- Output operation mode: A1, B, F1, I

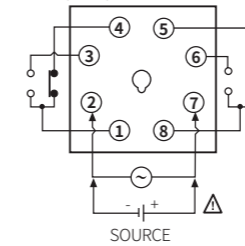

■ AT11DN

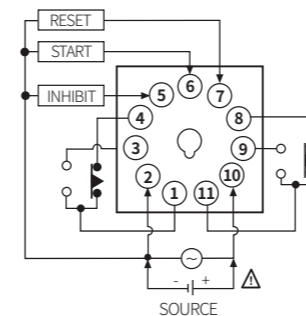

■ AT11EN

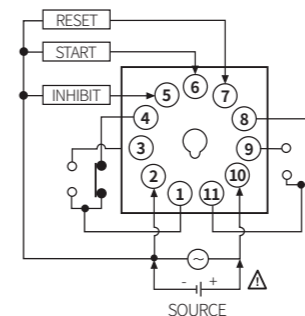

Specifications

Model	AT8N-□	AT11DN-□	AT11EN-□
Function	Multi Function Timer		
Return time	≤ 100 ms		
Time operation	Power ON Start	Signal ON Start	
Input	-	INHIBIT, START, RESET	
Min. signal width	-	≈ 50 ms	
No-voltage input	-	Short-circuit impedance: ≤ 1 kΩ Short-circuit residual voltage: ≤ 0.5 VDC Open-circuit impedance: ≥ 100 kΩ	
Control output	Relay		
Contact type	Time limit DPDT (2c), Time limit SPDT (1c) + Instantaneous SPDT (1c)	Time limit DPDT (2c)	Time limit SPDT (1c) + Instantaneous SPDT (1c)
Contact capacity	250 VAC~ 5 A, 30 VDC= 5 A resistive load	250 VAC~ 5 A, 24 VDC= 5 A resistive load	250 VAC~ 5 A, 30 VDC= 5 A resistive load
Error	Repeat: ≤ ± 0.2% ± 10 ms SET: ≤ ± 5% ± 50 ms Voltage: ≤ ± 0.5% Temp.: ≤ ± 2%		
Certification	CE, RoHS, ENEC, ETL		
Unit weight (packaged)	≈ 86.71 g (≈ 134.12 g)	≈ 85 g (≈ 132.2 g)	≈ 87.5 g (≈ 134.7 g)

Power supply	100 - 240 VAC~ 50 / 60 Hz, 24 - 240 VDC=	12 VDC=	24 VAC~ 50 / 60 Hz, 24 VDC=
Permissible voltage range	90 to 110 % of rated voltage		
Power consumption	It depends on the model.		
AT8N-□	AC: ≤ 4.3 VA DC: ≤ 2 W	DC: ≤ 1.5 W	AC: ≤ 4.5 VA DC: ≤ 2 W
AT11DN-□	AC: ≤ 3.5 VA DC: ≤ 1.5 W	DC: ≤ 1 W	AC: ≤ 4 VA DC: ≤ 1.5 W
AT11EN-□	AC: ≤ 4.3 VA DC: ≤ 2 W	DC: ≤ 1.5 W	AC: ≤ 4.5 VA DC: ≤ 2 W
Insulation resistive	≥ 100 MΩ (500 VDC= megger)		
Dielectric strength	Between the charging part and the case : 3,000 VAC~ at 50 / 60 Hz for 1 min		
Noise immunity	± 2 kV square-wave noise by noise simulator (pulse width 1 μs)	± 500 V square-wave noise by noise simulator (pulse width 1 μs)	
Vibration	0.75 mm double amplitude at frequency of 10 to 55 Hz in each X, Y, Z direction for 1 hour		
Vibration (malfunction)	0.5 mm double amplitude at frequency of 10 to 55 Hz in each X, Y, Z direction for 10 min		
Shock	300 m/s² (≈ 30 G) in each X, Y, Z direction for 3 times		
Shock (malfunction)	100 m/s² (≈ 30 G) in each X, Y, Z direction for 3 times		
Relay life cycle	Mechanical: ≥ 10,000,000 operations Electrical: ≥ 100,000 operations (250 VAC~ 5 A resistive load)		
Ambient temperature	-10 to 55 °C, storage: -25 to 65 °C (no freezing or condensation)		
Ambient humidity	35 to 85%RH, storage: 35 to 85%RH (no freezing or condensation)		

■ Contact capacity

- IEC (EN60947-5-1)

Model	AT8N-□	AT11DN-□	AT11EN-□
Rated current	5 A	5 A	5 A
Rated voltage	30 V	250 V	24 V
AC Resistive load (AC-12)	-	5 A	-
DC Resistive load (DC-12)	5 A	-	5 A