

Autonics PULSE METER MP5S/Y/W SERIES INSTRUCTION MANUAL



MP5S MP5Y MP5W
Thank you for choosing our Autonics product.
Please read the following safety considerations before use.

Safety Considerations

※Please observe all safety considerations for safe and proper product operation to avoid hazards.

※Safety considerations are categorized as follows.

Warning Failure to follow these instructions may result in serious injury or death.

Caution Failure to follow these instructions may result in personal injury or product damage.

※The symbols used on the product and instruction manual represent the following

△ symbol represents caution due to special circumstances in which hazards may occur.

Warning

- Fail-safe device must be installed when using the unit with machinery that may cause serious injury or substantial economic loss.** (e.g. nuclear power control, medical equipment, ships, vehicles, railways, aircraft, combustion apparatus, safety equipment, crime/disaster prevention devices, etc.)
Failure to follow this instruction may result in fire, personal injury, or economic loss.
- Install on a device panel to use.**
Failure to follow this instruction may result in electric shock or fire
- Do not connect, repair, or inspect the unit while connected to a power source.**
Failure to follow this instruction may result in electric shock or fire.
- Check 'Connections' before wiring.**
Failure to follow this instruction may result in fire.
- Do not disassemble or modify the unit.**
Failure to follow this instruction may result in electric shock or fire.

Caution

- When connecting the power/measurement input and relay output, use AWG 24(0.20mm²) to AWG 15(1.65mm²) cable and tighten the terminal screw with a tightening torque of 0.98 to 1.18N·m. Use proper cables for the rated load current.**
Failure to follow this instruction may result in fire or malfunction due to contact failure.
- Use the unit within the rated specifications.**
Failure to follow this instruction may result in fire or product damage.
- Use dry cloth to clean the unit, and do not use water or organic solvent.**
Failure to follow this instruction may result in electric shock or fire.
- Do not use the unit in the place where flammable/explosive/corrosive gas, humidity, direct sunlight, radiant heat, vibration, impact, or salinity may be present.**
Failure to follow this instruction may result in fire or explosion.
- Keep metal chip, dust, and wire residue from flowing into the unit.**
Failure to follow this instruction may result in fire or product damage.

Ordering Information

MP	5	Y	-	4	N
Item	Size	Power supply	Output	Digits	
	S	2	S	5	MP
	Y	4	N	9	
	W		1		
			2		
			3		
			4		
			5		
			6		
			7		
			8		
			9		
			10		
			11		
			12		
			13		
			14		
			15		
			16		
			17		
			18		
			19		
			20		
			21		
			22		
			23		
			24		
			25		
			26		
			27		
			28		
			29		
			30		
			31		
			32		
			33		
			34		
			35		
			36		
			37		
			38		
			39		
			40		
			41		
			42		
			43		
			44		
			45		
			46		
			47		
			48		
			49		
			50		
			51		
			52		
			53		
			54		
			55		
			56		
			57		
			58		
			59		
			60		
			61		
			62		
			63		
			64		
			65		
			66		
			67		
			68		
			69		
			70		
			71		
			72		
			73		
			74		
			75		
			76		
			77		
			78		
			79		
			80		
			81		
			82		
			83		
			84		
			85		
			86		
			87		
			88		
			89		
			90		
			91		
			92		
			93		
			94		
			95		
			96		
			97		
			98		
			99		
			100		

※The above specifications are subject to change and some models may be discontinued without notice.
※Be sure to follow cautions written in the instruction manual and the technical descriptions (catalog, homepage).

Specifications

Series	MP5S	MP5Y	MP5W
Display method	7-segment LED (zero blanking method)		
Character size	W4×H8mm	W7×H14mm	
Display range	-19999 to 99999		
Power supply	AC/DC voltage 24VAC~50/60Hz, 24-48VDC		
Power consumption	AC voltage Max. 7.5VA (100-240VAC~50/60Hz)	Max. 9VA (100-240VAC~50/60Hz)	Max. 15VA (100-240VAC~50/60Hz)
Permissible voltage range	90 to 110% of rated voltage		
External power supply	Max. 12VDC ±10% 80mA		
Sub power supply	Max. 24VDC = 30mA		
Input frequency	Solid state input 1: Max. 50kHz (pulse width: min. 10μs) Solid state input 2: Max. 5kHz (pulse width: min. 100μs) ※For F7, F8, F9, F10 operation mode, max. 1kHz (pulse width: min. 500μs) Contact input: Max. 45Hz (pulse width: min. 11ms)		
Input method	[Voltage input] High: 4.5-24VDC, Low: 0-1VDC, Input impedance: 3.9kΩ [No-voltage input] Short-circuit impedance: Max. 80Ω, Residual voltage: Max. 1VDC, Open-circuit impedance: Min. 100kΩ		
Measurement range	Operation mode F1, F2, F7, F8, F9, F10 : 0.0005Hz to 50kHz Operation mode F3, F4, F5, F6 : 0.01 to max. of each time range Operation mode F11, F12, F13, F16 : 0 to 99999 Operation mode F14, F15 : -19999 to 99999		
Measurement accuracy (23°C±5°C)	Operation mode F1, F2, F7, F8, F9, F10 : F.S.±0.05%rdg±1-digit Operation mode F3, F4, F5, F6 : F.S.±0.01%rdg±1-digit		
Display cycle	OFF (for F2, F16 operation mode), 0.05, 0.5, 1, 2, 4, 8 sec (same as update output cycle)		
Operation mode	Frequency/Revolutions/Speed (F1), Passing speed (F2), Cycle (F3), Passing time (F4), Time interval (F5), Time differential (F6), Absolute ratio (F7), Error ratio (F8), Density (F9), Error (F10), Length measurement 1 (F11), Interval (F12), Accumulation (F13), Addition/Subtraction-individual input (F14), Addition/Subtraction-phase difference input (F15), Length measurement 2 (F16)		
Prescale function	Direct input method (0.0001×10 ⁹ to 9.9999×10 ⁹)		
Hysteresis	0 to 9999 ^{※1}		
Output	Main	Sub	
Relay triple	250VAC~3A resistive load		
Relay quintuple	250VAC~3A resistive load		
NPN/PNP open collector quintuple	Max. 30VDC = 30mA		
BCD dynamic	Max. 30VDC = 30mA		
PV transmission	DC4-20mA/DC0-20mA max. load 500Ω		
Communication	RS485 communication output (Modbus RTU method)		
Memory retention	Non-volatile memory (number of inputs: 100,000 operations)		
Insulation resistance	Over 100MΩ (at 500VDC megger)		
Dielectric strength	2,000VAC 60Hz for 1 min		
Noise immunity	±2kV the square wave noise (pulse width: 1μs) by the noise simulator		
Vibration	Mechanical 0.75mm amplitude at frequency of 10 to 55Hz in each X, Y, Z direction for 1 hour Malfunction 0.5mm amplitude at frequency of 10 to 55Hz in each X, Y, Z direction for 10 min		
Shock	Mechanical 300m/s ² (approx. 30G) in each X, Y, Z direction for 3 times Malfunction 100m/s ² (approx. 30G) in each X, Y, Z direction for 3 times		
Relay life cycle	Mechanical	Electrical	
	Min. 10,000,000 operations	Min. 100,000 operations (250VAC 3A resistive load)	
Environment	Ambient temp. -10 to 50°C, storage: -20 to 60°C Ambient humi. 35 to 85%RH, storage: 35 to 85%RH		
Approval	CE, UL, etc.		
Weight ^{※2}	Approx. 191g (approx. 132g) / Approx. 230g (approx. 140g) / Approx. 334g (approx. 210g)		

※1: Setting range will vary depending on the decimal point.
※2: The weight includes packaging. The weight in parenthesis is for unit only.
※Environment resistance is rated at no freezing or condensation.

Dimensions

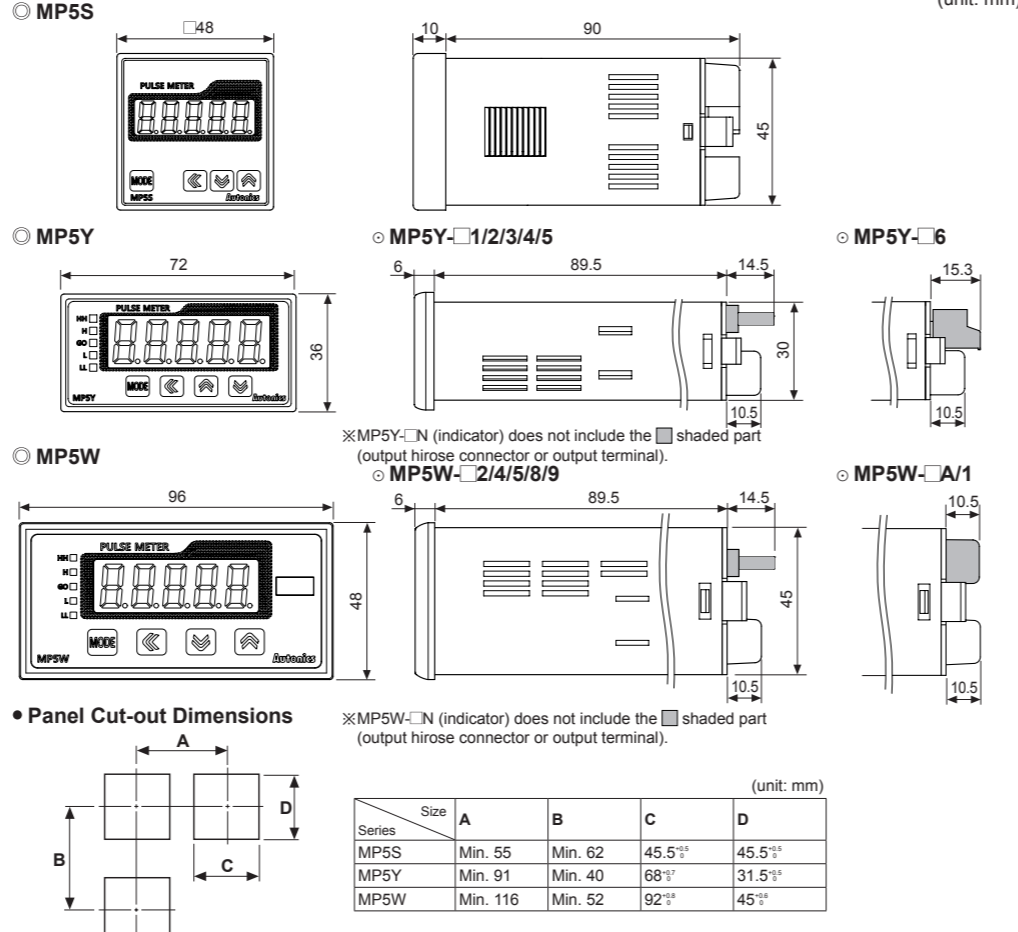

Connections

※Terminal connections differ by power supply and output type of each series and model.
※Use terminals of size specified below.

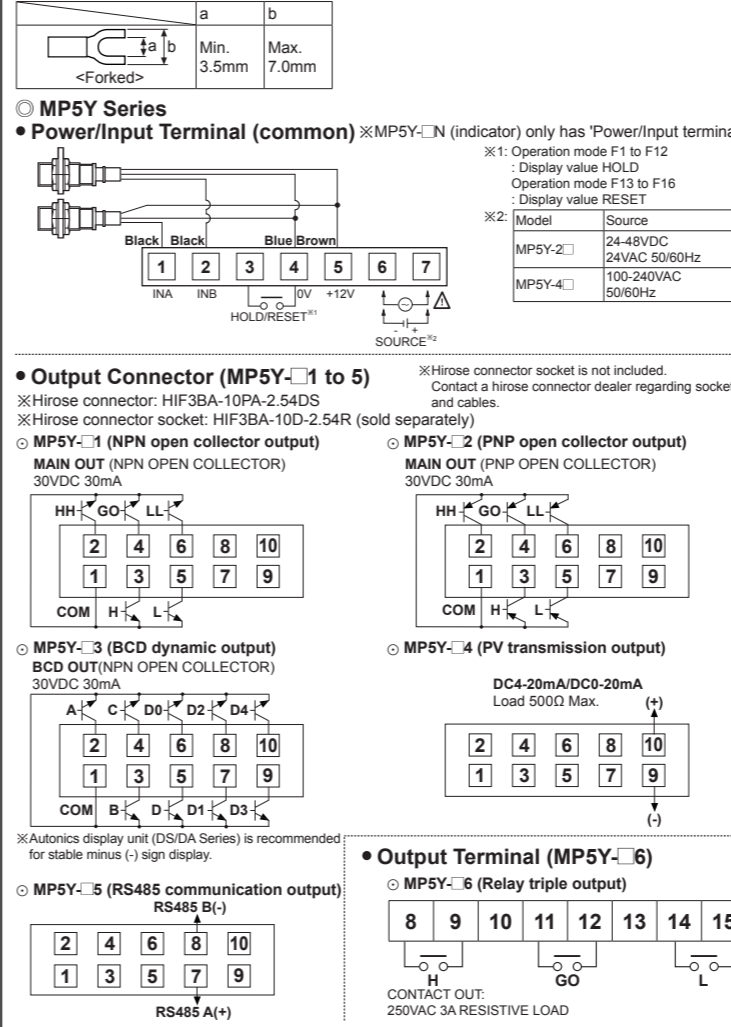

MP5S Series

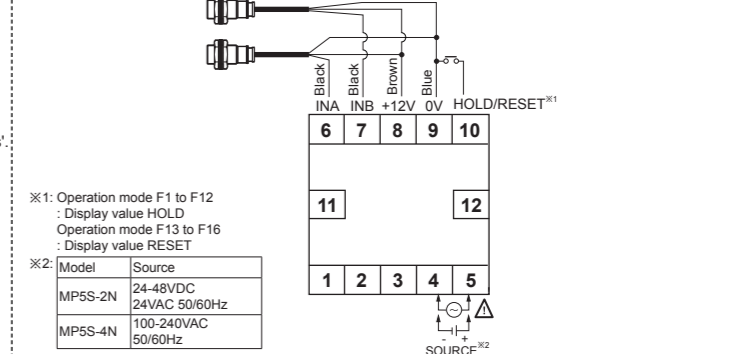

MP5W Series

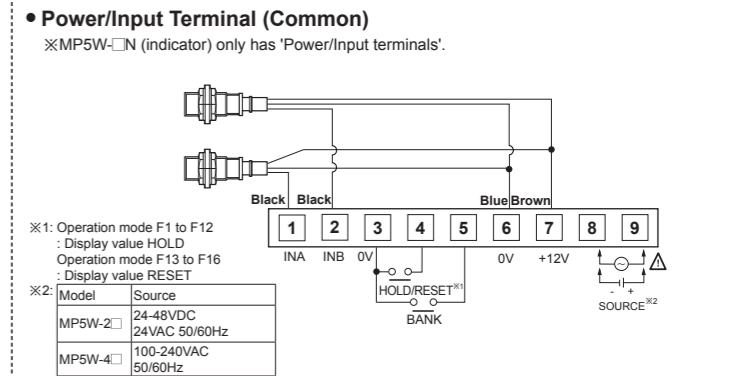

Output Terminal (MP5W-□A/1)

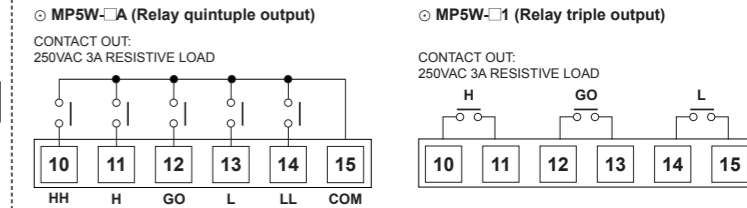

Output Connector (MP5W-□2/4/5/8/9)

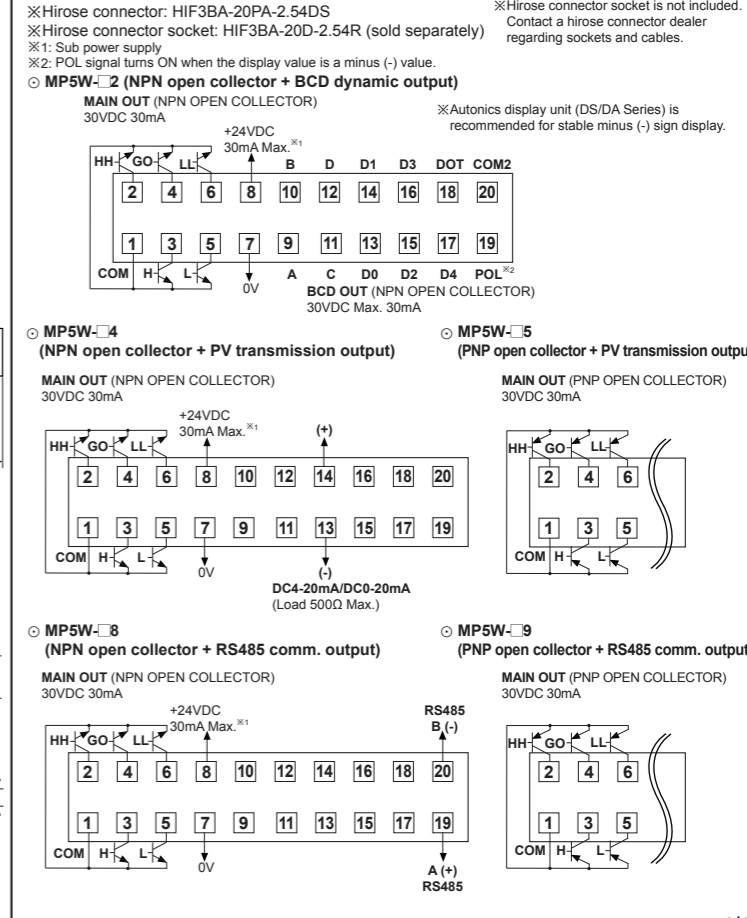

Input/Output Specifications

1. Input Specifications

- Standard duty ratio of input signal is 1:1.
- (1) Solid state input
Input frequency: Max. 50kHz (ON/OFF pulse width: min. 10μs of each)
※T: single cycle of input signal
- (2) Solid state input 2
Input frequency: Max. 5kHz (ON/OFF pulse width: min. 100μs of each)
※For F7, F8, F9, F10 operation mode, max. 1kHz (ON/OFF pulse width: min. 500μs of each)
- (3) Contact input
Input frequency: Max. 45Hz (when each ON/OFF pulse width is over 11ms)
Contact specifications: 12VDC, stable switching of load current as small as 5mA

2. Input type [n-R, i-n-b]

MP5 allows selection between NPN input (solid state/contact) or PNP input (solid state/contact).

(1) NPN input type

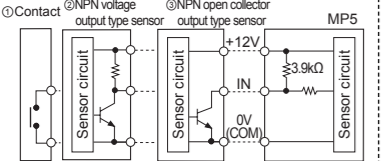

(2) PNP input type

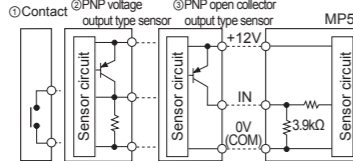

3. Output Specifications

1. Relay output

- Output: Comparative or alarm output (refer to "Output mode")
- Output type: Relay
- Contact capacity: 250VAC 3A resistive load
- Life cycle: [Mechanical] min. 10,000,000 operations (switching frequency 180 operations/min)
[Electrical] min. 100,000 operations (3A 250VAC, 30VDC resistive load) (switching frequency 20 operations/min)

2. Transistor output

- Output: Comparative output or alarm output (refer to "Output mode")
- Output type: NPN/PNP open collector
- Rated load voltage: 30VDC
- Max. load current: 30mA

3. BCD dynamic output(negative logic)

- Output: present value
- Output signal: BCD data (A, B, C, D, DOT) ← A: lowest bit, DOT: highest bit
Digit data (D0, D1, D2, D3, D4) ← D0: lowest digit, D4: highest digit
- Output type: NPN open collector
- Rated load voltage: 30VDC
- Max. load current: 30mA
- Dynamic COM cycle (T) = 40ms
- E.g.) To display value = 125.89 by BCD dynamic output

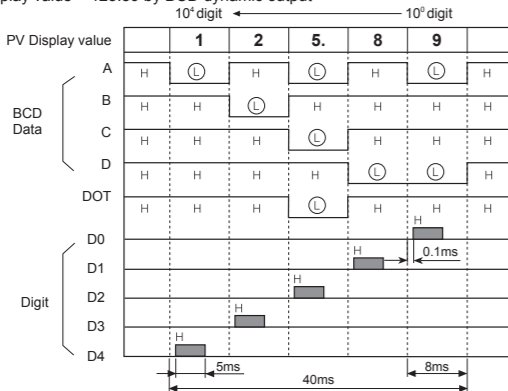

4. PV transmission output

- Application: transmit measured value
- Function: transmit measured value within setting range of high-limit output [F5-H] to low-limit output [F5-L] after conversion into DC4-20mA or DC0-20mA current.
- Output range of high/low-limit
High-limit [F5-H] range: From min. value to max. value within measurement range
Low-limit [F5-L] range: From min. value to max. value within measurement range ($[F5-H] \geq [F5-L] + 1$)

(1) DC4-20mA transmission output

- Transmit measured value within setting range of high-limit output [F5-H] to low-limit output [F5-L] after conversion into DC4-20mA current.
- Resistive load: Max. 500Ω
- Resolution: 8000 divisions

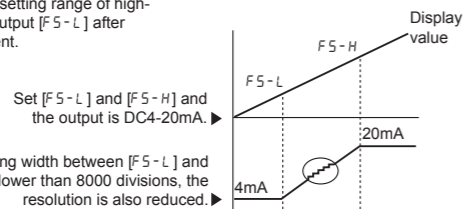

(2) DC0-20mA transmission output

- Transmit measured value within setting range of high-limit output [F5-H] to low-limit output [F5-L] after conversion into DC0-20mA current.
- Resistive load: Max. 500Ω
- Resolution: 10,000 divisions

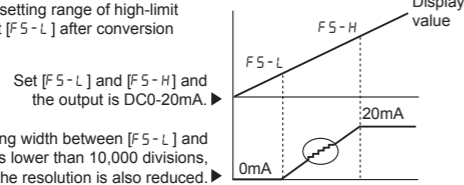

5. RS485 communication output

Comm. protocol	Modbus RTU	Comm. speed	2400, 4800, 9600 (default), 19200, 38400 bps
Connection method	RS485	Comm. response time	5 to 99ms (default: 20ms)
Application standard	Compliance with EIA RS485	Start bit	1-bit (fixed)
Max. connections	31 units (address: 1 to 99)	Data bit	8-bit (fixed)
Synchronization method	Asynchronous	Parity bit	None (default), Even, Odd
Comm. method	Two-wire half duplex	Stop bit	1-bit, 2-bit (default)
Comm. distance	Max. 800m		

※For more information about RS485 communication output specifications, refer to "RS485 communication output".

Unit Description

MP5S

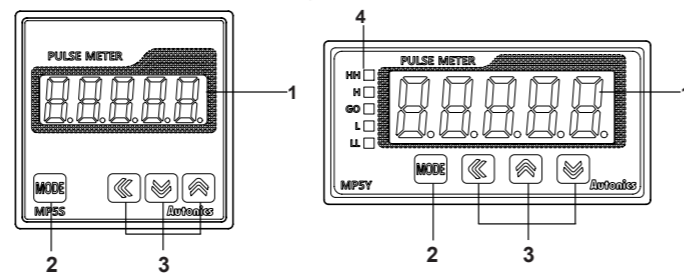

MP5Y

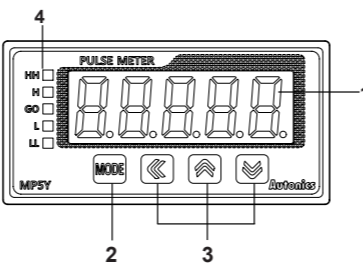

MP5W

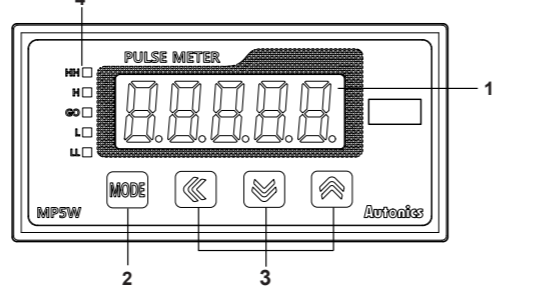

1: Display component

Displays current value in RUN mode. Alternately displays setting parameters and corresponding value in SETTING mode.

2: MODE key

In RUN mode, press the key once to check max./min. value. In RUN mode, hold the key for over 2 sec to enter parameter groups.

3: ←, →, Auto key

Select parameter groups, and select or setting values in the corresponding parameters.

4: Output status indicator

Parameter Groups

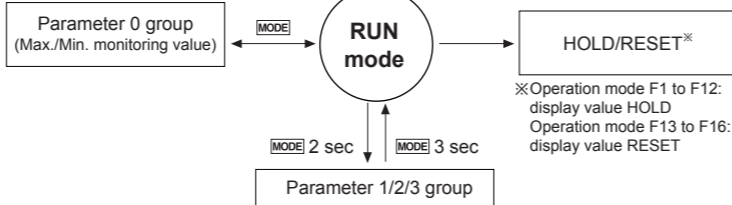

- Press the ←, →, Auto keys to select or set the desired value.
- Press the MODE key once after changing the setting value, to save the setting value and move to the next parameter.
- Hold the MODE key for 1.5 sec at any parameters to return to the select parameter group mode.
- Hold the MODE key for 3 sec to save the setting value and return to RUN mode after changing the setting value.
- If there is no key input for 60 sec while setting the parameters, the new settings are ignored, and the unit will return to RUN mode with previous settings.
- The dotted line parameters may not appear depending on output specifications or other parameter settings. Please refer to "Operation mode by parameter group".
- ※1: Each parameter and corresponding setting value will flash alternately every 0.5 sec.

Parameter 0 Group

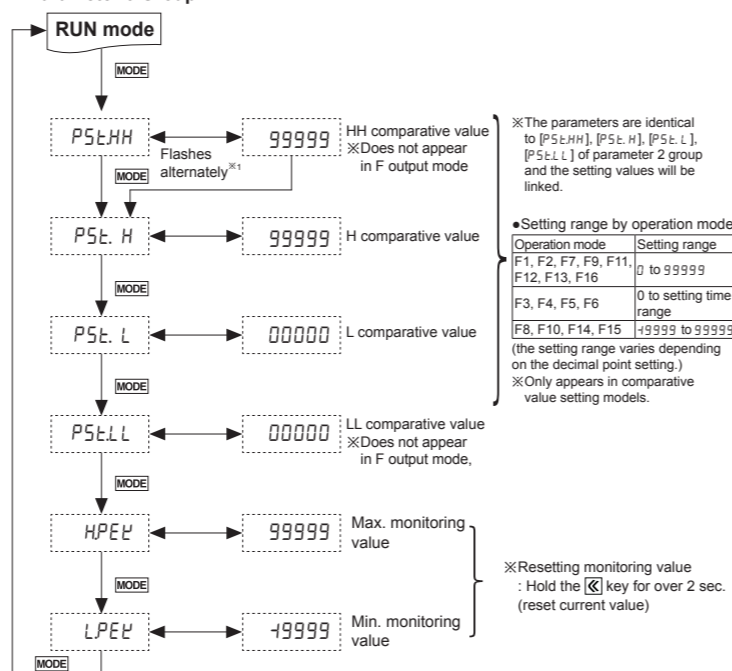

Parameter 1 Group

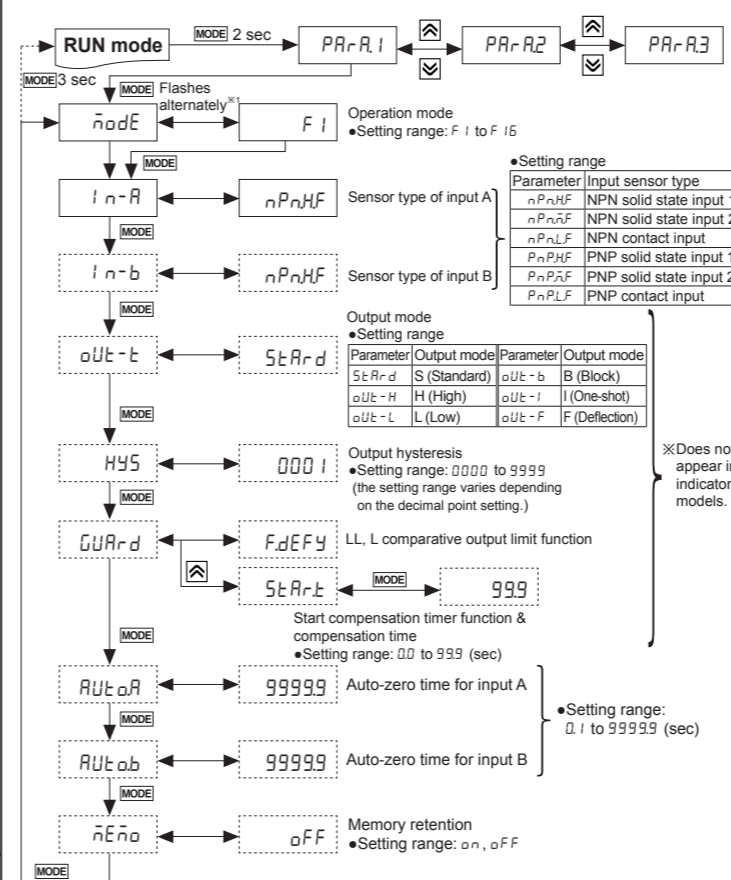

Parameter 2 Group

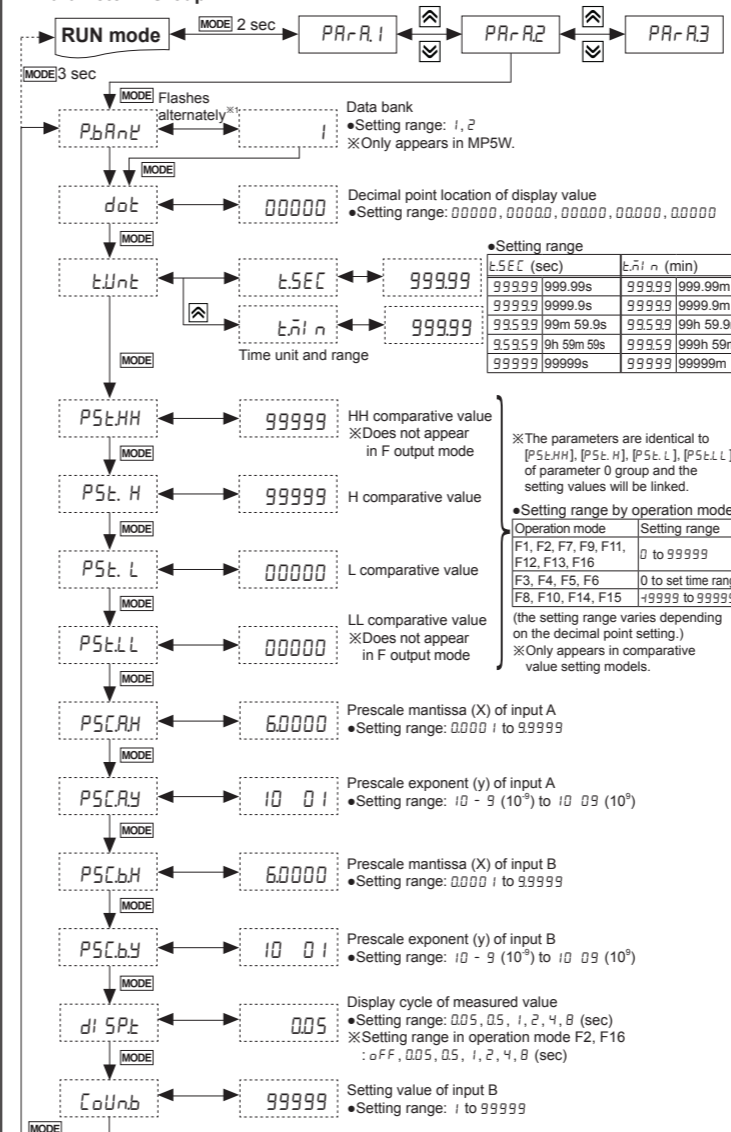

Parameter 3 Group

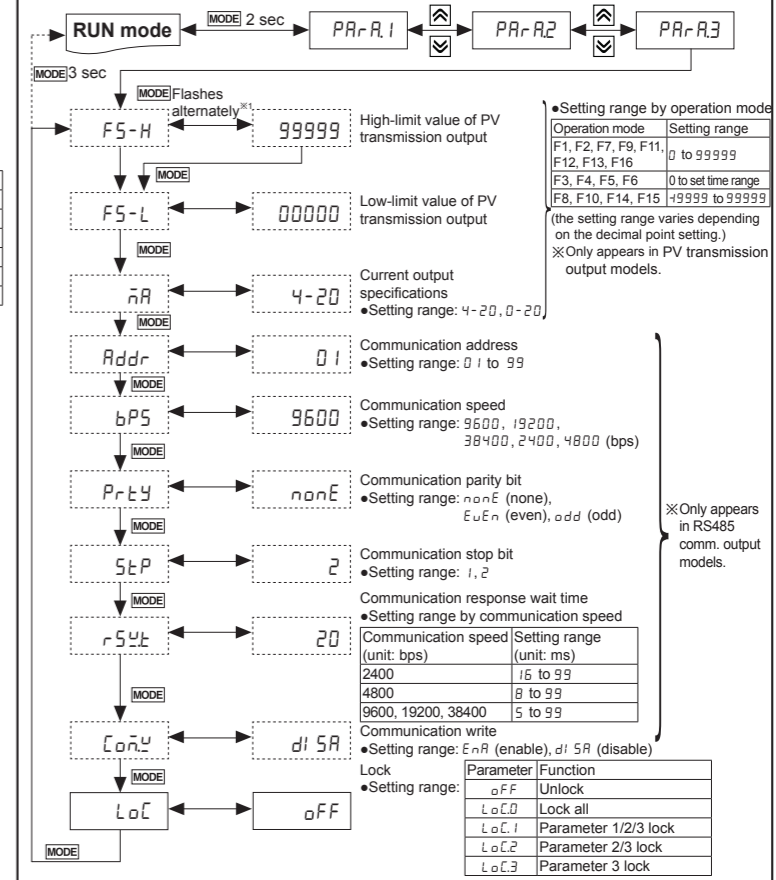

Operation Mode By Parameter Groups

Parameter	Operation mode	F1	F2	F3	F4	F5	F6	F7	F8	F9	F10	F11	F12	F13	F14	F15	F16	
0 group	PSt.HH ^{※1}																	
	PSt.H ^{※2}																	
	PSt.L ^{※2}																	
	PSt.LL ^{※1}																	
	HPEL																	
1 group	i-n-A																	
	i-n-b	X		X	X	X											X ^{※3}	
	oUt-t																X ^{※4}	
	HYS		X	X	X	X	X										X	
	GUAR-d															X	X	
	AUt-a	X	X	X	X	X	X										X	
	AUt-ab	X	X	X	X	X	X										X	
	nEn	X	X	X	X	X	X	X	X	X	X	X	X	X	X	X	X	
	PbaRt																	
	dot		X	X	X	X	X	X	X	X	X	X	X	X	X	X	X	
2 group	PSt.HH ^{※1}																	
	PSt.H ^{※2}																	
	PSt.LL ^{※2}																	
	PSt.L ^{※1}																	
	PSCAH		X	X	X	X	X											
3 group	F5-H																	
	F5-L																	
	nA																	
	Addr																	
	bPS																	
	PrtY																	
	LoC																	

- ※1: Only appears in only for quintuple output models.
 - ※2: Only appears in triple, quintuple output models.
 - ※3: The settings for i-n-b and i-n-A are applied.
 - ※4: F output mode[oUt-t-F] cannot be set.
 - ※5: (■) setting range: oFF, 0.05, 0.5, 1, 2, 4, 8
- Monitoring delay function by output mode
- | Output mode | S mode | H mode | L mode | B mode | I mode | F mode |
|--------------------------|--------|--------|--------|--------|--------|--------|
| Parameter | StAr-d | oUt-t | oUt-l | oUt-b | oUt-i | oUt-F |
| Comparative output limit | | X | X | | X | |
| Start compensation timer | | | | | | |

Operation Modes [n o d E]

- Select operation mode from operation mode[n o d E] of parameter 1 group.
- MP5 has 16 operation modes.

F1 Mode: Frequency/Revolutions/Speed

Measures the frequency of input A and displays the calculated frequency, revolutions, and speed.

- Frequency(Hz) = $f \times \alpha$ ($\alpha=1[\text{sec}]$)
 - Revolutions(rpm) = $f \times \alpha$ ($\alpha=60[\text{sec}]$)
 - Speed(m/min) = $f \times \alpha$ ($\alpha=60L[\text{sec}]$)
- ※L: travel distance of conveyor belt of 1 cycle[m]
 ※ α : prescale value
 For multiple objects, $\alpha = \frac{60L}{N}$

Display value and display unit

Display value	Display unit	α (prescale value)
Frequency	Hz	1
	kHz	0.001
Revolutions	rps	1
	rpm(default)	60
	mm/sec	1,000L
	cm/sec	100L
Speed	m/sec	1L
	m/min	60L
	km/hour	3.6L

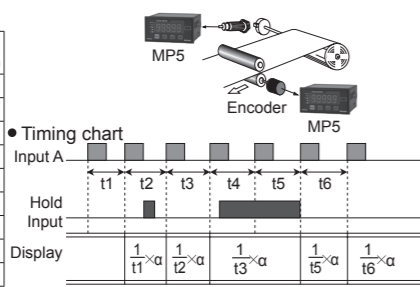

F2 Mode: Passing Speed

Displays the passing speed between input A ON and input B ON.

$$\text{Passing speed}(V) = f \times \alpha (\alpha=L[m])$$

※f: reciprocal of time [sec] between input A(sensor) ON and input B(sensor) ON.
 L: distance between input A(sensor) and input B(sensor) [m]
 ※ α : prescale value

Display value and display unit

Display value	Display unit	α (prescale value)
Passing speed	mm/sec	1,000L
	cm/sec	100L
	m/sec (default)	1L
	m/min	60L
	km/hour	3.6L

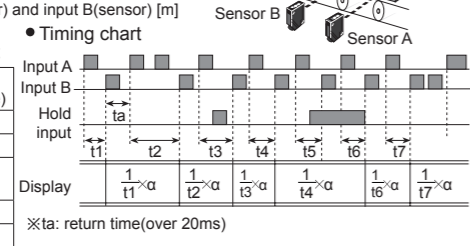

F3 Mode: Cycle

Displays the measured time from input A ON to the next ON.

$$\text{Cycle}(T) = t$$

※t: measurement time[sec]

Display value and display unit [t:Unit] of parameter 2)

Display value	Display unit	MIN
Cycle	SEC	999.99s
	MIN	999.99m
	SEC	9999.9s
	MIN	9999.9m
	SEC	99m 59.9s
	MIN	99h 59.9m
	SEC	9h 59m 59s
	MIN	999h 59m
	SEC	99999s
	MIN	99999m

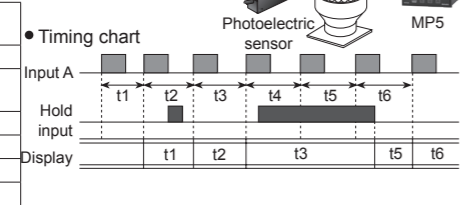

F4 Mode: Passing Time

Measure the time from input A ON to the next ON, and displays the passing time of the arbitrary distance.

$$\text{Passing time}[\text{sec}] = t \times \alpha$$

($\alpha = \frac{L[m]}{\text{Distance advanced in 1 pulse cycle}[m]}$)

※t: measured time[sec], L: arbitrary distance[m]
 ※ α : prescale value

Display value and display unit [t:Unit] of parameter 2)

Display value	Display unit	MIN
Passing time	SEC	999.99s
	MIN	999.99m
	SEC	9999.9s
	MIN	9999.9m
	SEC	99m 59.9s
	MIN	99h 59.9m
	SEC	9h 59m 59s
	MIN	999h 59m
	SEC	99999s
	MIN	99999m

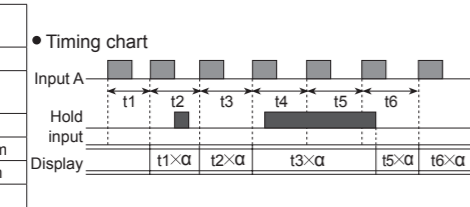

F5 Mode: Time Interval

Displays measured time of input A ON.

$$\text{Time interval}(T) = t$$

※t: measured time of input A ON [sec]

Display value and display unit [t:Unit] of parameter 2)

Display value	Display unit	MIN
Time interval	SEC	999.99s
	MIN	999.99m
	SEC	9999.9s
	MIN	9999.9m
	SEC	99m 59.9s
	MIN	99h 59.9m
	SEC	9h 59m 59s
	MIN	999h 59m
	SEC	99999s
	MIN	99999m

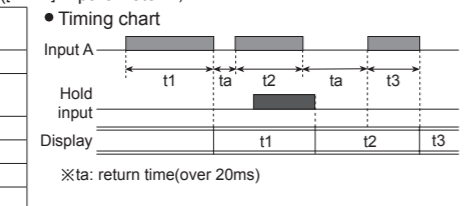

F6 Mode: Time Differential

Displays measured time from Input A ON to Input B ON.

$$\text{Time difference}(T) = t(t_a \text{ to } t_b)$$

※t(ta to tb): measured time from input A ON to input B ON[sec]

Display value and display unit [t:Unit] of parameter 2)

Display value	Display unit	MIN
Time differential	SEC	999.99s
	MIN	999.99m
	SEC	9999.9s
	MIN	9999.9m
	SEC	99m 59.9s
	MIN	99h 59.9m
	SEC	9h 59m 59s
	MIN	999h 59m
	SEC	99999s
	MIN	99999m

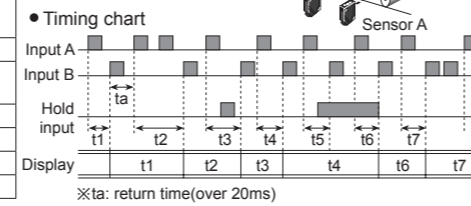

F7 Mode: Absolute Ratio

Measures and displays relative speed, amount, speed, etc. of input B against input A in percentage(%).

$$\text{Absolute ratio} = \left(\frac{\text{Input B} / \text{Input A}}{\text{Frequency of input A}[\text{Hz}] \times \alpha_a} \times 100\% \right)$$

$$\text{Absolute ratio} = \left(\frac{\text{Frequency of input B}[\text{Hz}] \times \alpha_b}{\text{Frequency of input A}[\text{Hz}] \times \alpha_a} \times 100\% \right)$$

※ α_a : prescale value of input A, α_b : prescale value of input B

Display value and display unit

Display value	Display unit
Absolute ratio	%

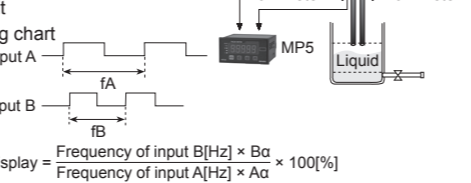

F8 Mode: Error Ratio

Measures and displays the relative rate of input B against the reference value of input A in percentage(%).

$$\text{Error ratio} = \left(\frac{\text{Input B} - \text{Input A}}{\text{Input A}} \times 100\% \right)$$

$$\text{Error ratio} = \left(\frac{\text{Frequency of input B}[\text{Hz}] \times \alpha_b - \text{Frequency of input A}[\text{Hz}] \times \alpha_a}{\text{Frequency of input A}[\text{Hz}] \times \alpha_a} \times 100\% \right)$$

※ α_a : prescale value of input A, α_b : prescale value of input B

Display value and display unit

Display value	Display unit
Error ratio	%

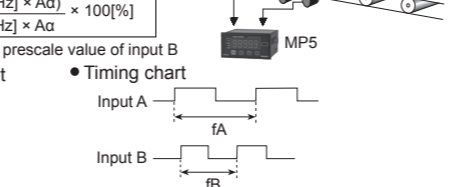

F9 Mode: Density

Measures and displays the density ratio (%) of input B against the total sum of input A and input B.

$$\text{Density} = \left(\frac{\text{Input B}}{\text{Input A} + \text{Input B}} \times 100\% \right)$$

$$\text{Density} = \left(\frac{\text{Frequency of input B}[\text{Hz}] \times \alpha_b}{\text{Frequency of input A}[\text{Hz}] \times \alpha_a + \text{Frequency of input B}[\text{Hz}] \times \alpha_b} \times 100\% \right)$$

※ α_a : prescale value of input A, α_b : prescale value of input B

Display value and display unit

Display value	Display unit
Density	%

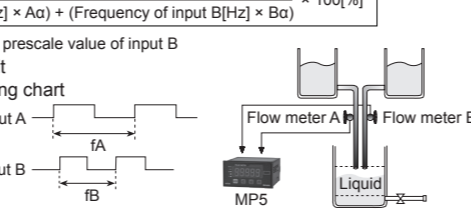

F10 Mode: Error

Measures and displays the error of input B against reference value of input A.

$$\text{Error} = \text{Input B} - \text{Input A}$$

$$\text{Error} = \left(\text{Frequency of input B}[\text{Hz}] \times \alpha_b - \left(\text{Frequency of input A}[\text{Hz}] \times \alpha_a \right) \right)$$

※ α_a : prescale value of input A, α_b : prescale value of input B

Display value and display unit

Display value	Display unit
Error	END User setting

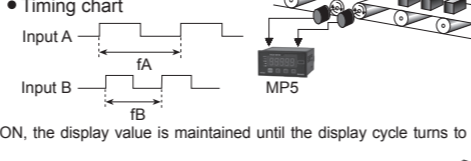

F11 Mode: Length Measurement 1

Measure and display the number of input A pulses during input B ON.

$$\text{Length measurement} = P \times \alpha$$

※P: number of input A pulses, α : prescale value

Display value and display unit

Display value	Display unit
Length measurement	Quantity (default)
	mm
	cm
	m

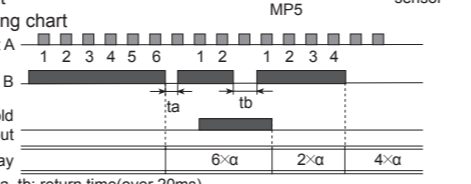

F12 Mode: Interval

Measures and displays the number of input A pulses from input B ON to the next ON.

$$\text{Interval} = P \times \alpha$$

※P: number of input A pulses, α : prescale value

Display value and display unit

Display value	Display unit
Interval	Quantity (default)
	mm
	cm
	m



F13 Mode: Accumulation

Measures and displays the counted value of input A pulses.

$$\text{Accumulation} = P \times \alpha$$

※P: number of input A pulses, α : prescale value

Operation

- Counts the number of input A pulses
- Input B is an enable input signal.

During ON, the quantity and display value of input A will be held, and during OFF input A will be re-counted.

③ When RESET input is ON, the integrated counted value will be reset to "0"

Display value and display unit

Display value	Display unit
Accumulation	Quantity

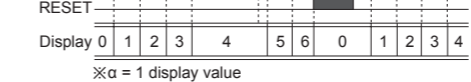

F14 Mode: Addition/Subtraction-Individual Input

Displays the counted value from added input A pulses and subtracted input B pulses. When there are two inputs simultaneously, it will not count.

$$\text{Addition/Subtraction(individual input)} = \text{Input A} \times \alpha - \text{Input B} \times \beta$$

※ α : prescale value of input A, β : prescale value of input B

Display value and display unit

Display value	Display unit
Addition/Subtraction (individual input)	Quantity

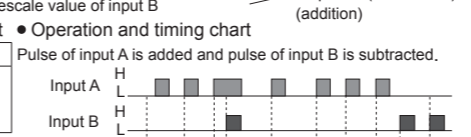

F15 Mode: Addition/Subtraction-Phase Difference Input

When input A is Low, counting is added to the low of input B.

When input A is High, counting is subtracted from the high of input B.

Addition/Subtraction(phase difference) = Detects position and speed using A and B phases of encoder outputs as input.

Display value and display unit

Display value	Display unit
Addition/Subtraction (phase difference input)	Quantity

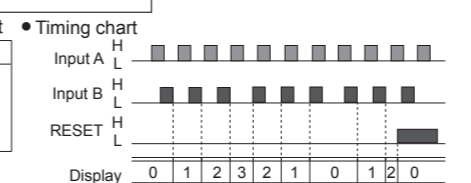

F16 Mode: Length Measurement 2

Measures and displays the number of pulses from input A until the value of input B reaches the setting value.

$$\text{Length measurement 2} = P \times \alpha (\text{until the setting value of input B})$$

※P: number of input A pulses, α : prescale value

Display value and display unit

Display value	Display unit
Length measurement 2	Quantity

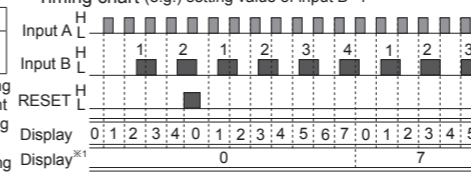

Output Modes [o Ut - t]

- MP5 Series supports 6 output modes. (There is no output mode in indicator models).
- Requirement for setting comparative value: (B output mode) LL<L<H<HH, (F output mode) L<H, (other output modes) individual output operation regardless of size or order of set comparative values.

S (Standard) Output Mode [5 t R r d]

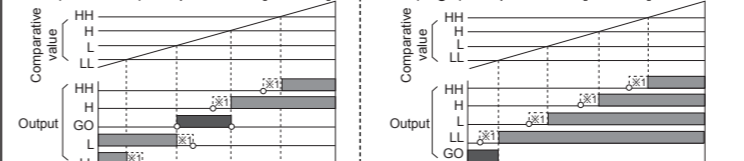

HH output : Display value \geq Comparative setting value HH
 H output : Display value \geq Comparative setting value H
 L output : Display value \leq Comparative setting value L
 LL output : Display value \leq Comparative setting value LL
 ※GO output ON when there are no HH, H, L, LL outputs

H (High) Output Mode [o Ut - H]

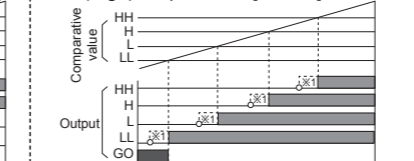

HH output : Display value \geq Comparative setting value HH
 H output : Display value \geq Comparative setting value H
 L output : Display value \geq Comparative setting value L
 LL output : Display value \geq Comparative setting value LL
 ※GO output ON when there are no HH, H, L, LL outputs

L (Low) Output Mode [o Ut - L]

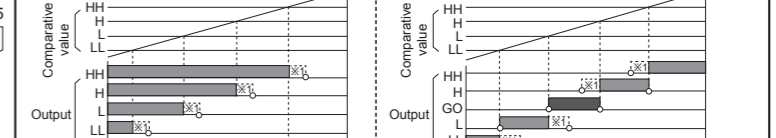

HH output : Display value \leq Comparative setting value HH
 H output : Display value \leq Comparative setting value H
 L output : Display value \leq Comparative setting value L
 LL output : Display value \leq Comparative setting value LL
 ※GO output ON when there are no HH, H, L, LL outputs

B (Block) Output Mode [o Ut - b]

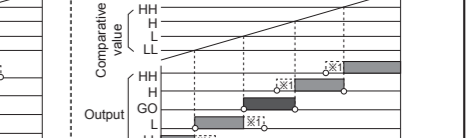

HH output : Display value \geq Comparative setting value HH
 H output : Display value \geq Comparative setting value H
 L output : Display value \geq Comparative setting value L
 LL output : Display value \geq Comparative setting value LL
 ※GO output ON when there are no HH, H, L, LL outputs

I (One-shot) Output Mode [o Ut - I]

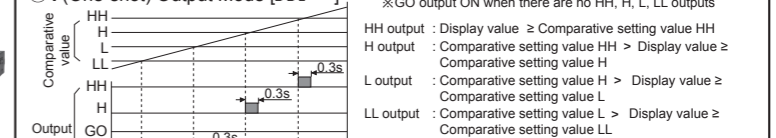

HH output : Display value \geq Comparative setting value HH
 H output : Display value \geq Comparative setting value H
 L output : Display value \geq Comparative setting value L
 LL output : Display value \geq Comparative setting value LL
 ※No GO output
 ※One-shot output time is fixed at 0.3 sec.
 ※No hysteresis

F (Deflection) Output Mode [o Ut - F]

Transmits outputs when the saved setting value exceeds H deviation or L deviation.

● Saving setting value: press the MODE+H key to save as setting value.

● Checking setting value: press the H key to check the setting value.

● Setting deviation: Sets H deviation [P5t. H], and L deviation [P5t. L] of parameter group 0.2 with the setting value as reference. (The set deviation value is saved during Power OFF until it is re-set.)

● Deviation setting range: 0.0001 to 99999(the setting range varies depending on the decimal point [o Ut] setting.)

※2: When selecting initial comparative output limit function, it does not transmit outputs.

※3: The graph is assuming that there is a saved setting value prior to the setting value save point. The actual output position may be different.

RS485 Communication Output

• Applicable for models with RS485 communication output through sub output (MP5Y-□5, MP5W-□8/9). Please refer to 'Ordering information'.

1. Communication Specifications

Comm. protocol	Modbus RTU	Comm. speed	2400, 4800, 9600 (default), 19200, 38400 bps
Connection method	RS485	Comm. response time	5 to 99ms (default: 20ms)
Application standard	Compliance with EIA RS485	Start bit	1-bit (fixed)
Max. connections	31 units (address: 1 to 99)	Data bit	8-bit (fixed)
Synchronization method	Asynchronous	Parity bit	None (default), Even, Odd
Comm. method	Two-wire half duplex	Stop bit	1-bit, 2-bit (default)
Comm. distance	Max. 800m		

2. System Configuration

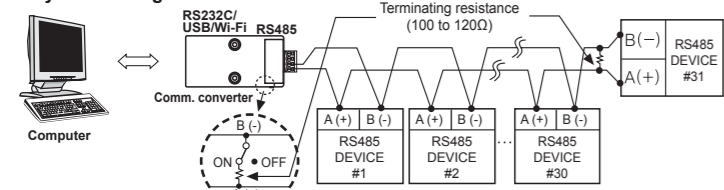

※It is recommended to use Autonics communication converter: SCM-WF48 (Wi-Fi to RS485-USB wireless communication converter, sold separately), SCM-US481 (USB to RS485 converter, sold separately), SCM-381 (RS232C to RS485 converter, sold separately). Please use twisted pair wire, which is suitable for RS485 communication, for SCM-WF48, SCM-US481 and SCM-381.

3. Communication Control Sequence

1. Communication sequence follows Modbus RTU protocol.
2. Communication with the host system can be established after 1 sec (1,000ms) of supplying power.
3. The initial transmission authority is held by the host device (PC). When the host device transmits a request, the MP5W/Y Series sends a response.

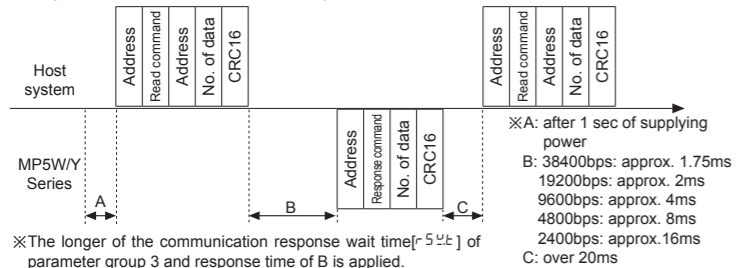

※The longer of the communication response wait time [5 sec] of parameter group 3 and response time of B is applied.

4. Cautions For Communication

1. Twisted pair wire (AWG24) is recommended for RS485 communication. When not using twisted pair wires, please make sure that A (+) and B (-) cable lengths are equal.
2. After connecting the communication cable, terminating resistors (100 to 120Ω) must be attached at both ends.

5. Communication Command And Block Definition

5-1. Read Coil Status (Func 01 H), Read Input Status (Func 02 H)

1) Query (Master)

Slave Address	Function (command)	Starting Address		No. of Points(no. of data)		Error Check(CRC 16)	
		High	Low	High	Low	Low	High
1Byte	1Byte	1Byte	1Byte	1Byte	1Byte	1Byte	1Byte

2) Response (Slave)

Slave Address	Function (command)	Byte Count (no. of data byte)	Data(low)		Data(high)		Error Check(CRC 16)	
			High	Low	High	Low	Low	High
1Byte	1Byte	1Byte	1Byte	1Byte	1Byte	1Byte	1Byte	

5-2. Read Holding Registers(Func 03 H), Read Input Registers (Func 04 H)

1) Query (Master)

Slave Address	Function (command)	Starting Address		No. of Points(no. of data)		Error Check(CRC 16)	
		High	Low	High	Low	Low	High
1Byte	1Byte	1Byte	1Byte	1Byte	1Byte	1Byte	1Byte

2) Response (Slave)

Slave Address	Function (command)	Byte Count (no. of data byte)	Data		Data		Error Check(CRC 16)	
			High	Low	High	Low	Low	High
1Byte	1Byte	1Byte	1Byte	1Byte	1Byte	1Byte	1Byte	

5-3. Force Single Coil (Func 05 H)

1) Query (Master)

Slave Address	Function (command)	Coil Address		Force Data		Error Check(CRC 16)	
		High	Low	High	Low	Low	High
1Byte	1Byte	1Byte	1Byte	1Byte	1Byte	1Byte	1Byte

2) Response (Slave)

Slave Address (address)	Function (command)	Coil Address		Force Data		Error Check(CRC 16)	
		High	Low	High	Low	Low	High
1Byte	1Byte	1Byte	1Byte	1Byte	1Byte	1Byte	1Byte

5-4. Preset Single Register (Func 06 H)

1) Query (Master)

Slave Address	Function (command)	Register Address		Preset Data		Error Check(CRC 16)	
		High	Low	High	Low	Low	High
1Byte	1Byte	1Byte	1Byte	1Byte	1Byte	1Byte	1Byte

2) Response (Slave)

Slave Address	Function (command)	Register Address		Preset Data		Error Check(CRC 16)	
		High	Low	High	Low	Low	High
1Byte	1Byte	1Byte	1Byte	1Byte	1Byte	1Byte	1Byte

5-5. Preset Multiple Registers (Func 10 H)

1) Query (Master)

Slave Address	Function (command)	Starting Address		No. of Register		Data		Data		Error Check (CRC 16)	
		High	Low	High	Low	High	Low	High	Low	High	
1Byte	1Byte	1Byte	1Byte	1Byte	1Byte	1Byte	1Byte	1Byte	1Byte	1Byte	1Byte

2) Response (Slave)

Slave Address	Function (command)	Starting Address		No. of Register		Error Check(CRC 16)	
		High	Low	High	Low	Low	High
1Byte	1Byte	1Byte	1Byte	1Byte	1Byte	1Byte	1Byte

5-6. Exception Response-Error Code(exception processing)

Slave Address	Function (command) +80H	Exception code	Error Check(CRC 16)	
			Low	High
1Byte	1Byte	1Byte	1Byte	1Byte

• When a communication error occurs, the highest bit from the received command (function) is set (1), a response command is sent, and the corresponding exception code is transmitted.

- (1) ILLEGAL FUNCTION(Exception Code: 01 H)
: Unsupported command
- (2) ILLEGAL DATA ADDRESS(Exception Code: 02 H)
: The requested start address does not match the transmission address of the device.
- (3) ILLEGAL DATA VALUE(Exception Code: 03 H)
: The number of requested data does not match the transmission number of the device.
- (4) SLAVE DEVICE FAILURE(Exception Code: 04 H)
: The requested command cannot be processed properly.(CRC)

6. Address Mapping Table

6-1. Read Coil Status(Func 01) / Force Single Coil(Func 05)

No.(Address)	Func	R/W	Parameter	Description	Setting range	Note
000001(0000)	01	R/W	HH	HH comparative output	0: OFF / 1: ON	Comparative output LED
000002(0001)	01	R/W	H	H comparative output	0: OFF / 1: ON	
000003(0002)	01	R/W	GO	GO comparative output	0: OFF / 1: ON	
000004(0003)	01	R/W	L	L comparative output	0: OFF / 1: ON	
000005(0004)	01	R/W	LL	LL comparative output	0: OFF / 1: ON	
000006(0005)	01	R/W			0: OFF / 1: ON	
000007(0006)	01	R/W			0: OFF / 1: ON	
000008 to 000050	01	R/W			0: OFF / 1: ON	

6-2. Read Input Status(Func 02)

No.(Address)	Func	R/W	Parameter	Description	Setting range	Note
100001(0000)	02	R	RESET(HOLD)	External input variables	RESET input status	
100002(0001)	02	R	BANK		BANK input status	
100003(0002)	02	R			0: OFF / 1: ON	
100004(0003)	02	R			0: OFF / 1: ON	
100005(0004)	02	R			0: OFF / 1: ON	
100006(0005)	02	R			0: OFF / 1: ON	
100007(0006)	02	R			0: OFF / 1: ON	
100008(0007)	02	R			0: OFF / 1: ON	
100009(0008)	02	R			0: OFF / 1: ON	
100010(0009)	02	R			0: OFF / 1: ON	
100011(000A)	02	R			0: OFF / 1: ON	
100012 to 100050	02	R			0: OFF / 1: ON	

6-3. Read Input Registers(Func 04)

No.(Address)	Func	R/W	Parameter	Description	Factory default	Note
300001 to 300100	04	R		Reserved		
300101(0064)	04	R		Product number H	0	Dedicated model number
300102(0065)	04	R		Product number L	0	
300103(0066)	04	R		Hardware version	1	
300104(0067)	04	R		Software version	1	
300105(0068)	04	R		Model 1	"MP"	
300106(0069)	04	R		Model 2	"S"	
300107(006A)	04	R		Model 3	"□"	
300108(006B)	04	R		Model 4	"□"	
300109(006C)	04	R		Model 5	" "	
300110(006D)	04	R		Model 6	" "	
300111(006E)	04	R		Model 7	" "	
300112(006F)	04	R		Model 8	" "	
300113(0070)	04	R		Model 9	" "	
300114(0071)	04	R		Model 10	" "	
300115(0072)	04	R		Reserved		
300116(0073)	04	R		Reserved		
300117(0074)	04	R		Reserved		
300118(0075)	04	R		Coil status start address	0000	
300119(0076)	04	R		Coil status quantity	0	
300120(0077)	04	R		Input status start address	0000	
300121(0078)	04	R		Input status quantity	0	
300122(0079)	04	R		Holding register start address	0000	
300123(007A)	04	R		Holding register quantity	0	
300124(007B)	04	R		Input register start address	0000	
300125(007C)	04	R		Input register quantity	0	
300126 to 300200	04	R		Reserved		

No.(Address)	Func	R/W	Parameter	Description	Setting range	Factory default
301001(03E8)	04	R	HH H GO L LL	HH LED Display H LED Display GO LED Display L LED Display LL LED Display	0: OFF 1: ON 0: OFF 1: ON 0: OFF 1: ON 0: OFF 1: ON 0: OFF 1: ON	0-bit 1-bit 2-bit 3-bit 4-bit
301002(03E9)	04	R	PV	Measurement value	-19999 to 99999	
301003(03EA)						
301004(03EB)	04	R	DOT		0: 00000 3: 00000 1: 00000 4: 00000 2: 00000	
301005(03EC)	04	R	UNIT		0: 999.99s 5: 999.99m 1: 9999.9s 6: 9999.9m 2: 99m 59.9s 7: 99h 59.9m 3: 9h 59m 59s 8: 999h 59m 4: 99999s 9: 99999m	
301006(03ED)	04	R	MODE	Operation mode	0: F1 to 1: F2 14: F15 2: F3 15: F16	
301007(03EE)	04	R				

6-4. Read Holding Registers(Func 03) / Preset Single Register(Func 06) / Preset Multiple Registers(Func 16)

6-4-1. Comparative value settings and peak value check group

No.(Address)	Func	R/W	Parameter	Description	Setting range	Factory default
400001(0000)	03/16	R/W	P5t.HH	Preset HH	HH comparative value	0 to 99999
400002(0001)	03/16	R/W	P5t.H	Preset H	H comparative value	0 to 99999
400003(0002)	03/16	R/W	P5t.L	Preset L	L comparative value	0 to 99999*1
400004(0003)	03/16	R/W	P5t.LL	Preset LL	LL comparative value	0 to 99999*1
400005(0004)	03/16	R/W	P5t.LL	Preset LL	LL comparative value	0 to 99999*1
400006(0005)	03/16	R/W	P5t.LL	Preset LL	LL comparative value	0 to 99999*1
400007(0006)	03/16	R/W	P5t.LL	Preset LL	LL comparative value	0 to 99999*1
400008(0007)	03/16	R/W	P5t.LL	Preset LL	LL comparative value	0 to 99999*1
400009(0008)	03/16	R/W	HPeL	High peak	High peak value of measured value	99999*2
400010(0009)	03/16	R/W	HPeL	High peak	High peak value of measured value	99999*2
400011(000A)	03/16	R/W	LPeL	Low peak	Low peak value of measured value	-19999*2
400012(000B)	03/16	R/W	LPeL	Low peak	Low peak value of measured value	-19999*2
400013 to 400050	03/06/16	R/W	Reserved			

*1: In operation modes F8, F10, F14, F15, the setting range is -19999 to 99999

*2: Max./Min. measurement value

6-4-2. Parameter 1 Group

No.(Address)	Func	R/W	Parameter	Description	Setting range	Factory default
400051(0032)	03/06/16	R/W	Mode	Input operation mode	0: F1 to 1: F2 14: F15 2: F3 15: F16	0
400052(0033)	03/06/16	R/W	Input A	Sensor type	0: nPnHF 1: nPnLF 2: nPnLF 3: PnPHF 4: PnPHF 5: PnPLF	0
400053(0034)	03/06/16	R/W	Input B	Sensor type	0: 5tPrd 1: 5tL-H 2: 5tL-L 3: 5tL-b 4: 5tL-l 5: 5tL-F	0
400054(0035)	03/06/16	R/W	OutPut type	Output mode	0: 5tPrd 1: 5tL-H 2: 5tL-L 3: 5tL-b 4: 5tL-l 5: 5tL-F	0
400055(0036)	03/06/16	R/W	HYS	Hysteresis	Hysteresis value	1 to 9999
400056(0037)	03/06/16	R/W	Output limit	Output limit function	0: FdEFY 1: 5tPrd	0
400057(0038)	03/06/16	R/W	Start limit value	Start compensation timer value	0.0 to 99.9	0.0
400058(0039)	03/16	R/W	Auto-zero A	Auto-zero time	0.1 to 9999.9	9999.9
400059(003A)	03/16	R/W	Auto-zero B	Auto-zero time	0.1 to 9999.9	9999.9
400060(003B)	03/16	R/W	Auto-zero B	Auto-zero time	0.1 to 9999.9	9999.9
400061(003C)	03/16	R/W	Memory	Memory retention	0: OFF 1: ON	0
400062(003D)	03/06/16	R/W	Reserved			
400063 to 400100	03/06/16	R/W	Reserved			

6-4-3. Parameter 2 Group

No.(Address)	Func	R/W	Parameter	Description	Setting range	Factory default
400101(0064)						